

---

---

**ECMAScript 3.1 Language  
Specification - DRAFT**

---

---



---

# ECMAScript 3.1 Language Specification - **DRAFT**

---



## Brief History

This ECMA Standard is based on several originating technologies, the most well known being JavaScript (Netscape) and JScript (Microsoft). The language was invented by Brendan Eich at Netscape and first appeared in that company's Navigator 2.0 browser. It has appeared in all subsequent browsers from Netscape and in all browsers from Microsoft starting with Internet Explorer 3.0.

The development of this Standard started in November 1996. The first edition of this ECMA Standard was adopted by the ECMA General Assembly of June 1997.

That ECMA Standard was submitted to ISO/IEC JTC 1 for adoption under the fast-track procedure, and approved as international standard ISO/IEC 16262, in April 1998. The ECMA General Assembly of June 1998 approved the second edition of ECMA-262 to keep it fully aligned with ISO/IEC 16262. Changes between the first and the second edition are editorial in nature.

The third edition of the Standard includes powerful regular expressions, better string handling, new control statements, try/catch exception handling, tighter definition of errors, formatting for numeric output and minor changes in anticipation of forthcoming internationalisation facilities and future language growth. [The language documented by the third edition has come to be known as ECMAScript 3 or ES3.](#)

Work on the language is not complete. The technical committee is working on significant enhancements, including mechanisms for scripts to be created and used across the Internet, and tighter coordination with other standards bodies such as groups within the World Wide Web Consortium and the Wireless Application Protocol Forum.

pratapL 5/27/2008 3:45 PM

**Deleted:** current document defines the

pratapL 5/27/2008 3:45 PM

**Deleted:** and

pratapL 5/27/2008 3:47 PM

**Deleted:** This Standard has been adopted as 3rd Edition of ECMA-262 by the ECMA General Assembly in December, 1999.



**Table of contents**

<b>1</b>	<b>Scope</b>	<b>1</b>
<b>2</b>	<b>Conformance</b>	<b>1</b>
<b>3</b>	<b>References</b>	<b>1</b>
<b>4</b>	<b>Overview</b>	<b>1</b>
4.1	Web Scripting	2
4.2	Language Overview	2
4.2.1	Objects	2
4.2.2	Voluntary Usage Language Subsets	3
4.3	Definitions	4
4.3.1	Type	4
4.3.2	Primitive Value	4
4.3.3	Object	4
4.3.4	Constructor	4
4.3.5	Prototype	4
4.3.6	Native Object	4
4.3.7	Built-in Object	4
4.3.8	Host Object	5
4.3.9	Undefined Value	5
4.3.10	Undefined Type	5
4.3.11	Null Value	5
4.3.12	Null Type	5
4.3.13	Boolean Value	5
4.3.14	Boolean Type	5
4.3.15	Boolean Object	5
4.3.16	String Value	5
4.3.17	String Type	5
4.3.18	String Object	5
4.3.19	Number Value	5
4.3.20	Number Type	5
4.3.21	Number Object	5
4.3.22	Infinity	6
4.3.23	NaN	6
4.3.24	Function	6
4.3.25	Property	6
4.3.26	Method	6
4.3.27	Attribute	6
4.3.29	Own Property	6
4.3.28	Inherited Property	6
4.3.29	Built-in Method	6
<b>5</b>	<b>Notational Conventions</b>	<b>7</b>
5.1	Syntactic and Lexical Grammars	7
5.1.1	Context-Free Grammars	7
5.1.2	The Lexical and RegExp Grammars	7

5.1.3	The Numeric String Grammar	7
5.1.4	The Syntactic Grammar	7
5.1.5	Grammar Notation	8
5.2	Algorithm Conventions	10
<b>6.</b>	<b>Source Text</b>	<b>11</b>
<b>7</b>	<b>Lexical Conventions</b>	<b>12</b>
7.1	Unicode Format-Control Characters	12
7.2	White Space	12
7.3	Line Terminators	13
7.4	Comments	14
7.5	Tokens	14
7.5.1	Reserved Words	15
7.5.2	Keywords	15
7.5.3	Future Reserved Words	15
7.6	Identifiers	15
7.7	Punctuators	16
7.8	Literals	17
7.8.1	Null Literals	17
7.8.2	Boolean Literals	17
7.8.3	Numeric Literals	17
7.8.4	String Literals	19
7.8.5	Regular Expression Literals	21
7.9	Automatic Semicolon Insertion	22
7.9.1	Rules of Automatic Semicolon Insertion	23
7.9.2	Examples of Automatic Semicolon Insertion	24
<b>8</b>	<b>Types</b>	<b>25</b>
8.1	The Undefined Type	25
8.2	The Null Type	25
8.3	The Boolean Type	25
8.4	The String Type	25
8.5	The Number Type	26
8.6	The Object Type	27
8.6.1	Property Attributes	27
8.6.2	Internal Properties and Methods	28
8.7	The Reference Type	33
8.7.1	GetValue (V)	34
8.7.2	PutValue (V, W, Throw)	34
8.8	The List Type	34
8.9	The Completion Type	34
8.10	The Property Descriptor and Property Identifier Types	34
8.10.1	IsValidDescriptor ( Desc )	35
8.10.2	IsAccessorDescriptor ( Desc )	35
8.10.3	IsDataDescriptor ( Desc )	35
8.10.4	IsGenericDescriptor ( Desc )	35
8.10.5	FromPropertyDescriptor ( Desc )	35



8.10.6	ToPropertyDescriptor ( DescObj )	36
<b>9</b>	<b>Type Conversion and Testing</b>	<b>37</b>
9.1	ToPrimitive	37
9.2	ToBoolean	37
9.3	ToNumber	37
9.3.1	ToNumber Applied to the String Type	38
9.4	ToInteger	40
9.5	ToInt32: (Signed 32 Bit Integer)	40
9.6	ToUint32: (Unsigned 32 Bit Integer)	41
9.7	ToUint16: (Unsigned 16 Bit Integer)	41
9.8	ToString	42
9.8.1	ToString Applied to the Number Type	42
9.9	ToObject	43
9.10	IsCallable	43
<b>10</b>	<b>Execution Contexts</b>	<b>43</b>
10.1	Definitions	43
10.1.1	Function Objects	43
10.1.2	Types of Executable Code	44
10.1.3	Variable Instantiation	44
10.1.4	Scope Chain and Identifier Resolution	45
10.1.5	Global Object	46
10.1.6	Activation Object	46
10.1.7	This	46
10.1.8	Arguments Object	46
10.2	Entering An Execution Context	47
10.2.1	Global Code	47
10.2.2	Eval Code	47
10.2.3	Function Code	47
<b>11</b>	<b>Expressions</b>	<b>47</b>
11.1	Primary Expressions	47
11.1.1	The <code>this</code> Keyword	48
11.1.2	Identifier Reference	48
11.1.3	Literal Reference	48
11.1.4	Array Initialiser	48
11.1.5	Object Initialiser	49
11.1.6	The Grouping Operator	51
11.2	Left-Hand-Side Expressions	51
11.2.1	Property Accessors	52
11.2.2	The <code>new</code> Operator	52
11.2.3	Function Calls	53
11.2.4	Argument Lists	53
11.2.5	Function Expressions	53
11.3	Postfix Expressions	54
11.3.1	Postfix Increment Operator	54
11.3.2	Postfix Decrement Operator	54

11.4	Unary Operators	54
11.4.1	The <code>delete</code> Operator	54
11.4.2	The <code>void</code> Operator	55
11.4.3	The <code>typeof</code> Operator	55
11.4.4	Prefix Increment Operator	55
11.4.5	Prefix Decrement Operator	56
11.4.6	Unary <code>+</code> Operator	56
11.4.7	Unary <code>-</code> Operator	56
11.4.8	Bitwise NOT Operator ( <code>~</code> )	56
11.4.9	Logical NOT Operator ( <code>!</code> )	56
11.5	Multiplicative Operators	56
11.5.1	Applying the <code>*</code> Operator	57
11.5.2	Applying the <code>/</code> Operator	57
11.5.3	Applying the <code>%</code> Operator	58
11.6	Additive Operators	58
11.6.1	The Addition operator ( <code>+</code> )	58
11.6.2	The Subtraction Operator ( <code>-</code> )	59
11.6.3	Applying the Additive Operators ( <code>+</code> , <code>-</code> ) to Numbers	59
11.7	Bitwise Shift Operators	60
11.7.1	The Left Shift Operator ( <code>&lt;&lt;</code> )	60
11.7.2	The Signed Right Shift Operator ( <code>&gt;&gt;</code> )	60
11.7.3	The Unsigned Right Shift Operator ( <code>&gt;&gt;&gt;</code> )	60
11.8	Relational Operators	60
11.8.1	The Less-than Operator ( <code>&lt;</code> )	61
11.8.2	The Greater-than Operator ( <code>&gt;</code> )	61
11.8.3	The Less-than-or-equal Operator ( <code>&lt;=</code> )	61
11.8.4	The Greater-than-or-equal Operator ( <code>&gt;=</code> )	62
11.8.5	The Abstract Relational Comparison Algorithm	62
11.8.6	The <code>instanceof</code> operator	63
11.8.7	The <code>in</code> operator	63
11.9	Equality Operators	63
11.9.1	The Equals Operator ( <code>==</code> )	63
11.9.2	The Does-not-equals Operator ( <code>!=</code> )	64
11.9.3	The Abstract Equality Comparison Algorithm	64
11.9.4	The Strict Equals Operator ( <code>===</code> )	65
11.9.5	The Strict Does-not-equal Operator ( <code>!==</code> )	65
11.9.6	The Strict Equality Comparison Algorithm	65
11.10	Binary Bitwise Operators	65
11.11	Binary Logical Operators	66
11.12	Conditional Operator ( <code>?:</code> )	67
11.13	Assignment Operators	68
11.13.1	Simple Assignment ( <code>=</code> )	68
11.13.2	Compound Assignment ( <code>op=</code> )	68
11.14	Comma Operator ( <code>,</code> )	69

<b>12</b>	<b>Statements</b>	<b>70</b>
12.1	Block	70
12.1.1	Usage Subset cautious Restrictions	71
12.2	Variable statement	71
12.3	Empty Statement	72
12.4	Expression Statement	72
12.5	The <code>if</code> Statement	73
12.6	Iteration Statements	73
12.6.1	The <code>do-while</code> Statement	73
12.6.2	The <code>while</code> statement	74
12.6.3	The <code>for</code> Statement	74
12.6.4	The <code>for-in</code> Statement	75
12.7	The <code>continue</code> Statement	76
12.8	The <code>break</code> Statement	76
12.9	The <code>return</code> Statement	76
12.10	The <code>with</code> Statement	77
12.10.1	Usage Subset cautious Restrictions	77
12.11	The <code>switch</code> Statement	77
12.12	Labelled Statements	79
12.13	The <code>throw</code> statement	79
12.14	The <code>try</code> statement	80
12.15	Constant statement	81
<b>13</b>	<b>Function Definition</b>	<b>82</b>
13.1	Definitions	83
13.2	Creating Function Objects	83
13.2.1	[[Call]]	83
13.2.2	[[Construct]]	83
<b>14</b>	<b>Program</b>	<b>84</b>
<b>15</b>	<b>Native ECMAScript Objects</b>	<b>86</b>
15.1	The Global Object	86
15.1.1	Value Properties of the Global Object	87
15.1.2	Function Properties of the Global Object	87
15.1.3	URI Handling Function Properties	88
15.1.4	Constructor Properties of the Global Object	93
15.1.5	Other Properties of the Global Object	93
15.2	Object Objects	93
15.2.1	The Object Constructor Called as a Function	93
15.2.2	The Object Constructor	94
15.2.3	Properties of the Object Constructor	94
15.2.4	Properties of the Object Prototype Object	97
15.2.5	Properties of Object Instances	98
15.3	Function Objects	98
15.3.1	The Function Constructor Called as a Function	98
15.3.2	The Function Constructor	98

15.3.3	Properties of the Function Constructor	99
15.3.4	Properties of the Function Prototype Object	99
15.3.5	Properties of Function Instances	100
15.4	Array Objects	101
15.4.1	The Array Constructor Called as a Function	101
15.4.2	The Array Constructor	101
15.4.3	Properties of the Array Constructor	102
15.4.4	Properties of the Array Prototype Object	102
15.4.5	Properties of Array Instances	117
15.5	String Objects	118
15.5.1	The String Constructor Called as a Function	118
15.5.2	The String Constructor	118
15.5.3	Properties of the String Constructor	118
15.5.4	Properties of the String Prototype Object	118
15.5.5	Properties of String Instances	126
15.6	Boolean Objects	127
15.6.1	The Boolean Constructor Called as a Function	127
15.6.2	The Boolean Constructor	127
15.6.3	Properties of the Boolean Constructor	127
15.6.4	Properties of the Boolean Prototype Object	127
15.6.5	Properties of Boolean Instances	128
15.7	Number Objects	128
15.7.1	The Number Constructor Called as a Function	128
15.7.2	The Number Constructor	128
15.7.3	Properties of the Number Constructor	128
15.7.4	Properties of the Number Prototype Object	129
15.7.5	Properties of Number Instances	132
15.8	The Math Object	132
15.8.1	Value Properties of the Math Object	132
15.8.2	Function Properties of the Math Object	133
15.9	Date Objects	138
15.9.1	Overview of Date Objects and Definitions of Internal Operators	138
15.9.2	The Date Constructor Called as a Function	142
15.9.3	The Date Constructor	142
15.9.4	Properties of the Date Constructor	143
15.9.5	Properties of the Date Prototype Object	144
15.9.6	Properties of Date Instances	150
15.10	RegExp (Regular Expression) Objects	151
15.10.1	Patterns	151
15.10.2	Pattern Semantics	153
15.10.3	The RegExp Constructor Called as a Function	164
15.10.4	The RegExp Constructor	164
15.10.5	Properties of the RegExp Constructor	165
15.10.6	Properties of the RegExp Prototype Object	165
15.10.7	Properties of RegExp Instances	166
15.11	Error Objects	167
15.11.1	The Error Constructor Called as a Function	167

15.11.2	The Error Constructor	167
15.11.3	Properties of the Error Constructor	167
15.11.4	Properties of the Error Prototype Object	167
15.11.5	Properties of Error Instances	168
15.11.6	Native Error Types Used in This Standard	168
15.11.7	<i>NativeError</i> Object Structure	168
15.12	JSON	170
15.12.1	parse ( text, reviver )	170
15.12.2	stringify ( value, replacer, space )	170
15.13	Decimal	172
15.13.1	Overview of Decimal Objects and Definitions of Internal Operators	172
15.13.2	The Decimal Constructor Called as a Function	172
15.13.3	The Decimal Constructor	172
15.13.4	Properties of the Decimal constructor	173
15.13.5	Properties of the Decimal Prototype Object	173
15.13.6	Properties of Decimal Instances	178
<b>16</b>	<b>Errors</b>	<b>179</b>
<b>Annex A</b>		<b>180</b>
<b>A.1</b>	<b>Lexical Grammar</b>	<b>180</b>
<b>A.2</b>	<b>Number Conversions</b>	<b>185</b>
<b>A.3</b>	<b>Expressions</b>	<b>186</b>
<b>A.4</b>	<b>Statements</b>	<b>191</b>
<b>A.5</b>	<b>Functions and Programs</b>	<b>193</b>
<b>A.6</b>	<b>Universal Resource Identifier Character Classes</b>	<b>194</b>
<b>A.7</b>	<b>Regular Expressions</b>	<b>194</b>
<b>Annex B</b>		<b>198</b>
<b>Compatibility</b>		<b>198</b>
<b>B.1</b>	<b>Additional Syntax</b>	<b>198</b>
B.1.1	Numeric Literals	198
B.1.2	String Literals	198
<b>B.2</b>	<b>Additional Properties</b>	<b>199</b>
B.2.1	escape (string)	199
B.2.2	unescape (string)	200
B.2.3	String.prototype.substr (start, length)	200
B.2.4	Date.prototype.getYear ( )	201
B.2.5	Date.prototype.setYear (year)	201
B.2.6	Date.prototype.toGMTString ( )	201
<b>Annex C</b>		<b>202</b>

<b>Usage Subsets</b>	<b>202</b>
C.1 The cautious Subset	202
C.1.1 Excluded Features	202
C.1.2 Additional Execution Exceptions	203
<b>Annex D</b>	<b>204</b>
<b>Correction and Clarifications in Edition 3.1 with Possible Compatibility Impact</b>	<b>204</b>
<b>Annex E</b>	<b>205</b>
<b>Additions and Changes in Edition 3.1 which Introduce Incompatibilities with Edition 3.</b>	<b>205</b>

## 1 Scope

This Standard defines the ECMAScript scripting language.

## 2 Conformance

A conforming implementation of ECMAScript must provide and support all the types, values, objects, properties, functions, and program syntax and semantics described in this specification.

A conforming implementation of this International standard shall interpret characters in conformance with the Unicode Standard, Version [3.0](#) or later, and ISO/IEC 10646-1 with either UCS-2 or UTF-16 as the adopted encoding form, implementation level 3. If the adopted ISO/IEC 10646-1 subset is not otherwise specified, it is presumed to be the BMP subset, collection 300. If the adopted encoding form is not otherwise specified, it is presumed to be the UTF-16 encoding form.

A conforming implementation of ECMAScript is permitted to provide additional types, values, objects, properties, and functions beyond those described in this specification. In particular, a conforming implementation of ECMAScript is permitted to provide properties not described in this specification, and values for those properties, for objects that are described in this specification.

A conforming implementation of ECMAScript is permitted to support program and regular expression syntax not described in this specification. In particular, a conforming implementation of ECMAScript is permitted to support program syntax that makes use of the “future reserved words” listed in 7.5.3 of this specification.

## 3 References

ISO/IEC 9899:1996 Programming Languages – C, including amendment 1 and technical corrigenda 1 and 2.

ISO/IEC 10646-1:1993 Information Technology -- Universal Multiple-Octet Coded Character Set (UCS) plus its amendments and corrigenda.

[The Unicode Consortium. The Unicode Standard, Version 3.0, defined by: The Unicode Standard, Version 3.0 \(Boston, MA, Addison-Wesley, 2000. ISBN 0-201-61635-5\).](#)

[Unicode Inc. \(1998\), Unicode Technical Report #15: Unicode Normalization Forms.](#)

ANSI/IEEE Std 754-1985: IEEE Standard for Binary Floating-Point Arithmetic. Institute of Electrical and Electronic Engineers, New York (1985).

## 4 Overview

This section contains a non-normative overview of the ECMAScript language.

ECMAScript is an object-oriented programming language for performing computations and manipulating computational objects within a host environment. ECMAScript as defined here is not intended to be computationally self-sufficient; indeed, there are no provisions in this specification for input of external data or output of computed results. Instead, it is expected that the computational environment of an ECMAScript program will provide not only the objects and other facilities described in this specification but also certain environment-specific *host* objects, whose description and behaviour are beyond the scope of this specification except to indicate that they may provide certain properties that can be accessed and certain functions that can be called from an ECMAScript program.

A *scripting language* is a programming language that is used to manipulate, customise, and automate the facilities of an existing system. In such systems, useful functionality is already available through a user interface, and the scripting language is a mechanism for exposing that functionality to program control. In this way, the existing system is said to provide a host environment of objects and facilities, which completes the capabilities of the scripting language. A scripting language is intended for use by both professional and non-professional programmers. To accommodate non-professional programmers, some aspects of the language [are defined to be tolerant of programmer mistakes. However, such tolerance can easily result in programs containing undiscovered errors that professional programmers would wish to discover and correct. To facilitate such error detection script can be explicitly be declared to use a “cautious” subset of the full ECMAScript language that provides enhanced error detection as well.](#)

ECMAScript was originally designed to be a *Web scripting language*, providing a mechanism to enliven Web pages in browsers and to perform server computation as part of a Web-based client-server architecture.

pratapL 6/10/2008 6:45 PM

Deleted: 2.1

pratapL 6/10/2008 6:46 PM

Deleted: Unicode Inc. (1996), The Unicode Standard, Version 2.0. ISBN: 0-201-48345-9, Addison-Wesley Publishing Co., Menlo Park, California.

pratapL 7/1/2008 2:20 PM

Deleted: Unicode Inc. (1998), Unicode Technical Report #8: The Unicode Standard, Version 2.1. .

pratapL 5/27/2008 3:55 PM

Deleted: may be somewhat less strict

ECMAScript can provide core scripting capabilities for a variety of host environments, and therefore the core scripting language is specified in this document apart from any particular host environment.

Some of the facilities of ECMAScript are similar to those used in other programming languages; in particular Java™ and Self, as described in:

- Gosling, James, Bill Joy and Guy Steele. The Java™ Language Specification. Addison Wesley Publishing Co., 1996.
- Ungar, David, and Smith, Randall B. Self: The Power of Simplicity. OOPSLA '87 Conference Proceedings, pp. 227–241, Orlando, FL, October 1987.
- [R. Kelsey, W. Clinger, and J. Rees \(eds.\), Revised<sup>5</sup> Report on the Algorithmic Language Scheme. Higher-Order and Symbolic Computation, Vol. 11, No. 1, 1998.](#)

#### 4.1 Web Scripting

A web browser provides an ECMAScript host environment for client-side computation including, for instance, objects that represent windows, menus, pop-ups, dialog boxes, text areas, anchors, frames, history, cookies, and input/output. Further, the host environment provides a means to attach scripting code to events such as change of focus, page and image loading, unloading, error and abort, selection, form submission, and mouse actions. Scripting code appears within the HTML and the displayed page is a combination of user interface elements and fixed and computed text and images. The scripting code is reactive to user interaction and there is no need for a main program.

A web server provides a different host environment for server-side computation including objects representing requests, clients, and files; and mechanisms to lock and share data. By using browser-side and server-side scripting together, it is possible to distribute computation between the client and server while providing a customised user interface for a Web-based application.

Each Web browser and server that supports ECMAScript supplies its own host environment, completing the ECMAScript execution environment.

#### 4.2 Language Overview

The following is an informal overview of ECMAScript—not all parts of the language are described. This overview is not part of the standard proper.

ECMAScript is object-based: basic language and host facilities are provided by objects, and an ECMAScript program is a cluster of communicating objects. An ECMAScript *object* is an unordered collection of *properties* each with zero or more *attributes* that determine how each property can be used—for example, when the *Writable* attribute for a property is set to *false*, any attempt by executed ECMAScript code to change the value of the property *fails*. Properties are containers that hold other objects, *primitive values*, or *methods*. A primitive value is a member of one of the following built-in types: **Undefined**, **Null**, **Boolean**, **Number**, and **String**; an object is a member of the remaining built-in type **Object**; and a method is a function associated with an object via a property.

ECMAScript defines a collection of *built-in objects* that round out the definition of ECMAScript entities. These built-in objects include the **Global** object, the **Object** object, the **Function** object, the **Array** object, the **String** object, the **Boolean** object, the **Number** object, the **Math** object, the **Date** object, the **RegExp** object, [the JSON object](#), [the Decimal object](#), and the Error objects **Error**, **EvalError**, **RangeError**, **ReferenceError**, **SyntaxError**, **TypeError** and **URIError**.

ECMAScript also defines a set of built-in *operators*. ECMAScript operators include various unary operations, multiplicative operators, additive operators, bitwise shift operators, relational operators, equality operators, binary bitwise operators, binary logical operators, assignment operators, and the comma operator.

ECMAScript syntax intentionally resembles Java syntax. ECMAScript syntax is relaxed to enable it to serve as an easy-to-use scripting language. For example, a variable is not required to have its type declared nor are types associated with properties, and defined functions are not required to have their declarations appear textually before calls to them.

##### 4.2.1 Objects

ECMAScript does not contain *classes* such as those in C++, Smalltalk, or Java, but rather, supports *constructors* which create objects by executing code that allocates storage for the objects and initialises

pratapL 7/4/2008 10:07 AM  
**Comment [1]:** Lars questions the need for this reference or suggests referring R6RS or IEEE standard instead.

pratapL 5/27/2008 3:56 PM  
**Deleted:** ReadOnly

pratapL 5/27/2008 3:57 PM  
**Deleted:** true

pratapL 5/27/2008 3:57 PM  
**Deleted:** has no effect

pratapL 6/30/2008 3:35 PM  
**Deleted:** that may not be, strictly speaking, functions or methods

pratapL 7/1/2008 2:23 PM  
**Deleted:** proper



all or part of them by assigning initial values to their properties. All constructors are objects, but not all objects are constructors. Each constructor has a property named "prototype" that is used to implement *prototype-based inheritance* and *shared properties*. Objects are created by using constructors in **new** expressions; for example, `new String("A String")` creates a new String object. Invoking a constructor without using **new** has consequences that depend on the constructor. For example, `String("A String")` produces a primitive string, not an object.

ECMAScript supports *prototype-based inheritance*. Every object created by a constructor has an implicit reference (called the *object's prototype*) to the value of its constructor's "prototype" property. Furthermore, a prototype may have a non-null implicit reference to its prototype, and so on; this is called the *prototype chain*. When a reference is made to a property in an object, that reference is to the property of that name in the first object in the prototype chain that contains a property of that name. In other words, first the object mentioned directly is examined for such a property; if that object contains the named property, that is the property to which the reference refers; if that object does not contain the named property, the prototype for that object is examined next; and so on.

In a class-based object-oriented language, in general, state is carried by instances, methods are carried by classes, and inheritance is only of structure and behaviour. In ECMAScript, the state and methods are carried by objects, and structure, behaviour, and state are all inherited.

All objects that do not directly contain a particular property that their prototype contains share that property and its value. The following diagram illustrates this:

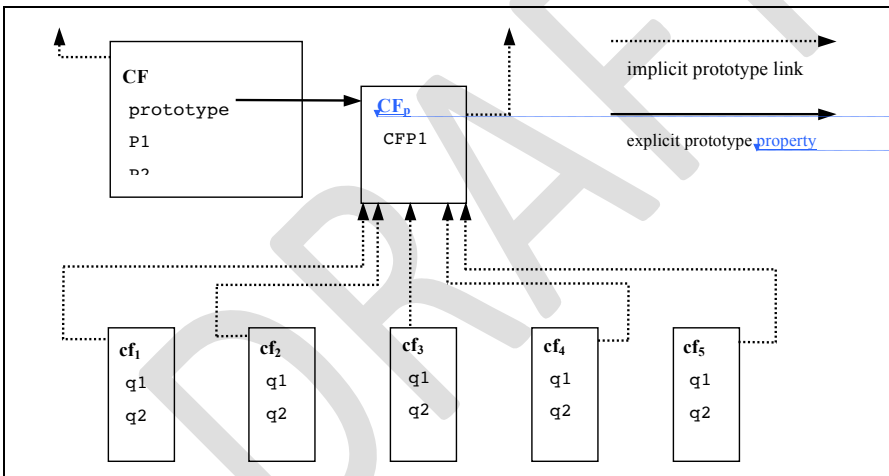

CF is a constructor (and also an object). Five objects have been created by using **new** expressions: `cf1`, `cf2`, `cf3`, `cf4`, and `cf5`. Each of these objects contains properties named `q1` and `q2`. The dashed lines represent the implicit prototype relationship; so, for example, `cf3`'s prototype is `CFp`. The constructor, `CF`, has two properties itself, named `P1` and `P2`, which are not visible to `CFp`, `cf1`, `cf2`, `cf3`, `cf4`, or `cf5`. The property named `CFP1` in `CFp` is shared by `cf1`, `cf2`, `cf3`, `cf4`, and `cf5` (but not by `CF`), as are any properties found in `CFp`'s implicit prototype chain that are not named `q1`, `q2`, or `CFP1`. Notice that there is no implicit prototype link between `CF` and `CFp`.

Unlike class-based object languages, properties can be added to objects dynamically by assigning values to them. That is, constructors are not required to name or assign values to all or any of the constructed object's properties. In the above diagram, one could add a new shared property for `cf1`, `cf2`, `cf3`, `cf4`, and `cf5` by assigning a new value to the property in `CFp`.

#### 4.2.2 Voluntary Usage Language Subsets

The ECMAScript Language recognizes the possibility that some users of the language may wish to restrict their usage of some features available in the language. They might do so in the interests of security, to avoid what they consider to be error prone features, to get better error checking, or for other

pratapL 7/4/2008 10:07 AM  
**Comment [2]:** Rationale:  
 Consider window document. It is an object (typeof document should be 'object'), but it not a constructor (does not support the [[Construct]] property.

pratapL 5/27/2008 10:07 AM  
**Comment [3]:** From AWB: Need to make typography consistent.

pratapL 5/27/2008 4:01 PM  
**Deleted:** Prototype property

pratapL 5/27/2008 4:03 PM  
**Deleted:** constructor has an associated prototype, and every

pratapL 5/27/2008 4:03 PM  
**Deleted:** that

pratapL 5/27/2008 4:04 PM  
**Deleted:** to the prototype

pratapL 5/27/2008 4:04 PM  
**Deleted:** associated with its constructor

pratapL 3/25/2008 1:06 AM  
**Deleted:** Cf<sub>p</sub>

pratapL 5/27/2008 4:05 PM  
**Deleted:** link

reasons of their choosing. In support of this possibility, ECMAScript defines the concept of *usage subsets* of the language. A usage subset is simply a specified subset of the ECMAScript language. A usage subset may exclude specific syntactic and semantic features of the full ECMAScript language and may identify additional error conditions that could be reported by throwing error exceptions in situations that are not specified as errors by the full language.

A usage subset is not intended as a means of enabling implementations of subsets of ECMAScript. To conform to this specification, an ECMAScript implementation must implement the full language as defined by this specification. Instead, a usage subset is simply a way for a user of the language to state their intent to voluntarily restrict themselves to a well specified subset of the language. Implementations of ECMAScript may treat such statements of intent as a request from a user that they would like the implementation to help them ensure that they have actually adhered to the limitations of a subset. An implementation should honour such a request by reporting violations of a subset's syntactic and semantic restrictions and by detecting any additional error conditions and throwing the appropriate error exception. Because usage subsets are selected at the level of a syntactic program unit they may only impose restriction that would have local effect within such a syntactic program unit. They may not restrict the ECMAScript semantics that must operate consistently across all program units.

With one exception, an ECMAScript program that is voluntarily limited to a usage subset and which executes without error under the subset's restrictions will behave identically if executed without on any usage subset restrictions. The exception is any situation where the operation of such a program depends upon the actual occurrence and subsequent handling of additional error conditions that are part of the subset.

ECMAScript defines a single usage subset, named **cautious** which implementations must support to be in compliance with this specification. Other usage subsets may be defined by future versions of the ECMAScript language.

### 4.3 Definitions

The following are informal definitions of key terms associated with ECMAScript.

#### 4.3.1 Type

A *type* is a set of data values.

#### 4.3.2 Primitive Value

A *primitive value* is a member of one of the types **Undefined**, **Null**, **Boolean**, **Number**, or **String**. A primitive value is a datum that is represented directly at the lowest level of the language implementation.

#### 4.3.3 Object

An *object* is a member of the type **Object**. It is an unordered collection of properties.

#### 4.3.4 Constructor

A *constructor* is a Function object that creates and initialises objects. The value of a constructor's "prototype" property is a prototype object that is used to implement inheritance and shared properties.

#### 4.3.5 Prototype

A *prototype* is an object used to implement structure, state, and behaviour inheritance in ECMAScript. When a constructor creates an object, that object implicitly references the constructor's "prototype" property for the purpose of resolving property references. The constructor's "prototype" property can be referenced by the program expression `constructor.prototype`, and properties added to an object's prototype are shared, through inheritance, by all objects sharing the prototype.

#### 4.3.6 Native Object

A *native object* is any object supplied by an ECMAScript implementation independent of the host environment. Standard native objects are defined in this specification. Some native objects are built-in; others may be constructed during the course of execution of an ECMAScript program.

#### 4.3.7 Built-in Object

A *built-in object* is any object supplied by an ECMAScript implementation, independent of the host environment, which is present at the start of the execution of an ECMAScript program. Standard built-in

pratapL 6/16/2008 8:50 AM

**Deleted:** It is an unordered collection of properties each of which contains a primitive value, object, or function. A function stored in a property of an object is called a method.

pratapL 5/27/2008 4:10 PM

**Deleted:** Each constructor has an associated

pratapL 5/27/2008 4:15 PM

**Deleted:** associated prototype

pratapL 5/27/2008 4:15 PM

**Deleted:** associated prototype

objects are defined in this specification, and an ECMAScript implementation may specify and define others. Every built-in object is a native object. [A built-in constructor is a built-in object that is also a constructor.](#)

#### 4.3.8 Host Object

A *host object* is any object supplied by the host environment to complete the execution environment of ECMAScript. Any object that is not native is a host object.

#### 4.3.9 Undefined Value

The *undefined value* is a primitive value used when a variable has not been assigned a value.

#### 4.3.10 Undefined Type

The type **Undefined** has exactly one value, called **undefined**.

#### 4.3.11 Null Value

The *null value* is a primitive value that represents the null, empty, or non-existent reference.

#### 4.3.12 Null Type

The type **Null** has exactly one value, called **null**.

#### 4.3.13 Boolean Value

A *boolean value* is a member of the type **Boolean** and is one of two unique values, **true** and **false**.

#### 4.3.14 Boolean Type

The type **Boolean** represents a logical entity and consists of exactly two unique values. One is called **true** and the other is called **false**.

#### 4.3.15 Boolean Object

A *Boolean object* is a member of the type **Object** and is an instance of the built-in Boolean object. That is, a Boolean object is created by using the Boolean constructor in a **new** expression, supplying a boolean as an argument. The resulting object has an implicit (unnamed) property that is the boolean. A Boolean object can be coerced to a boolean value.

#### 4.3.16 String Value

A *string value* is a member of the type **String** and is a finite ordered sequence of zero or more 16-bit unsigned integer values.

##### NOTE

*Although each value usually represents a single 16-bit unit of UTF-16 text, the language does not place any restrictions or requirements on the values except that they be 16-bit unsigned integers.*

#### 4.3.17 String Type

The type **String** is the set of all string values.

#### 4.3.18 String Object

A *String object* is a member of the type **Object** and is an instance of the built-in String object. That is, a String object is created by using the String constructor in a **new** expression, supplying a string as an argument. The resulting object has an implicit (unnamed) property that is the string. A String object can be coerced to a string value by calling the String constructor as a function (15.5.1).

#### 4.3.19 Number Value

A *number value* is a member of the type **Number** and is a direct representation of a number.

#### 4.3.20 Number Type

The type **Number** is a set of values representing numbers. In ECMAScript, the set of values represents the double-precision 64-bit format IEEE 754 values including the special “Not-a-Number” (NaN) values, positive infinity, and negative infinity.

#### 4.3.21 Number Object

A *Number object* is a member of the type **Object** and is an instance of the built-in Number object. That is, a Number object is created by using the Number constructor in a **new** expression, supplying a number

as an argument. The resulting object has an implicit (unnamed) property that is the number. A Number object can be coerced to a number value by calling the Number constructor as a function (15.7.1).

**4.3.22 Infinity**

The primitive value **Infinity** represents the positive infinite number value. This value is a member of the Number type.

**4.3.23 NaN**

The primitive value **NaN** represents the set of IEEE Standard “Not-a-Number” values. This value is a member of the Number type.

**4.3.24 Function**

A **function** is a member of the type **Object** and is an instance of the built-in Function object. In addition to its named properties, a function contains executable code and state that determine how it behaves when invoked. A function’s code may or may not be written in ECMAScript.

**4.3.25 Property**

A **property** is an association between a name and a value. Depending upon the form of the property the value may be either a data value (a primitive value, an object, or a function) or a pair of functions.

**4.3.26 Method**

A **method** is a function that is the value of a property.

**4.3.27 Attribute**

An **attribute** is an internal value that defines some characteristic of a property.

**4.3.29 Own Property**

An own property of an object is a property that is directly defined by that object.

**4.3.28 Inherited Property**

An **inherited property** is a property of an object that is not one of its own properties but is a property (either own or inherited) of the object’s prototype.

**4.3.29 Built-in Method**

A **built-in method** is any method supplied by an ECMAScript implementation, independent of the host environment, which is present at the start of the execution of an ECMAScript program. Standard built-in methods are defined in this specification, and an ECMAScript implementation may specify and define others.

## 5 Notational Conventions

### 5.1 Syntactic and Lexical Grammars

This section describes the context-free grammars used in this specification to define the lexical and syntactic structure of an ECMAScript program.

#### 5.1.1 Context-Free Grammars

A *context-free grammar* consists of a number of *productions*. Each production has an abstract symbol called a *nonterminal* as its *left-hand side*, and a sequence of zero or more nonterminal and *terminal* symbols as its *right-hand side*. For each grammar, the terminal symbols are drawn from a specified alphabet.

Starting from a sentence consisting of a single distinguished nonterminal, called the *goal symbol*, a given context-free grammar specifies a *language*, namely, the (perhaps infinite) set of possible sequences of terminal symbols that can result from repeatedly replacing any nonterminal in the sequence with a right-hand side of a production for which the nonterminal is the left-hand side.

#### 5.1.2 The Lexical and RegExp Grammars

A *lexical grammar* for ECMAScript is given in clause 7. This grammar has as its terminal symbols the characters of the Unicode character set. It defines a set of productions, starting from the goal symbol *InputElementDiv* or *InputElementRegExp*, that describe how sequences of Unicode characters are translated into a sequence of input elements.

Input elements other than white space and comments form the terminal symbols for the syntactic grammar for ECMAScript and are called ECMAScript *tokens*. These tokens are the reserved words, identifiers, literals, and punctuators of the ECMAScript language. Moreover, line terminators, although not considered to be tokens, also become part of the stream of input elements and guide the process of automatic semicolon insertion (7.9). Simple white space and single-line comments are discarded and do not appear in the stream of input elements for the syntactic grammar. A *MultiLineComment* (that is, a comment of the form “/\*...\*/” regardless of whether it spans more than one line) is likewise simply discarded if it contains no line terminator; but if a *MultiLineComment* contains one or more line terminators, then it is replaced by a single line terminator, which becomes part of the stream of input elements for the syntactic grammar.

A *RegExp grammar* for ECMAScript is given in 15.10. This grammar also has as its terminal symbols the characters of the Unicode character set. It defines a set of productions, starting from the goal symbol *Pattern*, that describe how sequences of Unicode characters are translated into regular expression patterns.

Productions of the lexical and RegExp grammars are distinguished by having two colons “: :” as separating punctuation. The lexical and RegExp grammars share some productions.

#### 5.1.3 The Numeric String Grammar

A second grammar is used for translating strings into numeric values. This grammar is similar to the part of the lexical grammar having to do with numeric literals and has as its terminal symbols the characters of the Unicode character set. This grammar appears in 9.3.1.

Productions of the numeric string grammar are distinguished by having three colons “: : :” as punctuation.

#### 5.1.4 The Syntactic Grammar

The *syntactic grammar* for ECMAScript is given in clauses 11, 12, 13 and 14. This grammar has ECMAScript tokens defined by the lexical grammar as its terminal symbols (5.1.2). It defines a set of productions, starting from the goal symbol *Program*, that describe how sequences of tokens can form syntactically correct ECMAScript programs.

When a stream of Unicode characters is to be parsed as an ECMAScript program, it is first converted to a stream of input elements by repeated application of the lexical grammar; this stream of input elements is then parsed by a single application of the syntax grammar. The program is syntactically in error if the tokens in the stream of input elements cannot be parsed as a single instance of the goal nonterminal *Program*, with no tokens left over.

pratapL 3/25/2008 1:07 AM

Deleted: 7.8.5

Productions of the syntactic grammar are distinguished by having just one colon “:” as punctuation.

The syntactic grammar as presented in sections 0, 0, 0 and 0 is actually not a complete account of which token sequences are accepted as correct ECMAScript programs. Certain additional token sequences are also accepted, namely, those that would be described by the grammar if only semicolons were added to the sequence in certain places (such as before line terminator characters). Furthermore, certain token sequences that are described by the grammar are not considered acceptable if a terminator character appears in certain “awkward” places.

pratapL 7/4/2008 10:07 AM  
**Comment [4]:** Fix this up with the right section numbers.

### 5.1.5 Grammar Notation

Terminal symbols of the lexical and string grammars, and some of the terminal symbols of the syntactic grammar, are shown in **fixed width** font, both in the productions of the grammars and throughout this specification whenever the text directly refers to such a terminal symbol. These are to appear in a program exactly as written. All nonterminal characters specified in this way are to be understood as the appropriate Unicode character from the ASCII range, as opposed to any similar-looking characters from other Unicode ranges.

Nonterminal symbols are shown in *italic* type. The definition of a nonterminal is introduced by the name of the nonterminal being defined followed by one or more colons. (The number of colons indicates to which grammar the production belongs.) One or more alternative right-hand sides for the nonterminal then follow on succeeding lines. For example, the syntactic definition:

*WhileStatement* :

**while** ( *Expression* ) *Statement*

states that the nonterminal *WhileStatement* represents the token **while**, followed by a left parenthesis token, followed by an *Expression*, followed by a right parenthesis token, followed by a *Statement*. The occurrences of *Expression* and *Statement* are themselves nonterminals. As another example, the syntactic definition:

*ArgumentList* :

*AssignmentExpression*  
*ArgumentList* , *AssignmentExpression*

states that an *ArgumentList* may represent either a single *AssignmentExpression* or an *ArgumentList*, followed by a comma, followed by an *AssignmentExpression*. This definition of *ArgumentList* is *recursive*, that is, it is defined in terms of itself. The result is that an *ArgumentList* may contain any positive number of arguments, separated by commas, where each argument expression is an *AssignmentExpression*. Such recursive definitions of nonterminals are common.

The subscripted suffix “*opt*”, which may appear after a terminal or nonterminal, indicates an *optional symbol*. The alternative containing the optional symbol actually specifies two right-hand sides, one that omits the optional element and one that includes it. This means that:

*VariableDeclaration* :

*Identifier Initialiser*<sub>opt</sub>

is a convenient abbreviation for:

*VariableDeclaration* :

*Identifier*  
*Identifier Initialiser*

and that:

*IterationStatement* :

**for** ( *ExpressionNoIn*<sub>opt</sub> ; *Expression*<sub>opt</sub> ; *Expression*<sub>opt</sub> ) *Statement*

is a convenient abbreviation for:

*IterationStatement* :

**for** ( ; *Expression*<sub>opt</sub> ; *Expression*<sub>opt</sub> ) *Statement*  
**for** ( *ExpressionNoIn* ; *Expression*<sub>opt</sub> ; *Expression*<sub>opt</sub> ) *Statement*

which in turn is an abbreviation for:

pratapL 7/2/2008 5:11 AM  
**Deleted:** *WithStatement*

pratapL 7/2/2008 5:11 AM  
**Deleted:** **with**

pratapL 7/2/2008 5:11 AM  
**Deleted:** *WithStatement*

pratapL 7/2/2008 5:12 AM  
**Deleted:** **with**

*IterationStatement* :

```
for ( ; ; Expressionopt ) Statement
for ( ; Expression ; Expressionopt ) Statement
for ( ExpressionNoIn ; ; Expressionopt ) Statement
for ( ExpressionNoIn ; Expression ; Expressionopt ) Statement
```

which in turn is an abbreviation for:

*IterationStatement* :

```
for ( ; ; ) Statement
for ( ; ; Expression ) Statement
for ( ; Expression ; ) Statement
for ( ; Expression ; Expression ) Statement
for ( ExpressionNoIn ; ; ) Statement
for ( ExpressionNoIn ; ; Expression ) Statement
for ( ExpressionNoIn ; Expression ; ) Statement
for ( ExpressionNoIn ; Expression ; Expression ) Statement
```

so the nonterminal *IterationStatement* actually has eight alternative right-hand sides.

If the phrase “[empty]” appears as the right-hand side of a production, it indicates that the production's right-hand side contains no terminals or nonterminals.

If the phrase “[lookahead  $\notin$  set]” appears in the right-hand side of a production, it indicates that the production may not be used if the immediately following input terminal is a member of the given *set*. The *set* can be written as a list of terminals enclosed in curly braces. For convenience, the set can also be written as a nonterminal, in which case it represents the set of all terminals to which that nonterminal could expand. For example, given the definitions

```
DecimalDigit :: one of
0 1 2 3 4 5 6 7 8 9
```

```
DecimalDigits ::
DecimalDigit
DecimalDigits DecimalDigit
```

the definition

```
LookaheadExample ::
n [lookahead  $\notin$  {1, 3, 5, 7, 9}] DecimalDigits
DecimalDigit [lookahead  $\notin$  DecimalDigit ]
```

matches either the letter **n** followed by one or more decimal digits the first of which is even, or a decimal digit not followed by another decimal digit.

If the phrase “[no *LineTerminator* here]” appears in the right-hand side of a production of the syntactic grammar, it indicates that the production is a *restricted production*: it may not be used if a *LineTerminator* occurs in the input stream at the indicated position. For example, the production:

```
ReturnStatement :
return [no LineTerminator here] Expressionopt ;
```

indicates that the production may not be used if a *LineTerminator* occurs in the program between the **return** token and the *Expression*.

Unless the presence of a *LineTerminator* is forbidden by a restricted production, any number of occurrences of *LineTerminator* may appear between any two consecutive tokens in the stream of input elements without affecting the syntactic acceptability of the program.

When the words “**one of**” follow the colon(s) in a grammar definition, they signify that each of the terminal symbols on the following line or lines is an alternative definition. For example, the lexical grammar for ECMAScript contains the production:

*NonZeroDigit* :: one of  
1 2 3 4 5 6 7 8 9

which is merely a convenient abbreviation for:

*NonZeroDigit* ::  
1  
2  
3  
4  
5  
6  
7  
8  
9

pratapL 3/25/2008 1:08 AM  
Deleted: one of

When an alternative in a production of the lexical grammar or the numeric string grammar appears to be a multi-character token, it represents the sequence of characters that would make up such a token.

The right-hand side of a production may specify that certain expansions are not permitted by using the phrase “**but not**” and then indicating the expansions to be excluded. For example, the production:

*Identifier* ::

*IdentifierName* but **not** *ReservedWord*

means that the nonterminal *Identifier* may be replaced by any sequence of characters that could replace *IdentifierName* provided that the same sequence of characters could not replace *ReservedWord*.

Finally, a few nonterminal symbols are described by a descriptive phrase in roman type in cases where it would be impractical to list all the alternatives:

*SourceCharacter* ::

any Unicode character

## 5.2 Algorithm Conventions

The specification often uses a numbered list to specify steps in an algorithm. These algorithms are used to clarify semantics. In practice, there may be more efficient algorithms available to implement a given feature.

When an algorithm is to produce a value as a result, the directive “return *x*” is used to indicate that the result of the algorithm is the value of *x* and that the algorithm should terminate. The notation *Result*(*n*) is used as shorthand for “the result of step *n*”. *Type*(*x*) is used as shorthand for “the type of *x*”.

For clarity of expression, algorithm steps may be subdivided into sequential substeps. Substeps are indented and may themselves be further divided into indented substeps. Outline numbering conventions are used to identify substeps with the first level of substeps labeled with lower case alphabetic characters and the second level of substeps labelled with lower case roman numerals. If more than three levels are required these rules repeat with the fourth level using numeric labels. For example:

- Top-level step
- Substep
- Substep
- Subsubstep
- Subsubstep
- Subsubsubstep
- Subsubsubsubstep

A step or substep may be written as a predicate that conditions its substeps. In this case, the substeps are only applied if the predicate is true. If a step or substep begins with the word “else” it is a predicate that is the negation of the preceding predicate step at the same level. If “else” is immediately followed by a parenthesized step or substep label then it is a predicate that is the negation of that labelled predicate.



[A step my specify the iterative application of its substeps.](#)

Mathematical operations such as addition, subtraction, negation, multiplication, division, and the mathematical functions defined later in this section should always be understood as computing exact mathematical results on mathematical real numbers, which do not include infinities and do not include a negative zero that is distinguished from positive zero. Algorithms in this standard that model floating-point arithmetic include explicit steps, where necessary, to handle infinities and signed zero and to perform rounding. If a mathematical operation or function is applied to a floating-point number, it should be understood as being applied to the exact mathematical value represented by that floating-point number; such a floating-point number must be finite, and if it is **+0** or **-0** then the corresponding mathematical value is simply 0.

The mathematical function `abs(x)` yields the absolute value of  $x$ , which is  $-x$  if  $x$  is negative (less than zero) and otherwise is  $x$  itself.

The mathematical function `sign(x)` yields 1 if  $x$  is positive and  $-1$  if  $x$  is negative. The sign function is not used in this standard for cases when  $x$  is zero.

The notation “ $x$  modulo  $y$ ” ( $y$  must be finite and nonzero) computes a value  $k$  of the same sign as  $y$  (or zero) such that  $\text{abs}(k) < \text{abs}(y)$  and  $x - k = q \times y$  for some integer  $q$ .

The mathematical function `floor(x)` yields the largest integer (closest to positive infinity) that is not larger than  $x$ .

NOTE

`floor(x) = x - (x modulo 1)`.

If an algorithm is defined to “throw an exception”, execution of the algorithm is terminated and no result is returned. The calling algorithms are also terminated, until an algorithm step is reached that explicitly deals with the exception, using terminology such as “If an exception was thrown...”. Once such an algorithm step has been encountered the exception is no longer considered to have occurred.

## 6. Source Text

ECMAScript source text is represented as a sequence of characters in the Unicode character encoding, version [3.0](#) or later, using the UTF-16 transformation format. The text is expected to have been normalised to Unicode Normalised Form C (canonical composition), as described in Unicode Technical Report #15. Conforming ECMAScript implementations are not required to perform any normalisation of text, or behave as though they were performing normalisation of text, themselves.

*SourceCharacter* ::  
any Unicode character

ECMAScript source text can contain any of the Unicode characters. All Unicode white space characters are treated as white space. [Only the carriage return and line feed characters](#) are treated as line separators. Non-Latin Unicode characters are allowed in identifiers, string literals, regular expression literals and comments.

Throughout the rest of this document, the phrase “code point” and the word “character” will be used to refer to a 16-bit unsigned value used to represent a single 16-bit unit of UTF-16 text. The phrase “Unicode character” will be used to refer to the abstract linguistic or typographical unit represented by a single Unicode scalar value (which may be longer than 16 bits and thus may be represented by more than one code point). This only refers to entities represented by single Unicode scalar values: the components of a combining character sequence are still individual “Unicode characters,” even though a user might think of the whole sequence as a single character.

In string literals, regular expression literals and identifiers, any character (code point) may also be expressed as a Unicode escape sequence consisting of six characters, namely `\u` plus four hexadecimal digits. Within a comment, such an escape sequence is effectively ignored as part of the comment. Within a string literal or regular expression literal, the Unicode escape sequence contributes one character to the value of the literal. Within an identifier, the escape sequence contributes one character to the identifier.

NOTE 1

pratapL 6/10/2008 7:15 PM

Deleted: 2.1

pratapL 7/2/2008 5:14 AM

Deleted: , and all Unicode line/paragraph separators

Although this document sometimes refers to a “transformation” between a “character” within a “string” and the 16-bit unsigned integer that is the UTF-16 encoding of that character, there is actually no transformation because a “character” within a “string” is actually represented using that 16-bit unsigned value.

NOTE 2

ECMAScript differs from the Java programming language in the behaviour of Unicode escape sequences. In a Java program, if the Unicode escape sequence `\u000A`, for example, occurs within a single-line comment, it is interpreted as a line terminator (Unicode character `000A` is line feed) and therefore the next character is not part of the comment. Similarly, if the Unicode escape sequence `\u000A` occurs within a string literal in a Java program, it is likewise interpreted as a line terminator, which is not allowed within a string literal—one must write `\n` instead of `\u000A` to cause a line feed to be part of the string value of a string literal. In an ECMAScript program, a Unicode escape sequence occurring within a comment is never interpreted and therefore cannot contribute to termination of the comment. Similarly, a Unicode escape sequence occurring within a string literal in an ECMAScript program always contributes a character to the string value of the literal and is never interpreted as a line terminator or as a quote mark that might terminate the string literal.

## 7 Lexical Conventions

The source text of an ECMAScript program is first converted into a sequence of input elements, which are either tokens, line terminators, comments, or white space. The source text is scanned from left to right, repeatedly taking the longest possible sequence of characters as the next input element.

There are two goal symbols for the lexical grammar. The *InputElementDiv* symbol is used in those syntactic grammar contexts where a division (*/*) or division-assignment (*/=*) operator is permitted. The *InputElementRegExp* symbol is used in other syntactic grammar contexts.

Note that contexts exist in the syntactic grammar where both a division and a *RegularExpressionLiteral* are permitted by the syntactic grammar; however, since the lexical grammar uses the *InputElementDiv* goal symbol in such cases, the opening slash is not recognised as starting a regular expression literal in such a context. As a workaround, one may enclose the regular expression literal in parentheses.

### Syntax

*InputElementDiv* ::  
WhiteSpace  
LineTerminator  
Comment  
Token  
DivPunctuator

*InputElementRegExp* ::  
WhiteSpace  
LineTerminator  
Comment  
Token  
RegularExpressionLiteral

### 7.1 Unicode Format-Control Characters

The Unicode format-control characters (i.e., the characters in category “CF” in the Unicode Character Database such as LEFT-TO-RIGHT MARK or RIGHT-TO-LEFT MARK) are control codes used to control the formatting of a range of text in the absence of higher-level protocols for this (such as mark-up languages). It is useful to allow these in source text to facilitate editing and display.

The format control characters [maybe used in identifiers, within comments, and within string literals and regular expression literals.](#)

### 7.2 White Space

White space characters are used to improve source text readability and to separate tokens (indivisible lexical units) from each other, but are otherwise insignificant. White space may occur between any two tokens, and may occur within strings (where they are considered significant characters forming part of the literal string value), but cannot appear within any other kind of token.

pratapL 7/2/2008 10:48 AM  
**Deleted:** can occur

pratapL 7/2/2008 5:16 AM  
**Deleted:** anywhere in the source text of an ECMAScript program. These characters are removed from the source text before applying the lexical grammar. Since these characters are removed before processing string and regular expression literals, one must use a Unicode escape sequence (see 7.6) to include a Unicode format-control character inside a string or regular expression literal

The following characters are considered to be white space:

Code Point Value	Name	Formal Name
\u0009	Tab	<TAB>
\u000B	Vertical Tab	<VT>
\u000C	Form Feed	<FF>
\u0020	Space	<SP>
<a href="#">\u0085</a>	<a href="#">Next Line</a>	<a href="#">&lt;NEL&gt;</a>
\u00A0	No-break space	<NBSP>
<a href="#">\u200B</a>	<a href="#">Zero width space</a>	<a href="#">&lt;ZWSP&gt;</a>
<a href="#">\u2028</a>	<a href="#">Line separator</a>	<a href="#">&lt;LS&gt;</a>
<a href="#">\u2029</a>	<a href="#">Paragraph separator</a>	<a href="#">&lt;PS&gt;</a>
<a href="#">\uFEFF</a>	<a href="#">Byte Order Mark</a>	<a href="#">&lt;BOM&gt;</a>
Other category “Zs”	Any other Unicode “space separator”	<USP>

[ECMAScript implementations must recognize all of the white space characters defined in Unicode 3.0. Later editions of the Unicode Standard may define other white space characters. ECMAScript implementations may recognize white space characters from later editions of the Unicode Standard.](#)

**Syntax**

WhiteSpace ::  
 <TAB>  
 <VT>  
 <FF>  
 <SP>  
[<NEL>](#)  
 <NBSP>  
[<ZWSP>](#)  
[<LS>](#)  
[<PS>](#)  
[<BOM>](#)  
 <USP>

**7.3 Line Terminators**

Like white space characters, line terminator characters are used to improve source text readability and to separate tokens (indivisible lexical units) from each other. However, unlike white space characters, line terminators have some influence over the behaviour of the syntactic grammar. In general, line terminators may occur between any two tokens, but there are a few places where they are forbidden by the syntactic grammar. A line terminator cannot occur within any token, [except that line terminators that are preceded by an escape sequence may occur within a string literal token](#). Line terminators also affect the process of automatic semicolon insertion ([7.9](#)).

[Line terminators are included in the set of white space characters that are matched by the \s class in regular expressions.](#)

The following characters are considered to be line terminators:

Code Point Value	Name	Formal Name
\u000A	Line Feed	<LF>
\u000D	Carriage Return	<CR>

pratapL 7/2/2008 10:52 AM  
 Deleted: not even a string

pratapL 3/25/2008 1:09 AM  
 Deleted: 7.8.5

pratapL 5/28/2008 6:53 PM  
 Deleted: \u2028 ... [1]

Only Line Feed and Carriage Return may be treated as line terminators. Other new line or line breaking characters are treated as white space but not as line terminators.

**Syntax**

*LineTerminator* ::  
<LF>  
<CR>

**7.4 Comments**  
**Description**

Comments can be either single or multi-line. Multi-line comments cannot nest.

Because a single-line comment can contain any character except a *LineTerminator* character, and because of the general rule that a token is always as long as possible, a single-line comment always consists of all characters from the // marker to the end of the line. However, the *LineTerminator* at the end of the line is not considered to be part of the single-line comment; it is recognised separately by the lexical grammar and becomes part of the stream of input elements for the syntactic grammar. This point is very important, because it implies that the presence or absence of single-line comments does not affect the process of automatic semicolon insertion (7.9).

Comments behave like white space and are discarded except that, if a *MultiLineComment* contains a line terminator character, then the entire comment is considered to be a *LineTerminator* for purposes of parsing by the syntactic grammar.

**Syntax**

*Comment* ::  
*MultiLineComment*  
*SingleLineComment*

*MultiLineComment* ::  
/\* *MultiLineCommentChars*<sub>opt</sub> \*/

*MultiLineCommentChars* ::  
*MultiLineNotAsteriskChar* *MultiLineCommentChars*<sub>opt</sub>  
\* *PostAsteriskCommentChars*<sub>opt</sub>

*PostAsteriskCommentChars* ::  
*MultiLineNotForwardSlashOrAsteriskChar* *MultiLineCommentChars*<sub>opt</sub>  
\* *PostAsteriskCommentChars*<sub>opt</sub>

*MultiLineNotAsteriskChar* ::  
*SourceCharacter* **but not asterisk** \*

*MultiLineNotForwardSlashOrAsteriskChar* ::  
*SourceCharacter* **but not forward-slash / or asterisk** \*

*SingleLineComment* ::  
// *SingleLineCommentChars*<sub>opt</sub>

*SingleLineCommentChars* ::  
*SingleLineCommentChar* *SingleLineCommentChars*<sub>opt</sub>

*SingleLineCommentChar* ::  
*SourceCharacter* **but not LineTerminator**

**7.5 Tokens**

**Syntax**

pratapL 5/28/2008 6:53 PM  
**Deleted:** <LS> ..  
<PS>

Token ::  
ReservedWord  
Identifier  
IdentifierName  
Punctuator  
NumericLiteral  
StringLiteral

### 7.5.1 Reserved Words

Description

Reserved words cannot be used as identifiers.

#### Syntax

ReservedWord ::  
Keyword  
FutureReservedWord  
NullLiteral  
BooleanLiteral

### 7.5.2 Keywords

The following tokens are ECMAScript keywords and may not be used as identifiers in ECMAScript programs.

#### Syntax

Keyword :: one of

<a href="#">break</a>	else	new	var
case	finally	return	void
catch	for	switch	while
continue	function	this	with
default	if	throw	<a href="#">debugger</a>
delete	in	try	<a href="#">const</a>
do	instanceof	typeof	

### 7.5.3 Future Reserved Words

The following words are used as keywords in proposed extensions and are therefore reserved to allow for the possibility of future adoption of those extensions.

#### Syntax

FutureReservedWord :: one of

abstract	enum	int	short
boolean	export	interface	static
byte	extends	long	super
char	final	native	synchronized
class	float	package	throws
<a href="#">▼</a>	goto	private	transient
<a href="#">▼</a>	<a href="#">implements</a>	protected	volatile
double	import	public	

### 7.6 Identifiers

#### Description

Identifiers are interpreted according to the grammar given in Section 5.16 of the [Unicode standard](#), with some small modifications. This grammar is based on both normative and informative character categories specified by the Unicode [Standard](#). The characters in the specified categories in version [3.0](#) of the Unicode standard must be treated as in those categories by all conforming ECMAScript implementations.

This standard specifies [specific character additions](#): The dollar sign (\$) and the underscore ( ) are permitted anywhere in an identifier.

- pratapL 7/2/2008 10:58 AM  
**Deleted:** Break
- pratapL 7/4/2008 10:07 AM  
**Comment [5]:** Specify that its normative semantics is simply a noop, but advise in an annex that it causes a breakpoint when run under a debugger.
- pratapL 7/4/2008 10:07 AM  
**Comment [6]:** From AWB: Does it get defined as a statement or as something that can occur in an expression. Wouldn't defining it as a "getter" property of the global object accomplish the same thing without reserving it.
- pratapL 5/28/2008 6:56 PM  
**Deleted:** const
- pratapL 7/4/2008 10:07 AM  
**Comment [7]:** This table needs to be repacked to get rid of the holes.
- pratapL 5/27/2008 5:02 PM  
**Deleted:** debugger
- pratapL 7/2/2008 5:27 AM  
**Deleted:** upcoming version 3.0 of the
- pratapL 7/2/2008 11:01 AM  
**Deleted:** standard
- pratapL 6/11/2008 3:02 PM  
**Deleted:** 2.1
- pratapL 5/29/2008 7:42 AM  
**Deleted:** ; however, conforming ECMAScript implementations may allow additional legal identifier characters based on the category assignment from later versions of Unicode
- pratapL 7/2/2008 5:28 AM  
**Deleted:** one departure from the grammar given in the Unicode standard
- pratapL 5/28/2008 6:58 PM  
**Deleted:** The dollar sign is intended for use only in mechanically generated code.

Unicode escape sequences are also permitted in identifiers, where they contribute a single character to the identifier, as computed by the CV of the *UnicodeEscapeSequence* (see 7.8.4). The `\` preceding the *UnicodeEscapeSequence* does not contribute a character to the identifier. A *UnicodeEscapeSequence* cannot be used to put a character into an identifier that would otherwise be illegal. In other words, if a `\ UnicodeEscapeSequence` sequence were replaced by its *UnicodeEscapeSequence*'s CV, the result must still be a valid *Identifier* that has the exact same sequence of characters as the original *Identifier*.

Two identifiers that are canonically equivalent according to the Unicode standard are *not* equal unless they are represented by the exact same sequence of code points (in other words, conforming ECMAScript implementations are only required to do bitwise comparison on identifiers). The intent is that the incoming source text has been converted to normalised form C before it reaches the compiler.

[ECMAScript implementations may recognize identifier characters defined in later editions of the Unicode Standard. If portability is a concern, programmers should only employ identifier characters defined in Unicode 3.0.](#)

#### Syntax

*Identifier* ::

*IdentifierName* **but not** *ReservedWord*

*IdentifierName* ::

*IdentifierStart*

*IdentifierName* *IdentifierPart*

*IdentifierStart* ::

*UnicodeLetter*

`$`

`\` *UnicodeEscapeSequence*

*IdentifierPart* ::

*IdentifierStart*

*UnicodeCombiningMark*

*UnicodeDigit*

*UnicodeConnectorPunctuation*

`\` *UnicodeEscapeSequence*

*UnicodeLetter*

any character in the Unicode categories “Uppercase letter (Lu)”, “Lowercase letter (Ll)”, “Titlecase letter (Lt)”, “Modifier letter (Lm)”, “Other letter (Lo)”, or “Letter number (Nl)”.

*UnicodeCombiningMark*

any character in the Unicode categories “Non-spacing mark (Mn)” or “Combining spacing mark (Mc)”

*UnicodeDigit*

any character in the Unicode category “Decimal number (Nd)”

*UnicodeConnectorPunctuation*

any character in the Unicode category “Connector punctuation (Pc)”

*UnicodeEscapeSequence*

see 7.8.4.

*HexDigit* :: one of

0 1 2 3 4 5 6 7 8 9 a b c d e f A B C D E F

## 7.7 Punctuators

### Syntax

*Punctuator* :: one of

{	}	(	)	[	]
.	;	,	<	>	<=
>=	==	!=	===	!==	
+	-	*	%	++	--
<<	>>	>>>	&		^
!	~	&&		?	:
=	+=	-=	*=	%=	<<=
>>=	>>>=	&=	=	^=	

*DivPunctuator* :: one of

/ /=

## 7.8 Literals

### Syntax

*Literal* ::

*NullLiteral*  
*BooleanLiteral*  
*NumericLiteral*  
*StringLiteral*

#### 7.8.1 Null Literals

### Syntax

*NullLiteral* ::  
**null**

### Semantics

The value of the null literal **null** is the sole value of the Null type, namely **null**.

#### 7.8.2 Boolean Literals

### Syntax

*BooleanLiteral* ::  
**true**  
**false**

### Semantics

The value of the Boolean literal **true** is a value of the Boolean type, namely **true**.

The value of the Boolean literal **false** is a value of the Boolean type, namely **false**.

#### 7.8.3 Numeric Literals

### Syntax

*NumericLiteral* ::  
*DecimalLiteral*  
*HexIntegerLiteral*

*DecimalLiteral* ::

*DecimalIntegerLiteral* . *DecimalDigits*<sub>opt</sub> *ExponentPart*<sub>opt</sub>  
. *DecimalDigits* *ExponentPart*<sub>opt</sub>  
*DecimalIntegerLiteral* *ExponentPart*<sub>opt</sub>

*DecimalIntegerLiteral* ::

**0**  
*NonZeroDigit* *DecimalDigits*<sub>opt</sub>

*DecimalDigits* ::  
    *DecimalDigit*  
    *DecimalDigits* *DecimalDigit*

*DecimalDigit* :: one of  
    0 1 2 3 4 5 6 7 8 9

*NonZeroDigit* :: one of  
    1 2 3 4 5 6 7 8 9

*ExponentPart* ::  
    *ExponentIndicator* *SignedInteger*

*ExponentIndicator* :: one of  
    e E

*SignedInteger* ::  
    *DecimalDigits*  
    + *DecimalDigits*  
    - *DecimalDigits*

*HexIntegerLiteral* ::  
    0x *HexDigit*  
    0X *HexDigit*  
    *HexIntegerLiteral* *HexDigit*

The source character immediately following a *NumericLiteral* must not be an *IdentifierStart* or *DecimalDigit*.

**NOTE**

For example:

**3in**

is an error and not the two input elements **3** and **in**.

**Semantics**

A numeric literal stands for a value of the Number type. This value is determined in two steps: first, a mathematical value (MV) is derived from the literal; second, this mathematical value is rounded as described below.

The MV of *NumericLiteral* :: *DecimalLiteral* is the MV of *DecimalLiteral*.

The MV of *NumericLiteral* :: *HexIntegerLiteral* is the MV of *HexIntegerLiteral*.

The MV of *DecimalLiteral* :: *DecimalIntegerLiteral* . is the MV of *DecimalIntegerLiteral*.

The MV of *DecimalLiteral* :: *DecimalIntegerLiteral* . *DecimalDigits* is the MV of *DecimalIntegerLiteral* plus (the MV of *DecimalDigits* times  $10^{-n}$ ), where  $n$  is the number of characters in *DecimalDigits*.

The MV of *DecimalLiteral* :: *DecimalIntegerLiteral* . *ExponentPart* is the MV of *DecimalIntegerLiteral* times  $10^e$ , where  $e$  is the MV of *ExponentPart*.

The MV of *DecimalLiteral* :: *DecimalIntegerLiteral* . *DecimalDigits* *ExponentPart* is (the MV of *DecimalIntegerLiteral* plus (the MV of *DecimalDigits* times  $10^{-n}$ )) times  $10^e$ , where  $n$  is the number of characters in *DecimalDigits* and  $e$  is the MV of *ExponentPart*.

The MV of *DecimalLiteral* :: . *DecimalDigits* is the MV of *DecimalDigits* times  $10^{-n}$ , where  $n$  is the number of characters in *DecimalDigits*.

The MV of *DecimalLiteral* :: . *DecimalDigits* *ExponentPart* is the MV of *DecimalDigits* times  $10^{e-n}$ , where  $n$  is the number of characters in *DecimalDigits* and  $e$  is the MV of *ExponentPart*.

The MV of *DecimalLiteral* :: *DecimalIntegerLiteral* is the MV of *DecimalIntegerLiteral*.

The MV of *DecimalLiteral* :: *DecimalIntegerLiteral* *ExponentPart* is the MV of *DecimalIntegerLiteral* times  $10^e$ , where  $e$  is the MV of *ExponentPart*.

The MV of *DecimalIntegerLiteral* :: 0 is 0.



The MV of *DecimalIntegerLiteral* :: *NonZeroDigit* *DecimalDigits* is (the MV of *NonZeroDigit* times  $10^n$ ) plus the MV of *DecimalDigits*, where *n* is the number of characters in *DecimalDigits*.

The MV of *DecimalDigits* :: *DecimalDigit* is the MV of *DecimalDigit*.

The MV of *DecimalDigits* :: *DecimalDigits* *DecimalDigit* is (the MV of *DecimalDigits* times 10) plus the MV of *DecimalDigit*.

The MV of *ExponentPart* :: *ExponentIndicator* *SignedInteger* is the MV of *SignedInteger*.

The MV of *SignedInteger* :: *DecimalDigits* is the MV of *DecimalDigits*.

The MV of *SignedInteger* :: + *DecimalDigits* is the MV of *DecimalDigits*.

The MV of *SignedInteger* :: - *DecimalDigits* is the negative of the MV of *DecimalDigits*.

The MV of *DecimalDigit* :: 0 or of *HexDigit* :: 0 is 0.

The MV of *DecimalDigit* :: 1 or of *NonZeroDigit* :: 1 or of *HexDigit* :: 1 is 1.

The MV of *DecimalDigit* :: 2 or of *NonZeroDigit* :: 2 or of *HexDigit* :: 2 is 2.

The MV of *DecimalDigit* :: 3 or of *NonZeroDigit* :: 3 or of *HexDigit* :: 3 is 3.

The MV of *DecimalDigit* :: 4 or of *NonZeroDigit* :: 4 or of *HexDigit* :: 4 is 4.

The MV of *DecimalDigit* :: 5 or of *NonZeroDigit* :: 5 or of *HexDigit* :: 5 is 5.

The MV of *DecimalDigit* :: 6 or of *NonZeroDigit* :: 6 or of *HexDigit* :: 6 is 6.

The MV of *DecimalDigit* :: 7 or of *NonZeroDigit* :: 7 or of *HexDigit* :: 7 is 7.

The MV of *DecimalDigit* :: 8 or of *NonZeroDigit* :: 8 or of *HexDigit* :: 8 is 8.

The MV of *DecimalDigit* :: 9 or of *NonZeroDigit* :: 9 or of *HexDigit* :: 9 is 9.

The MV of *HexDigit* :: a or of *HexDigit* :: A is 10.

The MV of *HexDigit* :: b or of *HexDigit* :: B is 11.

The MV of *HexDigit* :: c or of *HexDigit* :: C is 12.

The MV of *HexDigit* :: d or of *HexDigit* :: D is 13.

The MV of *HexDigit* :: e or of *HexDigit* :: E is 14.

The MV of *HexDigit* :: f or of *HexDigit* :: F is 15.

The MV of *HexIntegerLiteral* :: 0x *HexDigit* is the MV of *HexDigit*.

The MV of *HexIntegerLiteral* :: 0X *HexDigit* is the MV of *HexDigit*.

The MV of *HexIntegerLiteral* :: *HexIntegerLiteral* *HexDigit* is (the MV of *HexIntegerLiteral* times 16) plus the MV of *HexDigit*.

Once the exact MV for a numeric literal has been determined, it is then rounded to a value of the Number type. If the MV is 0, then the rounded value is +0; otherwise, the rounded value must be *the* number value for the MV (in the sense defined in 8.5), unless the literal is a *DecimalLiteral* and the literal has more than 20 significant digits, in which case the number value may be either the number value for the MV of a literal produced by replacing each significant digit after the 20th with a 0 digit or the number value for the MV of a literal produced by replacing each significant digit after the 20th with a 0 digit and then incrementing the literal at the 20th significant digit position. A digit is *significant* if it is not part of an *ExponentPart* and

it is not 0; or

there is a nonzero digit to its left and there is a nonzero digit, not in the *ExponentPart*, to its right.

#### 7.8.4 String Literals

A string literal is zero or more characters enclosed in single or double quotes. Each character may be represented by an escape sequence. [All Unicode characters may appear literally in a string literal except for the closing quote character, backslash, carriage return, and line feed. Any character may appear in the form of an escape sequence.](#)

#### Syntax

*StringLiteral* ::

" *DoubleStringCharacters*<sub>opt</sub> "

' *SingleStringCharacters*<sub>opt</sub> '

*DoubleStringCharacters* ::

*DoubleStringCharacter* *DoubleStringCharacters*<sub>opt</sub>

*SingleStringCharacters* ::  
*SingleStringCharacter* *SingleStringCharacters*<sub>opt</sub>

*DoubleStringCharacter* ::  
*SourceCharacter* **but not double-quote " or backslash \ or LineTerminator**  
*\ EscapeSequence*  
*LineContinuation*

*SingleStringCharacter* ::  
*SourceCharacter* **but not single-quote ' or backslash \ or LineTerminator**  
*\ EscapeSequence*  
*LineContinuation*

*LineContinuation* ::  
*\ LineTerminator*

*EscapeSequence* ::  
*CharacterEscapeSequence*  
*0* [lookahead  $\notin$  *DecimalDigit*]  
*HexEscapeSequence*  
*UnicodeEscapeSequence*

*CharacterEscapeSequence* ::  
*SingleEscapeCharacter*  
*NonEscapeCharacter*

*SingleEscapeCharacter* :: **one of**  
*' " \ b f n r t v*

*NonEscapeCharacter* ::  
*SourceCharacter* **but not EscapeCharacter or LineTerminator** *or WhiteSpace*

*EscapeCharacter* ::  
*SingleEscapeCharacter*  
*DecimalDigit*  
*x*  
*u*

*HexEscapeSequence* ::  
*x HexDigit HexDigit*

*UnicodeEscapeSequence* ::  
*u HexDigit HexDigit HexDigit HexDigit*

The definitions of the nonterminal *HexDigit* is given in section 7.8.3. *SourceCharacter* is described in sections 2 and 6.

A string literal stands for a value of the *String* type. The string value (SV) of the literal is described in terms of character values (CV) contributed by the various parts of the string literal. As part of this process, some characters within the string literal are interpreted as having a mathematical value (MV), as described below or in section 7.8.3.

The SV of *StringLiteral* :: "" is the empty character sequence.

The SV of *StringLiteral* :: ' ' is the empty character sequence.

The SV of *StringLiteral* :: " *DoubleStringCharacters* " is the SV of *DoubleStringCharacters*.

The SV of *StringLiteral* :: ' *SingleStringCharacters* ' is the SV of *SingleStringCharacters*.

The SV of *DoubleStringCharacters* :: *DoubleStringCharacter* is a sequence of one character, the CV of *DoubleStringCharacter*.

pratapL 7/4/2008 10:07 AM

**Comment [8]:** From DEC:  
Do we really want to do this?

pratapL 7/4/2008 10:07 AM

**Comment [9]:** 4/4 browsers support this.

pratapL 7/4/2008 10:07 AM

**Comment [10]:** "\ " will now be a syntax error. This is to improve the reliability of "\ ". We want to allow embedded LineTerminators since 4/4 browsers support it, but we don't want to have tabs or other whitespace characters hiding after the "\".

pratapL 7/4/2008 10:07 AM

**Comment [11]:** From AWB:  
What happened to \u{} style escapes that I thought were being considered?

The SV of *DoubleStringCharacters* :: *DoubleStringCharacter DoubleStringCharacters* is a sequence of the CV of *DoubleStringCharacter* followed by all the characters in the SV of *DoubleStringCharacters* in order.

The SV of *SingleStringCharacters* :: *SingleStringCharacter* is a sequence of one character, the CV of *SingleStringCharacter*.

The SV of *SingleStringCharacters* :: *SingleStringCharacter SingleStringCharacters* is a sequence of the CV of *SingleStringCharacter* followed by all the characters in the SV of *SingleStringCharacters* in order.

The SV of *LineContinuation* :: *\ LineTerminator* is the empty character sequence.

The CV of *DoubleStringCharacter* :: *SourceCharacter* but not double-quote " or backslash \ or *LineTerminator* is the *SourceCharacter* character itself.

The CV of *DoubleStringCharacter* :: *\ EscapeSequence* is the CV of the *EscapeSequence*.

The CV of *SingleStringCharacter* :: *SourceCharacter* but not single-quote ' or backslash \ or *LineTerminator* is the *SourceCharacter* character itself.

The CV of *SingleStringCharacter* :: *\ EscapeSequence* is the CV of the *EscapeSequence*.

The CV of *EscapeSequence* :: *CharacterEscapeSequence* is the CV of the *CharacterEscapeSequence*.

The CV of *EscapeSequence* :: *0* [lookahead  $\notin$  *DecimalDigit*] is a <NUL> character (Unicode value 0000).

The CV of *EscapeSequence* :: *HexEscapeSequence* is the CV of the *HexEscapeSequence*.

The CV of *EscapeSequence* :: *UnicodeEscapeSequence* is the CV of the *UnicodeEscapeSequence*.

The CV of *CharacterEscapeSequence* :: *SingleEscapeCharacter* is the character whose code point value is determined by the *SingleEscapeCharacter* according to the following table:

Escape Sequence	Code Point Value	Name	Symbol
<code>\b</code>	<code>\u0008</code>	backspace	<BS>
<code>\t</code>	<code>\u0009</code>	horizontal tab	<HT>
<code>\n</code>	<code>\u000A</code>	line feed (new line)	<LF>
<code>\v</code>	<code>\u000B</code>	vertical tab	<VT>
<code>\f</code>	<code>\u000C</code>	form feed	<FF>
<code>\r</code>	<code>\u000D</code>	carriage return	<CR>
<code>\"</code>	<code>\u0022</code>	double quote	"
<code>\'</code>	<code>\u0027</code>	single quote	'
<code>\\</code>	<code>\u005C</code>	backslash	\

The CV of *CharacterEscapeSequence* :: *NonEscapeCharacter* is the CV of the *NonEscapeCharacter*.

The CV of *NonEscapeCharacter* :: *SourceCharacter* but not *EscapeCharacter* or *LineTerminator* is the *SourceCharacter* character itself.

The CV of *HexEscapeSequence* :: *x HexDigit HexDigit* is the character whose code point value is (16 times the MV of the first *HexDigit*) plus the MV of the second *HexDigit*.

The CV of *UnicodeEscapeSequence* :: *u HexDigit HexDigit HexDigit HexDigit* is the character whose code point value is (4096 (that is,  $16^3$ ) times the MV of the first *HexDigit*) plus (256 (that is,  $16^2$ ) times the MV of the second *HexDigit*) plus (16 times the MV of the third *HexDigit*) plus the MV of the fourth *HexDigit*.

**NOTE**

A '*LineTerminator*' character cannot appear in a string literal, except when preceded by a backslash \ as a '*LineContinuation*' to produce the empty character sequence. The correct way to cause a line terminator character to be part of the string value of a string literal is to use an escape sequence such as `\n` or `\u000A`.

**7.8.5 Regular Expression Literals**

A regular expression literal is an input element that is converted to a `RegExp` object (section 15.10) each time the literal is evaluated. Two regular expression literals in a program evaluate to regular expression objects that never compare as `===` to each other even if the two literals' contents are identical. A `RegExp` object may also be created at runtime by `new RegExp` (section 15.10.4) or calling the `RegExp` constructor as a function (section 15.10.3).

pratapL 6/30/2008 12:42 PM  
Deleted: even if

pratapL 7/2/2008 11:11 AM  
Deleted: when it is scanned

pratapL 7/4/2008 10:07 AM  
Comment [12]: From AWB: Because of this change `RegExpLiteral` arguably should be moved to section 11.1. However, I am not actually proposing we do so.

pratapL 7/2/2008 11:13 AM  
Deleted: The object is created before evaluation of the containing program or function begins. Evaluation of the literal produces a reference to that object; it does not create a new object.

The productions below describe the syntax for a regular expression literal and are used by the input element scanner to find the end of the regular expression literal. The strings of characters comprising the *RegularExpressionBody* and the *RegularExpressionFlags* are passed uninterpreted to the regular expression constructor, which interprets them according to its own, more stringent grammar. An implementation may extend the regular expression constructor's grammar, but it should not extend the *RegularExpressionBody* and *RegularExpressionFlags* productions or the productions used by these productions.

**Syntax**

*RegularExpressionLiteral* ::  
/ *RegularExpressionBody* / *RegularExpressionFlags*

*RegularExpressionBody* ::  
*RegularExpressionFirstChar* *RegularExpressionChars*

*RegularExpressionChars* ::  
[empty]  
*RegularExpressionChars* *RegularExpressionChar*

*RegularExpressionFirstChar* ::  
*NonTerminator* **but not** \* or \ or /  
*BackslashSequence*

*RegularExpressionChar* ::  
*NonTerminator* **but not** \ or /  
*BackslashSequence*

*BackslashSequence* ::  
\ *NonTerminator*

*NonTerminator* ::  
*SourceCharacter* **but not** *LineTerminator*

*RegularExpressionFlags* ::  
[empty]  
*RegularExpressionFlags* *IdentifierPart*

*NOTE*  
*Regular expression literals may not be empty; instead of representing an empty regular expression literal, the characters // start a single-line comment. To specify an empty regular expression, use /(?:)/.*

**Semantics**

A regular expression literal evaluates to a value of the `RegExp` type. This value is determined in two steps: first, the characters comprising the regular expression's *RegularExpressionBody* and *RegularExpressionFlags* production expansions are collected uninterpreted into two strings `Pattern` and `Flags`, respectively. Then each time the literal is evaluated, a new object is created as if by the expression `new RegExp (Pattern, Flags)` where `RegExp` is the standard built-in constructor with that name. The newly constructed object becomes the value of the `RegularExpressionLiteral`. If the call to `new RegExp` would generate an error, an implementation may, at its discretion, either report the error immediately while scanning the program, or it may defer the error until the regular expression literal is evaluated in the course of program execution.

**7.9 Automatic Semicolon Insertion**

Certain ECMAScript statements (empty statement, variable statement, expression statement, **do-while** statement, **continue** statement, **break** statement, **return** statement, and **throw** statement) must be terminated with semicolons. Such semicolons may always appear explicitly in the source text. For convenience, however, such semicolons may be omitted from the source text in certain situations. These

pratapL 5/27/2008 5:17 PM  
**Deleted:** stands for

pratapL 5/27/2008 5:17 PM  
**Deleted:** Object

pratapL 7/2/2008 11:18 AM  
**Deleted:** constructor is called with two arguments Pattern and Flags and t

pratapL 6/30/2008 3:46 PM  
**Deleted:** result

pratapL 5/27/2008 5:20 PM  
**Deleted:** becomes the value of the *RegularExpressionLiteral*

pratapL 5/27/2008 5:21 PM  
**Deleted:** If

pratapL 7/2/2008 11:20 AM  
**Deleted:** s

pratapL 7/4/2008 10:07 AM  
**Comment [13]:** A proposal to require the scanner to report such errors was rejected because it is likely to break existing web applications. Arguably the change should be made in the opposite direction; the error must not be reported unless the literal is evaluated.

situations are described by saying that semicolons are automatically inserted into the source code token stream in those situations.

### 7.9.1 Rules of Automatic Semicolon Insertion

- When, as the program is parsed from left to right, a token (called the *offending token*) is encountered that is not allowed by any production of the grammar, then a semicolon is automatically inserted before the offending token if one or more of the following conditions is true:
  1. The offending token is separated from the previous token by at least one *LineTerminator*.
  2. The offending token is }.
- When, as the program is parsed from left to right, the end of the input stream of tokens is encountered and the parser is unable to parse the input token stream as a single complete ECMAScript *Program*, then a semicolon is automatically inserted at the end of the input stream.
- When, as the program is parsed from left to right, a token is encountered that is allowed by some production of the grammar, but the production is a *restricted production* and the token would be the first token for a terminal or nonterminal immediately following the annotation “[no *LineTerminator* here]” within the restricted production (and therefore such a token is called a restricted token), and the restricted token is separated from the previous token by at least one *LineTerminator*, then a semicolon is automatically inserted before the restricted token.

However, there is an additional overriding condition on the preceding rules: a semicolon is never inserted automatically if the semicolon would then be parsed as an empty statement or if that semicolon would become one of the two semicolons in the header of a **for** statement (section 12.6.3).

#### NOTE

These are the only restricted productions in the grammar:

*PostfixExpression* :

*LeftHandSideExpression* [no *LineTerminator* here] ++  
*LeftHandSideExpression* [no *LineTerminator* here] --

*ContinueStatement* :

**continue** [no *LineTerminator* here] *Identifier*<sub>opt</sub> ;

*BreakStatement* :

**break** [no *LineTerminator* here] *Identifier*<sub>opt</sub> ;

*ReturnStatement* :

**return** [no *LineTerminator* here] *Expression*<sub>opt</sub> ;

*ThrowStatement* :

**throw** [no *LineTerminator* here] *Expression* ;

The practical effect of these restricted productions is as follows:

- When a ++ or -- token is encountered where the parser would treat it as a postfix operator, and at least one *LineTerminator* occurred between the preceding token and the ++ or -- token, then a semicolon is automatically inserted before the ++ or -- token.
- When a **continue**, **break**, **return**, or **throw** token is encountered and a *LineTerminator* is encountered before the next token, a semicolon is automatically inserted after the **continue**, **break**, **return**, or **throw** token.

The resulting practical advice to ECMAScript programmers is:

- A postfix ++ or -- operator should appear on the same line as its operand.
- An *Expression* in a **return** or **throw** statement should start on the same line as the **return** or **throw** token.
- A label in a **break** or **continue** statement should be on the same line as the **break** or **continue** token.

### 7.9.1.1 Usage Subset *cautious* Restrictions

A Program that contains *cautious* in its set of usage subsets or is evaluated within an execution context that is subset restricted to the *cautious* subset does not perform automatic semicolon insertion. Where the above rules would insert a semicolon, instead a syntax error is detected.

### 7.9.2 Examples of Automatic Semicolon Insertion

The source

```
{ 1 2 } 3
```

is not a valid sentence in the ECMAScript grammar, even with the automatic semicolon insertion rules. In contrast, the source

```
{ 1  
2 } 3
```

is also not a valid ECMAScript sentence, but is transformed by automatic semicolon insertion into the following:

```
{ 1  
;2 ;} 3;
```

which is a valid ECMAScript sentence.

The source

```
for (a; b  
)
```

is not a valid ECMAScript sentence and is not altered by automatic semicolon insertion because the semicolon is needed for the header of a **for** statement. Automatic semicolon insertion never inserts one of the two semicolons in the header of a **for** statement.

The source

```
return  
a + b
```

is transformed by automatic semicolon insertion into the following:

```
return;  
a + b;
```

#### NOTE

The expression **a + b** is not treated as a value to be returned by the **return** statement, because a 'LineTerminator' separates it from the token **return**.

The source

```
a = b  
++c
```

is transformed by automatic semicolon insertion into the following:

```
a = b;  
++c;
```

#### NOTE

The token **++** is not treated as a postfix operator applying to the variable **b**, because a 'LineTerminator' occurs between **b** and **++**.

The source

```
if (a > b)  
else c = d
```

is not a valid ECMAScript sentence and is not altered by automatic semicolon insertion before the **else** token, even though no production of the grammar applies at that point, because an automatically inserted semicolon would then be parsed as an empty statement.

The source

```
a = b + c
(d + e).print()
```

is *not* transformed by automatic semicolon insertion, because the parenthesised expression that begins the second line can be interpreted as an argument list for a function call:

```
a = b + c(d + e).print()
```

In the circumstance that an assignment statement must begin with a left parenthesis, it is a good idea for the programmer to provide an explicit semicolon at the end of the preceding statement rather than to rely on automatic semicolon insertion.

## 8 Types

A value is an entity that takes on one of [eleven](#) types. There are [eleven](#) types (Undefined, Null, Boolean, String, Number, Object, Reference, List, [Completion](#), [Property Descriptor](#), and [Property Identifier](#)). Values of type Reference, List, and Completion are used only as intermediate results of expression evaluation and cannot be stored as properties of objects.

### 8.1 The Undefined Type

The Undefined type has exactly one value, called **undefined**. Any variable that has not been assigned a value has the value **undefined**.

### 8.2 The Null Type

The Null type has exactly one value, called **null**.

### 8.3 The Boolean Type

The Boolean type represents a logical entity having two values, called **true** and **false**.

### 8.4 The String Type

The String type is the set of all finite ordered sequences of zero or more 16-bit unsigned integer values ("elements"). The String type is generally used to represent textual data in a running ECMAScript program, in which case each element in the string is treated as a code point value (see section 6). Each element is regarded as occupying a position within the sequence. These positions are indexed with nonnegative integers. The first element (if any) is at position 0, the next element (if any) at position 1, and so on. The length of a string is the number of elements (i.e., 16-bit values) within it. The empty string has length zero and therefore contains no elements.

When a string contains actual textual data, each element is considered to be a single UTF-16 unit. Whether or not this is the actual storage format of a String, the characters within a String are numbered as though they were represented using UTF-16. All operations on Strings (except as otherwise stated) treat them as sequences of undifferentiated 16-bit unsigned integers; they do not ensure the resulting string is in normalised form, nor do they ensure language-sensitive results.

#### NOTE

The rationale behind these decisions was to keep the implementation of Strings as simple and high-performing as possible. The intent is that textual data coming into the execution environment from outside (e.g., user input, text read from a file or received over the network, etc.) be converted to Unicode Normalised Form C before the running program sees it. Usually this would occur at the same time incoming text is converted from its original character encoding to Unicode (and would impose no additional overhead). Since it is recommended that ECMAScript source code be in Normalised Form C, string literals are guaranteed to be normalised (if source text is guaranteed to be normalised), as long as they do not contain any Unicode escape sequences.

pratapL 7/4/2008 10:08 AM
Deleted: none
pratapL 7/4/2008 10:08 AM
Deleted: none
pratapL 7/4/2008 10:09 AM
Deleted: and

## 8.5 The Number Type

The Number type has exactly  $18437736874454810627$  (that is,  $2^{64}-2^{53}+3$ ) values, representing the double-precision 64-bit format IEEE 754 values as specified in the IEEE Standard for Binary Floating-Point Arithmetic, except that the  $9007199254740990$  (that is,  $2^{53}-2$ ) distinct “Not-a-Number” values of the IEEE Standard are represented in ECMAScript as a single special **NaN** value. (Note that the **NaN** value is produced by the program expression **NaN**, assuming that the globally defined variable **NaN** has not been altered by program execution.) In some implementations, external code might be able to detect a difference between various Non-a-Number values, but such behaviour is implementation-dependent; to ECMAScript code, all NaN values are indistinguishable from each other.

There are two other special values, called **positive Infinity** and **negative Infinity**. For brevity, these values are also referred to for expository purposes by the symbols  $+\infty$  and  $-\infty$ , respectively. (Note that these two infinite number values are produced by the program expressions **+Infinity** (or simply **Infinity**) and **-Infinity**, assuming that the globally defined variable **Infinity** has not been altered by program execution.)

The other  $18437736874454810624$  (that is,  $2^{64}-2^{53}$ ) values are called the finite numbers. Half of these are positive numbers and half are negative numbers; for every finite positive number there is a corresponding negative number having the same magnitude.

Note that there is both a **positive zero** and a **negative zero**. For brevity, these values are also referred to for expository purposes by the symbols  $+0$  and  $-0$ , respectively. (Note that these two zero number values are produced by the program expressions **+0** (or simply **0**) and **-0**.)

The  $18437736874454810622$  (that is,  $2^{64}-2^{53}-2$ ) finite nonzero values are of two kinds:

$18428729675200069632$  (that is,  $2^{64}-2^{54}$ ) of them are normalised, having the form

$$s \times m \times 2^e$$

where  $s$  is  $+1$  or  $-1$ ,  $m$  is a positive integer less than  $2^{53}$  but not less than  $2^{52}$ , and  $e$  is an integer ranging from  $-1074$  to  $971$ , inclusive.

The remaining  $9007199254740990$  (that is,  $2^{53}-2$ ) values are denormalised, having the form

$$s \times m \times 2^e$$

where  $s$  is  $+1$  or  $-1$ ,  $m$  is a positive integer less than  $2^{52}$ , and  $e$  is  $-1074$ .

Note that all the positive and negative integers whose magnitude is no greater than  $2^{53}$  are representable in the Number type (indeed, the integer  $0$  has two representations,  $+0$  and  $-0$ ).

A finite number has an *odd significand* if it is nonzero and the integer  $m$  used to express it (in one of the two forms shown above) is odd. Otherwise, it has an *even significand*.

In this specification, the phrase “the number value for  $x$ ” where  $x$  represents an exact nonzero real mathematical quantity (which might even be an irrational number such as  $\pi$ ) means a number value chosen in the following manner. Consider the set of all finite values of the Number type, with  $-0$  removed and with two additional values added to it that are not representable in the Number type, namely  $2^{1024}$  (which is  $+1 \times 2^{53} \times 2^{971}$ ) and  $-2^{1024}$  (which is  $-1 \times 2^{53} \times 2^{971}$ ). Choose the member of this set that is closest in value to  $x$ . If two values of the set are equally close, then the one with an even significand is chosen; for this purpose, the two extra values  $2^{1024}$  and  $-2^{1024}$  are considered to have even significands. Finally, if  $2^{1024}$  was chosen, replace it with  $+\infty$ ; if  $-2^{1024}$  was chosen, replace it with  $-\infty$ ; if  $+0$  was chosen, replace it with  $-0$  if and only if  $x$  is less than zero; any other chosen value is used unchanged. The result is the number value for  $x$ . (This procedure corresponds exactly to the behaviour of the IEEE 754 “round to nearest” mode.)

Some ECMAScript operators deal only with integers in the range  $-2^{31}$  through  $2^{31}-1$ , inclusive, or in the range  $0$  through  $2^{32}-1$ , inclusive. These operators accept any value of the Number type but first convert each such value to one of  $2^{32}$  integer values. See the descriptions of the `ToInt32` and `ToUint32` operators in sections [9.5](#) and [9.6](#), respectively.

pratapL 7/2/2008 6:26 AM

Deleted: 0

pratapL 7/2/2008 6:26 AM

Deleted: 0



## 8.6 The Object Type

An Object is a collection of properties. Each property is either a named data property, a named procedural property, or an internal property.

- A named data property associates a name with a value and a set of boolean attributes.
- A named procedural property associates a name with a getter method, a setter method, and a set of boolean attributes.
- An internal property has no name and is not directly accessible via the property accessor operators. Internal properties exist purely for specification purposes. How and when some of these properties are used is specified by the language specification below.

pratapL 5/27/2008 5:27 PM  
**Deleted:** an unordered

### 8.6.1 Property Attributes

Attributes are used in this specification to define and explain the state of named properties. A named data property associates a name with the following attributes:

pratapL 5/27/2008 5:31 PM  
**Deleted:** consists of a name, a value and a set of attributes.

**Table 1 Attributes of a Named Data Property**

<i>Attribute Name</i>	<i>Value Domain</i>	<i>Description</i>
[[Value]]	any	The value retrieved by reading the property.
[[Const]]	<b>Uninitialized</b> or <b>Initialized</b>	Used only for the implementation of properties created by a <i>ConstantDeclaration</i> . If present, the value is one of the two symbolic values <b>Uninitialized</b> or <b>Initialized</b> .
[[Writable]]	boolean	If true, attempts by ECMAScript code to assign the property's value will succeed. Otherwise the property is said to be read-only.
[[Enumerable]]	boolean	If true, the property will be enumerated by a for-in enumeration (section 12.6.4). Otherwise, the property is said to be non-enumerable.
[[Flexible]]	boolean	If true, attempts to delete the property or change its attributes will succeed. Otherwise, the property is said to be sealed. See the description of the delete operator in section 11.4.1, and the reflective Object methods. A data property which is both sealed and read-only is frozen.

A named procedural property associates a name with the following attributes:

**Table 2 Attributes of a Named Procedural Property**

<i>Attribute Name</i>	<i>Value Domain</i>	<i>Description</i>
[[Getter]]	function or undefined	A method that to be called each time the property is read, to retrieve the current value of the property.
[[Setter]]	function or undefined	A method to be called each time the property is assigned to, in order to define the current value of the property.
[[Enumerable]]	boolean	If true, the property is to be enumerated by a for-in enumeration (section 12.6.4). Otherwise, the property is said to be non-enumerable.

<a href="#">[[Flexible]]</a>	boolean	If true, attempts to delete the property or change its attributes will succeed. Otherwise, the property is said to be sealed. See the description of the delete operator in section 11.4.1, and the reflective Object methods .
------------------------------	---------	---

If the value of an attribute is not explicitly specified for a named property, the default value as defined in the following table is used:

**Table 3 Default Attribute Values**

Attribute Name	Default Value
<a href="#">[[Value]]</a>	undefined
<a href="#">[[Const]]</a>	Unspecified
<a href="#">[[Getter]]</a>	undefined
<a href="#">[[Setter]]</a>	undefined
<a href="#">[[Writable]]</a>	true
<a href="#">[[Enumerable]]</a>	true
<a href="#">[[Flexible]]</a>	true

Property descriptors, defined in section 8.10, are internal types used within this specification to describe manipulations of property attributes.

### 8.6.2 Internal Properties and Methods

Internal properties and methods are not part of the language. They are defined by this specification purely for expository purposes. An implementation of ECMAScript must behave as if it produced and operated upon internal properties in the manner described here. For the purposes of this document, the names of internal properties are enclosed in double square brackets `[[ ]]`. When an algorithm uses an internal property of an object and the object does not implement the indicated internal property, a **TypeError** exception is thrown.

There are two types of access for normal (non-internal) properties: *get* and *put*, corresponding to retrieval and assignment, respectively.

All ECMAScript objects have an internal property called `[[Prototype]]`. The value of this property is either `null` or an object and is used for implementing inheritance. [Named data properties](#) of the `[[Prototype]]` object [are inherited](#) (are visible as properties of the child object) for the purposes of get access, but not for put access. [Named procedural properties are inherited for both get access and put access.](#)

The following table summarises the internal properties used by this specification [that are applicable to all ECMAScript objects](#). The description indicates their behaviour for all ECMAScript objects, [unless stated otherwise in this document for particular types of ECMAScript objects](#). In particular, [Array objects have a slightly different implementation of the `\[\[ThrowablePut\]\]` method \(see 15.4.5.1\) and \[String objects have a different implementation of the `\\[\\[GetOwnProperty\\]\\]` method\]\(#\). Host objects may implement these internal methods with any implementation-dependent behaviour, or it may be that a host object implements only some internal methods and not others.](#)

pratapL 6/11/2008 12:01 PM  
**Deleted:** A property can have zero or more attributes from the following set: -  
**Description** ... [2]

pratapL 5/27/2008 5:49 PM  
**Deleted:** Native  
 pratapL 5/27/2008 5:53 PM  
**Deleted:** Properties

pratapL 5/27/2008 5:56 PM  
**Deleted:** native

Property	Parameters -> Result	Description
[[Prototype]]	none	The prototype of this object. <a href="#">Must be null or an Object.</a>
[[Class]]	none	A string value indicating the kind of this object.
[[PrimitiveValue]]	none	Internal state information associated with this object.
[[Extensible]]	none	If true, <a href="#">own properties may be added to the object.</a>
[[Get]]	( <i>PropertyName</i> ) -> <i>any</i>	Returns the value of the <a href="#">named</a> property.
[[GetOwnProperty]]	( <i>PropertyName</i> ) -> <i>undefined</i> or <i>Property Descriptor</i>	Returns the <a href="#">Property Descriptor</a> of the <a href="#">named own</a> property of this object, or <a href="#">undefined</a> if absent.
[[GetProperty]]	( <i>PropertyName</i> ) -> <i>undefined</i> or <i>Property Descriptor</i>	Returns the <a href="#">Property Descriptor</a> of the <a href="#">named property</a> of this object, or <a href="#">undefined</a> if absent.
[[Put]]	( <i>PropertyName, Value</i> )	Sets the specified <a href="#">named</a> property to <i>Value</i> .
[[CanPut]]	( <i>PropertyName</i> ) -> <i>boolean</i>	Returns a boolean value indicating whether a [[Put]] operation with <i>PropertyName</i> will succeed.
[[HasProperty]]	( <i>PropertyName</i> ) -> <i>boolean</i>	Returns a boolean value indicating whether the object already has a <a href="#">property</a> with the given name.
[[Delete]]	( <i>PropertyName, Throw</i> ) -> <i>boolean</i>	Removes the specified <a href="#">named own</a> property from the object.
[[DefaultValue]]	( <i>Hint</i> ) -> <i>any</i>	Returns a default value for the object, which should be a primitive value (not an object or reference).
[[DefineOwnProperty]]	( <i>PropertyName, Desc, Throw</i> )	<a href="#">Creates or alters the named own property to have the state described by a Property Descriptor.</a> <i>Throw</i> flag controls failure handling.
[[ThrowablePut]]	( <i>PropertyName, Value, Throw</i> )	<a href="#">Sets the specified named property to Value.</a> <i>Throw</i> flag controls failure handling.
[[Construct]]	(a list of argument values provided by the caller) -> <i>Object</i>	Constructs an object. Invoked via the <b>new</b> operator. Objects that implement this internal method are called <i>constructors</i> .
[[Call]]	(a list of argument values provided by the caller) -> <i>any</i> or <i>nothing</i>	Executes code associated with the object. Invoked via a function call expression. Objects that implement this internal method are called <i>functions</i> .
[[HasInstance]]	( <i>Value</i> ) -> <i>boolean</i>	Returns a boolean value indicating whether <i>Value</i> delegates behaviour to this object. Of the native ECMAScript objects, only Function objects implement [[HasInstance]].
[[Scope]]	<a href="#">none</a>	A scope chain that defines the environment in which a Function object is executed.
[[Match]]	( <i>String, Index</i> ) -> <i>MatchResult</i>	Tests for a regular expression match and returns a <i>MatchResult</i> value (see section 15.10.2.1).

pratapL 6/16/2008 9:34 AM  
Deleted: member

pratapL 7/2/2008 12:10 PM  
Deleted: None

pratapL 6/16/2008 9:39 AM  
Deleted: and

Every object (including host objects) must implement the [[Prototype]], [[Class]], [\[\[Extensible\]\]](#) and [\[\[Identity\]\]](#) internal data properties and the [[Get]], [\[\[GetProperty\]\]](#), [\[\[GetOwnProperty\]\]](#), [\[\[DefineOwnProperty\]\]](#), [[Put]], [[CanPut]], [[HasProperty]], [[Delete]], and [[DefaultValue]] internal methods. (Note, however, that the [[DefaultValue]] method may, for some objects, simply throw a **TypeError** exception.)

The value of the [[Prototype]] property must be either an object or **null**, and every [[Prototype]] chain must have finite length (that is, starting from any object, recursively accessing the [[Prototype]] property must eventually lead to a **null** value). Whether or not a native object can have a host object as its [[Prototype]] depends on the implementation.

The value of the [[Class]] property is defined by this specification for every kind of built-in object. The value of the [[Class]] property of a host object may be any value, even a value used by a built-in object for its [[Class]] property. The value of a [[Class]] property is used internally to distinguish different kinds of built-in objects. Note that this specification does not provide any means for a program to access that value except through **Object.prototype.toString** (see 15.2.4.2).

For native objects the `[[Get]]`, `[[Put]]`, `[[CanPut]]`, `[[HasProperty]]`, `[[Delete]]` and `[[DefaultValue]]` methods behave as described in described in 8.6.2.1, 8.6.2.2, 8.6.2.3, 8.6.2.4, 8.6.2.5 and 8.6.2.6, respectively, except that Array objects have a slightly different implementation of the `[[Put]]` method (see 15.4.5.1). Host objects may implement these methods in any manner unless specified otherwise; for example, one possibility is that `[[Get]]` and `[[Put]]` for a particular host object indeed fetch and store property values but `[[HasProperty]]` always generates **false**.

In the following algorithm descriptions, assume *O* is an ECMAScript object, *P* is a string, *Desc* is an internal property description record, and *Throw* is a boolean flag.

#### 8.6.2.1 `[[Get]]` (P)

When the `[[Get]]` method of *O* is called with property name *P*, the following steps are taken:

1. Call the `[[GetProperty]]` method of *O* with property name *P*.
2. If `Result(1)` is **undefined**, return **undefined**.
3. If `Result(1).[[Const]]` is **Uninitialized** throw a **ReferenceError** exception.
4. If `IsDataDescriptor(Result(1))` is **true**, return `Result(1).[[Value]]`.
5. Otherwise, `IsAccessorDescriptor(Result(1))` must be **true** so, get `Result(1).[[Getter]]`.
6. If `Result(4)` is **undefined**, return **undefined**.
7. Call the `[[Call]]` method of `Result(4)` providing *O* as the **this** value and providing no arguments.
8. Return `Result(6)`.

#### 8.6.2.2 `[[Put]]` (P, V)

`[[Put]]` is primarily used in the specification of built-in methods. Algorithms that require explicit control over the handling of invalid property store should call `[[ThrowablePut]]` directly.

When the `[[Put]]` method of *O* is called with property *P* and value *V*, the following steps are taken:

1. Call the `[[ThrowablePut]]` method of *O* with arguments *P*, *V*, and **false**.
2. Return.

Note, however, that if *O* is an Array object, it has a more elaborate `[[Put]]` method (15.4.5.1).

#### 8.6.2.3 `[[CanPut]]` (P)

The `[[CanPut]]` method is used only by the `[[ThrowablePut]]` method.

When the `[[CanPut]]` method of *O* is called with property name *P*, the following steps are taken:

1. Call the `[[GetOwnProperty]]` method of *O* with argument *P*.
2. If `Result(1)` is not **undefined**, then
  - a. If `IsDataDescriptor(Result(1))` is **true**, return the value of `Result(1).[[Writable]]`.
  - b. If `IsAccessorDescriptor(Result(1))` is **true**, return **true**.
  - c. If the `[[Extensible]]` property of *O* is **false**, return **false**.
3. Get the internal `[[Prototype]]` property of *O*.
4. If `Result(3)` is **null**, then return **true**.
5. Call the `[[GetProperty]]` method of `Result(3)` with property name *P*.
6. If `Result(5)` is **undefined**, return **true**.
7. If `IsDataDescriptor(Result(5))` is **true** return the value of `Result(5).[[Writable]]`.
8. Return **true**.

#### 8.6.2.4 `[[HasProperty]]` (P)

When the `[[HasProperty]]` method of *O* is called with property name *P*, the following steps are taken:

1. Call the `[[GetProperty]]` method of *O* with property name *P*.
2. If `Result(1)` is **undefined**, then return **false**.
3. Else return **true**.

#### 8.6.2.5 `[[Delete]]` (P, Throw)

When the `[[Delete]]` method of *O* is called with property name *P* and the boolean flag *Throw*, the following steps are taken:

1. Call the `[[GetOwnProperty]]` method of *O* with property name *P*.
2. If `Result(1)` is **undefined**, then return **true**.
3. If `Result(1).[[Flexible]]` is **true**, then

pratapL 5/27/2008 6:19 PM  
Deleted: a native  
pratapL 5/27/2008 6:19 PM  
Deleted: and

pratapL 5/27/2008 6:57 PM  
Deleted: If *O* doesn't have a property with name *P*, go to step 4. ... [3]

pratapL 5/27/2008 7:08 PM  
Deleted: <#>Call the `[[CanPut]]` method of *O* with name *P*. ... [4]

pratapL 6/30/2008 5:15 PM  
Deleted: If *O* doesn't have a property with name *P*, go to step 4. ... [5]

pratapL 5/28/2008 10:19 PM  
Deleted: If *O* has a property with name *P*, return **true**. ... [6]

pratapL 5/28/2008 10:29 PM  
Deleted: ... [7]

- a. [Remove the own property with name \*P\* from \*O\*.](#)
- b. [Return \*\*true\*\*.](#)
4. [Else if \*Throw\*, then throw a \*\*TypeError\*\* exception.](#)
5. [Return \*\*false\*\*.](#)

#### 8.6.2.6 **[[DefaultValue]] (hint)**

When the **[[DefaultValue]]** method of *O* is called with hint String, the following steps are taken:

1. Call the **[[Get]]** method of object *O* with argument "**toString**".
2. If Result(1) is not an object, go to step 5.
3. Call the **[[Call]]** method of Result(1), with *O* as the **this** value and an empty argument list.
4. If Result(3) is a primitive value, return Result(3).
5. Call the **[[Get]]** method of object *O* with argument "**valueOf**".
6. If Result(5) is not an object, go to step 9.
7. Call the **[[Call]]** method of Result(5), with *O* as the **this** value and an empty argument list.
8. If Result(7) is a primitive value, return Result(7).
9. Throw a **TypeError** exception.

When the **[[DefaultValue]]** method of *O* is called with hint Number, the following steps are taken:

1. Call the **[[Get]]** method of object *O* with argument "**valueOf**".
2. If Result(1) is not an object, go to step 5.
3. Call the **[[Call]]** method of Result(1), with *O* as the **this** value and an empty argument list.
4. If Result(3) is a primitive value, return Result(3).
5. Call the **[[Get]]** method of object *O* with argument "**toString**".
6. If Result(5) is not an object, go to step 9.
7. Call the **[[Call]]** method of Result(5), with *O* as the **this** value and an empty argument list.
8. If Result(7) is a primitive value, return Result(7).
9. Throw a **TypeError** exception.

When the **[[DefaultValue]]** method of *O* is called with no hint, then it behaves as if the hint were Number, unless *O* is a Date object (see 15.9), in which case it behaves as if the hint were String.

The above specification of **[[DefaultValue]]** for native objects can return only primitive values. If a host object implements its own **[[DefaultValue]]** method, it must ensure that its **[[DefaultValue]]** method can return only primitive values.

#### 8.6.2.7 **[[GetProperty]] (P)**

[When the \*\*\[\[GetProperty\]\]\*\* method of \*O\* is called with property name \*P\*, the following steps are taken:](#)

1. [Call the \*\*\[\[GetOwnProperty\]\]\*\* method of \*O\* with property name \*P\*.](#)
2. [If Result\(1\) is not \*\*undefined\*\*, return Result\(1\).](#)
3. [If the \*\*\[\[Prototype\]\]\*\* of \*O\* is \*\*null\*\*, return \*\*undefined\*\*.](#)
4. [Call the \*\*\[\[GetProperty\]\]\*\* method of \*\*\[\[Prototype\]\]\*\* with property name \*P\*.](#)
5. [Return Result\(4\).](#)

#### 8.6.2.8 **[[GetOwnProperty]] (P)**

[When the \*\*\[\[GetOwnProperty\]\]\*\* method of \*O\* is called with property name \*P\*, the following steps are taken:](#)

1. [If \*O\* doesn't have an own property with name \*P\*, return \*\*undefined\*\*.](#)
2. [Otherwise \*O\* has an own property with name \*P\*, so return a Property Descriptor describing its current attribute state.](#)

[Note, however, that if \*O\* is a String object it has a more elaborate \*\*\[\[GetOwnProperty\]\]\*\* method \(15.5.5.2\).](#)

#### 8.6.2.9 **[[DefineOwnProperty]] (P, Desc, Throw)**

[In the following algorithm, the term "Reject" means "If \*Throw\* is \*\*true\*\*, then throw a \*\*TypeError\*\* exception, otherwise return."](#)

[When the \*\*\[\[DefineOwnProperty\]\]\*\* method of \*O\* is called with property name \*P\*, property descriptor \*Desc\*, and boolean flag \*Throw\*, the following steps are taken:](#)

1. Call the `[[GetOwnProperty]]` method of *O* with property name *P*.
2. Get the `[[Extensible]]` internal property of *O*.
3. If `Result(1)` is **undefined** and `Result(2)` is **true**, then
  - a. If `IsGenericDescriptor(Desc)` or `IsDataDescriptor(Desc)` is **true**, then
    - i. Create an own data property named *P* of object *O* whose state is that described by *Desc*. If the value of an attribute field of *Desc* is the value **Unspecified**, the corresponding attribute of the newly created property gets its default value. If the *Desc* includes a `[[Const]]` attribute whose value is **Unspecified**, do not create a `[[Const]]` attribute for the property.
  - b. Else, *Desc* must be an accessor property descriptor so,
    - i. Create an own accessor property named *P* of object *O* whose state is that described by *Desc*. If the value of an attribute field of *Desc* is the value **Unspecified**, the corresponding attribute of the newly created property gets its default value.
  - c. Return.
4. Else If `Result(1)` is **undefined** and `Result(2)` is **false**, then **Reject**.
5. Return, if the value of every field in *Desc* is either **Unspecified** or is the same value as the corresponding field in `Result(1)`.
6. If `Desc. [[Const]]` is not **Unspecified**, then
  - a. **Reject**, if `Result(1). [[Const]]` is **Unspecified** because `[[Const]]` must be specified when a `Const` property is created.
  - b. **Reject**, if `Result(1). [[Const]]` is **Initialized** and `Desc. [[Const]]` is **Uninitialized** because `[[Const]]` cannot make that state transition.
7. If the `[[Flexible]]` field of `Result(1)` is **false** then
  - a. **Reject**, if the `[[Flexible]]` field of *Desc* is **true**.
  - b. **Reject**, if the `[[Enumerable]]` field of `Result(1)` and *Desc* are the Boolean negation of each other.
8. If `IsGenericDescriptor(Desc)` is **true**, then no further validation is required.
9. Else, if `IsDataDescriptor(Result(1))` and `IsDataDescriptor(Desc)` have different results, then
  - a. **Reject**, if the `[[Flexible]]` field of `Result(1)` is **false**.
  - b. If `IsDataDescriptor(Result(1))` is **true**, then
    - i. Convert the property named *P* of object *O* to from a data property to an accessor property. Preserve the existing values of the converted property's `[[Flexible]]` and `[[Enumerable]]` attributes and set the the rest of the property's attributes to their default values.
  - c. Else,
    - i. Convert the property named *P* of object *O* to from an accessor property to a data property. Preserve the existing values of the converted property's `[[Flexible]]` and `[[Enumerable]]` attributes and set the the rest of the property's attributes to their default values.
10. Else, if `IsDataDescriptor(Result(1))` and `IsDataDescriptor(Desc)` are both **true**, then
  - a. If the `[[Flexible]]` field of `Result(1)` is **false**, then
    - i. **Reject**, if the `[[Writable]]` field of `Result(1)` is **false** and the `[[Writable]]` field of *Desc* is **true**.
    - ii. If the `[[Writable]]` field of `Result(1)` is **false**, then
      1. **Reject**, if the `[[Value]]` field of *Desc* is not **Unspecified** and is a different value than the `[[Value]]` field of `Result(1)`.
  - b. else, the `[[Flexible]]` field of `Result(1)` is **true**, so
    - i. If the `[[Writable]]` field of `Result(1)` is **false** and the `[[Writable]]` field of *Desc* is either **Unspecified** or **false**, then
      1. **Reject**, if the `[[Value]]` field of *Desc* is not **Unspecified** and is a different value than the `[[Value]]` field of `Result(1)`.
11. Else, `IsAccessorDescriptor(Result(1))` and `IsAccessorDescriptor(Desc)` are both **true** so,
  - a. If the `[[Flexible]]` field of `Result(1)` is **false**, then
    - i. **Reject**, if the `[[Setter]]` field of *Desc* is not **Unspecified** and is a different value than the `[[Setter]]` field of `Result(1)`.
    - ii. **Reject**, if the `[[Getter]]` field of *Desc* is not **Unspecified** and is a different value than the `[[Getter]]` field of `Result(1)`.

- 12. For each attribute field of *Desc* that does not have the value **Unspecified**, set the correspondingly named attribute of the property named *P* of object *O* to the value of the field.
- 13. Return.

**8.6.2.10** **[[ThrowablePut]] ( P, V, Throw )**

When the **[[ThrowablePut]]** method of *O* is called with property *P*, value *V*, and boolean flag *Throw* the following steps are taken:

- 1. Call the **[[GetOwnProperty]]** method of *O* with argument *P*.
- 2. If result(1) is not **undefined**, then
  - a. If Result(1).**[[Const]]** is not **Unspecified**, then throw a **ReferenceError** exception.
- 3. Call the **[[CanPut]]** method of *O* with argument *P*.
- 4. If Result(3) is **false**, then
  - a. If *Throw* is **true**, then throw a **TypeError** exception.
  - b. Else return.
- 5. Call the **[[GetOwnProperty]]** method of *O* with name *P*.
- 6. If **IsDataDescriptor**(Result(5)) is **true**, then
  - a. Set the **[[Value]]** attribute of property *P* of *O* to *V*.
  - b. Return **true**.
- 7. Call the **[[GetProperty]]** method of *O* with argument *P*.
- 8. If **IsAccessorDescriptor**(Result(5)) is **true**, then
  - a. Get Result(5).**[[Setter]]**.
  - b. If Result(8a) is not **undefined**, then
    - i. Call the **[[Call]]** method of Result(8a) providing *O* as the **this** value and providing *V* as the sole argument.
  - c. Return.
- 9. Create a named data property *P* on object *O* whose attributes are:
  - a. **[[Value]]**: *V*.
  - b. **[[Writable]]**: **true**.
  - c. **[[Enumerable]]**: **true**.
  - d. **[[Flexible]]**: **true**.
- 10. Return.

Note, however, that if *O* is an Array object, it has a more elaborate **[[ThrowablePut]]** method (15.4.5.1).

**8.7** **The Reference Type**

*The internal Reference type is not a language data type.* It is defined by this specification purely for expository purposes. An implementation of ECMAScript must behave as if it produced and operated upon references in the manner described here. However, a value of type **Reference** is used only as an intermediate result of expression evaluation and cannot be stored as the value of a variable or property.

The Reference type is used to explain the behaviour of such operators as **delete**, **typeof**, and the assignment operators. For example, the left-hand operand of an assignment is expected to produce a reference. The behaviour of assignment could, instead, be explained entirely in terms of a case analysis on the syntactic form of the left-hand operand of an assignment operator, but for one difficulty: function calls are permitted to return references. [This possibility is admitted purely for the sake of host objects.] Another reason not to use a syntactic case analysis is that it would be lengthy and awkward, affecting many parts of the specification.

Another use of the Reference type is to explain the determination of the **this** value for a function call.

A **Reference** is a reference to a property of an object. A Reference consists of two components, the *base object* and the *property name*.

The following abstract operations are used in this specification to access the components of references:

- **GetBase(V)**. Returns the base object component of the reference *V*.
- **GetPropertyname(V)**. Returns the property name component of the reference *V*.

The following abstract operations are used in this specification to operate on references:

pratapL 6/30/2008 6:21 PM  
Deleted: -

pratapL 7/4/2008 10:07 AM  
**Comment [14]:** We wanted to remove this , but have decided to leave it in as this could potentially break web applications.

pratapL 5/28/2008 10:32 PM  
**Deleted:** No built-in ECMAScript function defined by this specification returns a reference and there is no provision for a user-defined function to return a reference. (

pratapL 5/28/2008 10:34 PM  
**Deleted:** )

### 8.7.1 GetValue (V)

1. If Type(*V*) is not Reference, return *V*.
2. Call GetBase(*V*).
3. If Result(2) is **null**, throw a **ReferenceError** exception.
4. Call the `[[Get]]` method of Result(2), passing GetPropertyName(*V*) for the property name.
5. Return Result(4).

### 8.7.2 PutValue (V, W, Throw)

1. If Type(*V*) is not Reference, throw a **ReferenceError** exception.
2. Call GetBase(*V*).
3. If Result(2) is **null**, then
  - a. If *Throw* is **true**, then throw a **ReferenceError** exception.
  - b. Call the `[[ThrowablePut]]` method for the global object, passing GetPropertyName(*V*) for the property name, *W* for the value, and **false** for the *Throw* flag.
  - c. Return
4. Else
  - a. Call the `[[ThrowablePut]]` method of Result(2), passing GetPropertyName(*V*) for the property name, *W* for the value, and *Throw* for the *Throw* flag.
  - b. Return.

## 8.8 The List Type

*The internal List type is not a language data type.* It is defined by this specification purely for expository purposes. An implementation of ECMAScript must behave as if it produced and operated upon List values in the manner described here. However, a value of the List type is used only as an intermediate result of expression evaluation and cannot be stored as the value of a variable or property.

The List type is used to explain the evaluation of argument lists (see 11.2.4) in **new** expressions and in function calls. Values of the List type are simply ordered sequences of values. These sequences may be of any length.

## 8.9 The Completion Type

*The internal Completion type is not a language data type.* It is defined by this specification purely for expository purposes. An implementation of ECMAScript must behave as if it produced and operated upon Completion values in the manner described here. However, a value of the Completion type is used only as an intermediate result of statement evaluation and cannot be stored as the value of a variable or property.

The Completion type is used to explain the behaviour of statements (**break**, **continue**, **return** and **throw**) that perform nonlocal transfers of control. Values of the Completion type are triples of the form (*type*, *value*, *target*), where *type* is one of **normal**, **break**, **continue**, **return**, or **throw**, *value* is any ECMAScript value or **empty**, and *target* is any ECMAScript identifier or **empty**.

The term “abrupt completion” refers to any completion with a type other than **normal**.

## 8.10 The Property Descriptor and Property Identifier Types

*The internal Property Descriptor and Property Identifier types are not language data types. They are defined by this specification purely for expository purposes. An implementation of ECMAScript must behave as if it produced and operated upon Property Descriptor and Property Identifier values in the manner described here. However, values of these types are used only as an intermediate result of expression evaluation and cannot be stored as the value of a variable or property.*

*The Property Descriptor type is used to explain the manipulation and reification of named property attributes. Values of the Property Descriptor type are records composed of named fields where each field's name is an attribute name and its value is a corresponding attribute value. In addition, any field may have the value Unspecified. Unspecified is a unique distinguished value that is only used for specification purposes in conjunction with property descriptor fields. It cannot be stored as the value of a variable or property.*

*Property Descriptor values may be further classified as data property descriptors and accessor property descriptors based upon the existence or use of certain fields. A data property descriptor is one that includes any fields named either `[[Value]]`, or `[[Writable]]` and at least one of the those fields has a value other than Unspecified. A accessor property descriptor is one that includes any fields named either `[[Getter]]`, or*

pratapL 6/30/2008 6:40 PM

**Deleted:** <#>If Type(*V*) is not Reference, throw a **ReferenceError** exception. -

... [8]



[[Setter]] and at least one of the those fields has a value other than **Unspecified**. Any property descriptor may have fields named [[Enumerable]], and [[Flexible]]. The domain of values for each field is the possible values of the correspondingly named attribute and the value **Unspecified**.

For notational convenience within this specification, an object literal-like syntax can be used to define a property descriptor value. For example, `Property Descriptor{[[Value]]: 42, [[Writable]]: false, [[Flexible]]: true}` defines a data property descriptor. The order of listing fields names is not significant and any fields that are not explicitly listed have the value **Unspecified**.

In specification text and algorithms, dot notation may be used to refer to a specific field of a Property Descriptor. For example, if *D* is a property descriptor then *D*.[[Value]] is short hand for “the field of *D* named [[Value]]”.

The Property Identifier type is used to associate a property name with a Property Descriptor. Values of the Property Identifier type are pairs of the form (name, descriptor), where name is a string and descriptor is a Property Descriptor value.

The following abstract operations are used in this specification to operate upon Property Descriptor values:

#### **8.10.1 IsValidDescriptor ( Desc )**

When the internal `IsValidDescriptor` function is called with property descriptor *Desc* the following steps are taken:

1. If *Desc* is **undefined**, then return **false**.
2. If either *Desc*.[[Getter]] and *Desc*.[[Setter]] have a value other than **Unspecified**, then
  - a. If either *Desc*.[[Value]] and *Desc*.[[Writable]] have a value other than **Unspecified**, then return **false**.
3. Return **true**.

#### **8.10.2 IsAccessorDescriptor ( Desc )**

When the internal `IsAccessorDescriptor` function is called with property descriptor *Desc* the following steps are taken:

1. If *Desc* is **undefined**, then return **false**.
2. If `IsValidDescriptor(Desc)` is **false**, then return **false**.
3. If *Desc*.[[Getter]] and *Desc*.[[Setter]] both have the value **Unspecified**, then return **false**.
4. Return **true**.

#### **8.10.3 IsDataDescriptor ( Desc )**

When the internal `IsDataDescriptor` function is called with property descriptor *Desc* the following steps are taken:

1. If *Desc* is **undefined**, then return **false**.
2. If `IsValidDescriptor(Desc)` is **false**, then return **false**.
3. If *Desc*.[[Value]] and *Desc*.[[Writable]] both have the value **Unspecified**, then return **false**.
4. Return **true**.

#### **8.10.4 IsGenericDescriptor ( Desc )**

When the internal `IsGenericDescriptor` function is called with property descriptor *Desc* the following steps are taken:

1. If *Desc* is **undefined**, then return **false**.
2. If `IsValidDescriptor(Desc)` is **false**, then return **false**.
3. If calling `IsAccessorDescriptor(Desc)` and `IsDataDescriptor(Desc)` both return **false**, then return **true**.
4. Return **false**.

#### **8.10.5 FromPropertyDescriptor ( Desc )**

When the internal `FromPropertyDescriptor` function is called with property descriptor *Desc* the following steps are taken: the following steps are taken:

1. If *Desc* is **undefined**, then return **false**.
2. Create a new object as if by the expression `new Object()` where `Object` is the standard built-in constructor with that name.
3. If `IsDataDescriptor(Desc)` is true, then

- a. If the value of *Desc*.[[Value]] is not **Unspecified** then
    - i. Call the [[Put]] method of Result(2) with arguments “value” and *Desc*.[[Value]].
  - b. Else, Call the [[Put]] method of Result(2) with arguments “value” and **undefined**.
  - c. If the value of *Desc*.[[Writable]] is not **Unspecified** then
    - i. Call the [[Put]] method of Result(2) with arguments “writable” and *Desc*.[[Value]].
  - d. Else, Call the [[Put]] method of Result(2) with arguments “writable” and **false**.
4. If *IsAccessorDescriptor*(*Desc*) is true, then
    - a. If the value of *Desc*.[[Getter]] is not **Unspecified** then
      - i. Call the [[Put]] method of Result(2) with arguments “getter” and *Desc*.[[Value]].
    - b. Else, Call the [[Put]] method of Result(2) with arguments “getter” and **undefined**.
    - c. If the value of *Desc*.[[Setter]] is not **Unspecified** then
      - i. Call the [[Put]] method of Result(2) with arguments “setter” and *Desc*.[[Value]].
    - d. Else, Call the [[Put]] method of Result(2) with arguments “setter” and **undefined**.
  5. If the value of *Desc*.[[Enumerable]] is not **Unspecified** then
    - a. Call the [[Put]] method of Result(2) with arguments “enumerable” and *Desc*.[[Value]].
  6. Else, Call the [[Put]] method of Result(2) with arguments “enumerable” and **false**.
  7. If the value of *Desc*.[[Flexible]] is not **Unspecified** then
    - a. Call the [[Put]] method of Result(2) with arguments “flexible” and *Desc*.[[Value]].
  8. the [[Put]] method of Result(2) with arguments “enumerable” and **false**.
  9. Return Result(2).

#### 8.10.6 ToPropertyDescriptor ( DescObj )

When the internal ToPropertyDescriptor function is called with object *DescObj*, the following steps are taken:

1. If *Desc* is **undefined**, then return **undefined**.
2. Call ToObject(*DescObj*).
3. Create a new Property Descriptor all of whose fields have the value **Unspecified**.
4. Call the [[HasProperty]] method of Result(2) with argument “enumerable”.
5. If Result(4) is true, then
  - a. Call the [[Get]] method of *DescObj* with “enumerable”.
  - b. Call ToBoolean(Result(5a)).
  - c. Set the [[Enumerable]] field of Result(3) to Result(5b).
6. Call the [[HasProperty]] method of Result(2) with argument “flexible”.
7. If Result(6) is true, then
  - a. Call the [[Get]] method of Result(2) with argument “flexible”.
  - b. Call ToBoolean(Result(7a)).
  - c. Set the [[Flexible]] field of Result(3) to Result(7b).
8. Call the [[HasProperty]] method of Result(2) with argument “value”.
9. If Result(8) is true, then
  - a. Call the [[Get]] method of Result(2) with argument “value”.
  - b. Set the [[Value]] field of Result(3) to Result(9b).
10. Call the [[HasProperty]] method of Result(2) with argument “writable”.
11. If Result(10) is true, then
  - a. Call the [[Get]] method of Result(2) with argument “writable”.
  - b. Call ToBoolean(Result(11a)).
  - c. Set the [[Writable]] field of Result(3) to Result(11b).
12. Call the [[HasProperty]] method of Result(2) with argument “getter”.
13. If Result(12) is true, then
  - a. Call the [[Get]] method of Result(2) with argument “getter”.
  - b. Call IsCallable(Result(13a)).
  - c. If Result(13b) is **false** and Result(13a) is not **undefined**, then throw a **TypeError** exception.
  - d. Set the [[Getter]] field of Result(3) to Result(13b).
14. Call the [[HasProperty]] method of Result(2) with argument “setter”.
15. If Result(10) is true, then
  - a. Call the [[Get]] method of Result(2) with argument “setter”.
  - b. Call IsCallable(Result(15a)).
  - c. If Result(15b) is **false** and Result(15a) is not **undefined**, then throw a **TypeError** exception.
  - d. Set the [[Setter]] field of Result(3) to Result(15b).

- 16. [Call IsValidDescriptor\(Result\(3\)\).](#)
- 17. [If Result\(16\) is false, then throw a \*\*TypeError\*\* exception.](#)
- 18. [Return Result\(3\).](#)

## 9 Type Conversion and Testing

The ECMAScript runtime system performs automatic type conversion as needed. To clarify the semantics of certain constructs it is useful to define a set of conversion operators. These operators are not a part of the language; they are defined here to aid the specification of the semantics of the language. The conversion operators are polymorphic; that is, they can accept a value of any standard type, but not of type Reference, List, Completion, or PropertyDescriptor (the internal types).

pratapL 5/28/2008 10:40 PM  
Deleted: or

### 9.1 ToPrimitive

The operator ToPrimitive takes a Value argument and an optional argument PreferredType. The operator ToPrimitive converts its value argument to a non-Object type. If an object is capable of converting to more than one primitive type, it may use the optional hint PreferredType to favour that type. Conversion occurs according to the following table:

Input Type	Result
Undefined	The result equals the input argument (no conversion).
Null	The result equals the input argument (no conversion).
Boolean	The result equals the input argument (no conversion).
Number	The result equals the input argument (no conversion).
String	The result equals the input argument (no conversion).
Object	Return a default value for the Object. The default value of an object is retrieved by calling the internal <code>[[DefaultValue]]</code> method of the object, passing the optional hint PreferredType. The behaviour of the <code>[[DefaultValue]]</code> method is defined by this specification for all native ECMAScript objects (8.6.2.6).

### 9.2 ToBoolean

The operator ToBoolean converts its argument to a value of type Boolean according to the following table:

Input Type	Result
Undefined	<b>false</b>
Null	<b>false</b>
Boolean	The result equals the input argument (no conversion).
Number	The result is <b>false</b> if the argument is <b>+0</b> , <b>-0</b> , or <b>NaN</b> ; otherwise the result is <b>true</b> .
String	The result is <b>false</b> if the argument is the empty string (its length is zero); otherwise the result is <b>true</b> .
Object	<b>true</b>

### 9.3 ToNumber

The operator ToNumber converts its argument to a value of type Number according to the following table:

Input Type	Result
------------	--------

Undefined	<b>NaN</b>
Null	<b>+0</b>
Boolean	The result is <b>1</b> if the argument is <b>true</b> . The result is <b>+0</b> if the argument is <b>false</b> .
Number	The result equals the input argument (no conversion).
String	See grammar and note below.
Object	Apply the following steps: 1. Call ToPrimitive(input argument, hint Number). 2. Call ToNumber(Result(1)). 3. Return Result(2).

### 9.3.1 ToNumber Applied to the String Type

ToNumber applied to strings applies the following grammar to the input string. If the grammar cannot interpret the string as an expansion of *StringNumericLiteral*, then the result of ToNumber is NaN.

*StringNumericLiteral* :::  
    *StrWhiteSpace*<sub>opt</sub>  
    *StrWhiteSpace*<sub>opt</sub> *StrNumericLiteral* *StrWhiteSpace*<sub>opt</sub>

*StrWhiteSpace* :::  
    *StrWhiteSpaceChar* *StrWhiteSpace*<sub>opt</sub>

*StrWhiteSpaceChar* :::  
    [WhiteSpace](#)  
    [LineTerminator](#)

*StrNumericLiteral* :::  
    *StrDecimalLiteral*  
    *HexIntegerLiteral*

*StrDecimalLiteral* :::  
    *StrUnsignedDecimalLiteral*  
    + *StrUnsignedDecimalLiteral*  
    - *StrUnsignedDecimalLiteral*

*StrUnsignedDecimalLiteral* :::  
    **Infinity**  
    *DecimalDigits* . *DecimalDigits*<sub>opt</sub> *ExponentPart*<sub>opt</sub>  
    . *DecimalDigits* *ExponentPart*<sub>opt</sub>  
    *DecimalDigits* *ExponentPart*<sub>opt</sub>

*DecimalDigits* :::  
    *DecimalDigit*  
    *DecimalDigits* *DecimalDigit*

*DecimalDigit* ::: one of  
    0 1 2 3 4 5 6 7 8 9

*ExponentPart* :::  
    *ExponentIndicator* *SignedInteger*

*ExponentIndicator* ::: one of  
    e E

pratapL 7/2/2008 5:33 AM  
**Deleted:** <TAB> ..  
<SP> ..  
<NBSP> ..  
<FF> ..  
<VT> ..  
<CR> ..  
<LF> ..  
<LS> ..  
<PS> ..

pratapL 7/2/2008 5:33 AM  
**Deleted:** <USP>

*SignedInteger* :::  
*DecimalDigits*  
+ *DecimalDigits*  
- *DecimalDigits*

*HexIntegerLiteral* :::  
0x *HexDigit*  
0X *HexDigit*  
*HexIntegerLiteral* *HexDigit*

*HexDigit* ::: one of  
0 1 2 3 4 5 6 7 8 9 a b c d e f A B C D E F

Some differences should be noted between the syntax of a *StringNumericLiteral* and a *NumericLiteral* (see 7.8.3):

- A *StringNumericLiteral* may be preceded and/or followed by white space and/or line terminators.
- A *StringNumericLiteral* that is decimal may have any number of leading 0 digits.
- A *StringNumericLiteral* that is decimal may be preceded by + or - to indicate its sign.
- A *StringNumericLiteral* that is empty or contains only white space is converted to +0.

The conversion of a string to a number value is similar overall to the determination of the number value for a numeric literal (see 7.8.3), but some of the details are different, so the process for converting a string numeric literal to a value of Number type is given here in full. This value is determined in two steps: first, a mathematical value (MV) is derived from the string numeric literal; second, this mathematical value is rounded as described below.

- The MV of *StringNumericLiteral* ::: [empty] is 0.
- The MV of *StringNumericLiteral* ::: *StrWhiteSpace* is 0.
- The MV of *StringNumericLiteral* ::: *StrWhiteSpace*<sub>opt</sub> *StrNumericLiteral* *StrWhiteSpace*<sub>opt</sub> is the MV of *StrNumericLiteral*, no matter whether white space is present or not.
- The MV of *StrNumericLiteral* ::: *StrDecimalLiteral* is the MV of *StrDecimalLiteral*.
- The MV of *StrNumericLiteral* ::: *HexIntegerLiteral* is the MV of *HexIntegerLiteral*.
- The MV of *StrDecimalLiteral* ::: *StrUnsignedDecimalLiteral* is the MV of *StrUnsignedDecimalLiteral*.
- The MV of *StrDecimalLiteral*::: + *StrUnsignedDecimalLiteral* is the MV of *StrUnsignedDecimalLiteral*.
- The MV of *StrDecimalLiteral*::: - *StrUnsignedDecimalLiteral* is the negative of the MV of *StrUnsignedDecimalLiteral*. (Note that if the MV of *StrUnsignedDecimalLiteral* is 0, the negative of this MV is also 0. The rounding rule described below handles the conversion of this sign less mathematical zero to a floating-point +0 or -0 as appropriate.)
- The MV of *StrUnsignedDecimalLiteral*::: **Infinity** is 10<sup>10000</sup> (a value so large that it will round to +∞).
- The MV of *StrUnsignedDecimalLiteral*::: *DecimalDigits* . is the MV of *DecimalDigits*.
- The MV of *StrUnsignedDecimalLiteral*::: *DecimalDigits* . *DecimalDigits* is the MV of the first *DecimalDigits* plus (the MV of the second *DecimalDigits* times 10<sup>n</sup>), where n is the number of characters in the second *DecimalDigits*.

The MV of *StrUnsignedDecimalLiteral*::: *DecimalDigits* . *ExponentPart* is the MV of *DecimalDigits* times 10<sup>e</sup>, where e is the MV of *ExponentPart*.

The MV of *StrUnsignedDecimalLiteral*::: *DecimalDigits* . *DecimalDigits* *ExponentPart* is (the MV of the first *DecimalDigits* plus (the MV of the second *DecimalDigits* times 10<sup>n</sup>)) times 10<sup>e</sup>, where n is the number of characters in the second *DecimalDigits* and e is the MV of *ExponentPart*.

The MV of *StrUnsignedDecimalLiteral*::: . *DecimalDigits* is the MV of *DecimalDigits* times 10<sup>n</sup>, where n is the number of characters in *DecimalDigits*.

The MV of *StrUnsignedDecimalLiteral*::: . *DecimalDigits* *ExponentPart* is the MV of *DecimalDigits* times 10<sup>e-n</sup>, where n is the number of characters in *DecimalDigits* and e is the MV of *ExponentPart*.

The MV of *StrUnsignedDecimalLiteral*::: *DecimalDigits* is the MV of *DecimalDigits*.

The MV of *StrUnsignedDecimalLiteral*::: *DecimalDigits ExponentPart* is the MV of *DecimalDigits* times  $10^e$ , where  $e$  is the MV of *ExponentPart*.

The MV of *DecimalDigits* ::: *DecimalDigit* is the MV of *DecimalDigit*.

The MV of *DecimalDigits* ::: *DecimalDigits DecimalDigit* is (the MV of *DecimalDigits* times 10) plus the MV of *DecimalDigit*.

The MV of *ExponentPart* ::: *ExponentIndicator SignedInteger* is the MV of *SignedInteger*.

The MV of *SignedInteger* ::: *DecimalDigits* is the MV of *DecimalDigits*.

The MV of *SignedInteger* ::: + *DecimalDigits* is the MV of *DecimalDigits*.

The MV of *SignedInteger* ::: - *DecimalDigits* is the negative of the MV of *DecimalDigits*.

The MV of *DecimalDigit* ::: 0 or of *HexDigit* ::: 0 is 0.

The MV of *DecimalDigit* ::: 1 or of *HexDigit* ::: 1 is 1.

The MV of *DecimalDigit* ::: 2 or of *HexDigit* ::: 2 is 2.

The MV of *DecimalDigit* ::: 3 or of *HexDigit* ::: 3 is 3.

The MV of *DecimalDigit* ::: 4 or of *HexDigit* ::: 4 is 4.

The MV of *DecimalDigit* ::: 5 or of *HexDigit* ::: 5 is 5.

The MV of *DecimalDigit* ::: 6 or of *HexDigit* ::: 6 is 6.

The MV of *DecimalDigit* ::: 7 or of *HexDigit* ::: 7 is 7.

The MV of *DecimalDigit* ::: 8 or of *HexDigit* ::: 8 is 8.

The MV of *DecimalDigit* ::: 9 or of *HexDigit* ::: 9 is 9.

The MV of *HexDigit* ::: a or of *HexDigit* ::: A is 10.

The MV of *HexDigit* ::: b or of *HexDigit* ::: B is 11.

The MV of *HexDigit* ::: c or of *HexDigit* ::: C is 12.

The MV of *HexDigit* ::: d or of *HexDigit* ::: D is 13.

The MV of *HexDigit* ::: e or of *HexDigit* ::: E is 14.

The MV of *HexDigit* ::: f or of *HexDigit* ::: F is 15.

The MV of *HexIntegerLiteral* ::: 0x *HexDigit* is the MV of *HexDigit*.

The MV of *HexIntegerLiteral* ::: 0X *HexDigit* is the MV of *HexDigit*.

The MV of *HexIntegerLiteral* ::: *HexIntegerLiteral HexDigit* is (the MV of *HexIntegerLiteral* times 16) plus the MV of *HexDigit*.

Once the exact MV for a string numeric literal has been determined, it is then rounded to a value of the Number type. If the MV is 0, then the rounded value is +0 unless the first non white space character in the string numeric literal is '-', in which case the rounded value is -0. Otherwise, the rounded value must be the number value for the MV (in the sense defined in 8.5), unless the literal includes a *StrUnsignedDecimalLiteral* and the literal has more than 20 significant digits, in which case the number value may be either the number value for the MV of a literal produced by replacing each significant digit after the 20th with a 0 digit or the number value for the MV of a literal produced by replacing each significant digit after the 20th with a 0 digit and then incrementing the literal at the 20th digit position. A digit is *significant* if it is not part of an *ExponentPart* and

it is not 0; or

there is a nonzero digit to its left and there is a nonzero digit, not in the *ExponentPart*, to its right.

#### 9.4 ToInteger

The operator ToInteger converts its argument to an integral numeric value. This operator functions as follows:

1. Call ToNumber on the input argument.
2. If Result(1) is NaN, return +0.
3. If Result(1) is +0, -0, +∞, or -∞, return Result(1).
4. Compute sign(Result(1)) \* floor(abs(Result(1))).
5. Return Result(4).

#### 9.5 ToInt32: (Signed 32 Bit Integer)

The operator ToInt32 converts its argument to one of  $2^{32}$  integer values in the range  $-2^{31}$  through  $2^{31}-1$ , inclusive. This operator functions as follows:

1. Call ToNumber on the input argument.
2. If Result(1) is NaN, +0, -0, +∞, or -∞, return +0.
3. Compute sign(Result(1)) \* floor(abs(Result(1))).
4. Compute Result(3) modulo  $2^{32}$ ; that is, a finite integer value  $k$  of Number type with positive sign and less than  $2^{32}$  in magnitude such the mathematical difference of Result(3) and  $k$  is mathematically an integer multiple of  $2^{32}$ .
5. If Result(4) is greater than or equal to  $2^{31}$ , return Result(4) -  $2^{32}$ , otherwise return Result(4).

**NOTE**

Given the above definition of ToInt32:

The ToInt32 operation is idempotent: if applied to a result that it produced, the second application leaves that value unchanged.

ToInt32(ToUint32(x)) is equal to ToInt32(x) for all values of x. (It is to preserve this latter property that +∞ and -∞ are mapped to +0.)

ToInt32 maps -0 to +0.

### 9.6 ToUint32: (Unsigned 32 Bit Integer)

The operator ToUint32 converts its argument to one of  $2^{32}$  integer values in the range 0 through  $2^{32}-1$ , inclusive. This operator functions as follows:

1. Call ToNumber on the input argument.
2. If Result(1) is NaN, +0, -0, +∞, or -∞, return +0.
3. Compute sign(Result(1)) \* floor(abs(Result(1))).
4. Compute Result(3) modulo  $2^{32}$ ; that is, a finite integer value  $k$  of Number type with positive sign and less than  $2^{32}$  in magnitude such the mathematical difference of Result(3) and  $k$  is mathematically an integer multiple of  $2^{32}$ .
5. Return Result(4).

**NOTE**

Given the above definition of ToUint32:

Step 5 is the only difference between ToUint32 and ToInt32.

The ToUint32 operation is idempotent: if applied to a result that it produced, the second application leaves that value unchanged.

ToUint32(ToInt32(x)) is equal to ToUint32(x) for all values of x. (It is to preserve this latter property that +∞ and -∞ are mapped to +0.)

ToUint32 maps -0 to +0.

### 9.7 ToUint16: (Unsigned 16 Bit Integer)

The operator ToUint16 converts its argument to one of  $2^{16}$  integer values in the range 0 through  $2^{16}-1$ , inclusive. This operator functions as follows:

1. Call ToNumber on the input argument.
2. If Result(1) is NaN, +0, -0, +∞, or -∞, return +0.
3. Compute sign(Result(1)) \* floor(abs(Result(1))).
4. Compute Result(3) modulo  $2^{16}$ ; that is, a finite integer value  $k$  of Number type with positive sign and less than  $2^{16}$  in magnitude such the mathematical difference of Result(3) and  $k$  is mathematically an integer multiple of  $2^{16}$ .
5. Return Result(4).

**NOTE**

Given the above definition of ToUint16:

The substitution of  $2^{16}$  for  $2^{32}$  in step 4 is the only difference between ToUint32 and ToUint16.

ToUint16 maps -0 to +0.

## 9.8 ToString

The operator ToString converts its argument to a value of type String according to the following table:

Input Type	Result
Undefined	"undefined"
Null	"null"
Boolean	If the argument is <b>true</b> , then the result is " <b>true</b> ". If the argument is <b>false</b> , then the result is " <b>false</b> ".
Number	See note below.
String	Return the input argument (no conversion)
Object	Apply the following steps: <a href="#">1.</a> Call ToPrimitive(input argument, hint String). <a href="#">2.</a> Call ToString(Result(1)). <a href="#">3.</a> Return Result(2).

### 9.8.1 ToString Applied to the Number Type

The operator ToString converts a number  $m$  to string format as follows:

1. If  $m$  is **NaN**, return the string "**NaN**".
2. If  $m$  is **+0** or **-0**, return the string "**0**".
3. If  $m$  is less than zero, return the string concatenation of the string "-" and ToString( $-m$ ).
4. If  $m$  is infinity, return the string "**Infinity**".
5. Otherwise, let  $n$ ,  $k$ , and  $s$  be integers such that  $k \geq 1$ ,  $10^{k-1} \leq s < 10^k$ , the number value for  $s \times 10^{n-k}$  is  $m$ , and  $k$  is as small as possible. Note that  $k$  is the number of digits in the decimal representation of  $s$ , that  $s$  is not divisible by 10, and that the least significant digit of  $s$  is not necessarily uniquely determined by these criteria.
6. If  $k \leq n \leq 21$ , return the string consisting of the  $k$  digits of the decimal representation of  $s$  (in order, with no leading zeroes), followed by  $n-k$  occurrences of the character '0'.
7. If  $0 < n \leq 21$ , return the string consisting of the most significant  $n$  digits of the decimal representation of  $s$ , followed by a decimal point '.', followed by the remaining  $k-n$  digits of the decimal representation of  $s$ .
8. If  $-6 < n \leq 0$ , return the string consisting of the character '0', followed by a decimal point '.', followed by  $-n$  occurrences of the character '0', followed by the  $k$  digits of the decimal representation of  $s$ .
9. Otherwise, if  $k = 1$ , return the string consisting of the single digit of  $s$ , followed by lowercase character 'e', followed by a plus sign '+' or minus sign '-' according to whether  $n-1$  is positive or negative, followed by the decimal representation of the integer  $\text{abs}(n-1)$  (with no leading zeros).
10. Return the string consisting of the most significant digit of the decimal representation of  $s$ , followed by a decimal point '.', followed by the remaining  $k-1$  digits of the decimal representation of  $s$ , followed by the lowercase character 'e', followed by a plus sign '+' or minus sign '-' according to whether  $n-1$  is positive or negative, followed by the decimal representation of the integer  $\text{abs}(n-1)$  (with no leading zeros).

#### NOTE

The following observations may be useful as guidelines for implementations, but are not part of the normative requirements of this Standard:

If  $x$  is any number value other than **-0**, then  $\text{ToNumber}(\text{ToString}(x))$  is exactly the same number value as  $x$ .

The least significant digit of  $s$  is not always uniquely determined by the requirements listed in step 5.

For implementations that provide more accurate conversions than required by the rules above, it is recommended that the following alternative version of step 5 be used as a guideline:



Otherwise, let  $n$ ,  $k$ , and  $s$  be integers such that  $k \geq 1$ ,  $10^{k-1} \leq s < 10^k$ , the number value for  $s \times 10^{n-k}$  is  $m$ , and  $k$  is as small as possible. If there are multiple possibilities for  $s$ , choose the value of  $s$  for which  $s \times 10^{n-k}$  is closest in value to  $m$ . If there are two such possible values of  $s$ , choose the one that is even. Note that  $k$  is the number of digits in the decimal representation of  $s$  and that  $s$  is not divisible by 10.

Implementors of ECMAScript may find useful the paper and code written by David M. Gay for binary-to-decimal conversion of floating-point numbers:

Gay, David M. *Correctly Rounded Binary-Decimal and Decimal-Binary Conversions*. Numerical Analysis Manuscript 90-10. AT&T Bell Laboratories (Murray Hill, New Jersey). November 30, 1990. Available as <http://cm.bell-labs.com/cm/cs/doc/90/4-10.ps.gz>. Associated code available as <http://cm.bell-labs.com/netlib/fp/dtoa.c.gz> and as [http://cm.bell-labs.com/netlib/fp/g\\_fmt.c.gz](http://cm.bell-labs.com/netlib/fp/g_fmt.c.gz) and may also be found at the various `netlib` mirror sites.

### 9.9 ToObject

The operator ToObject converts its argument to a value of type Object according to the following table:

Input Type	Result
Undefined	Throw a <b>TypeError</b> exception.
Null	Throw a <b>TypeError</b> exception.
Boolean	Create a new Boolean object whose <code>[[PrimitiveValue]]</code> property is set to the value of the boolean. See 15.6 for a description of Boolean objects.
Number	Create a new Number object whose <code>[[PrimitiveValue]]</code> property is set to the value of the number. See 15.7 for a description of Number objects.
String	Create a new String object whose <code>[[PrimitiveValue]]</code> property is set to the value of the string. See 15.5 for a description of String objects.
Object	The result is the input argument (no conversion).

pratapL 6/30/2008 6:59 PM  
 Deleted: value  
 pratapL 6/30/2008 6:59 PM  
 Deleted: value  
 pratapL 6/30/2008 6:59 PM  
 Deleted: value

### 9.10 IsCallable

The operator IsCallable determines if its argument is a callable function Object according to the following table:

Input Type	Result
Undefined	Return <a href="#">false</a> .
Null	Return <a href="#">false</a> .
Boolean	Return <a href="#">false</a> .
Number	Return <a href="#">false</a> .
String	Return <a href="#">false</a> .
Object	If the argument object implements the internal <code>[[Call]]</code> method return <a href="#">true</a> , otherwise return <a href="#">false</a> .

## 10 Execution Contexts

When control is transferred to ECMAScript executable code, control is entering an *execution context*. Active execution contexts logically form a stack. The top execution context on this logical stack is the running execution context.

### 10.1 Definitions

#### 10.1.1 Function Objects

There are two types of Function objects:

Program functions are defined in source text by a *FunctionDeclaration* or created dynamically either by using a *FunctionExpression* or by using the built-in **Function** object as a constructor.

Internal functions are built-in objects of the language, such as `parseInt` and `Math.exp`. An implementation may also provide implementation-dependent internal functions that are not described

in this specification. These functions do not contain executable code defined by the ECMAScript grammar, so they are excluded from this discussion of execution contexts.

### 10.1.2 Types of Executable Code

There are four types of ECMAScript executable code:

*Global code* is source text that is treated as an ECMAScript *Program*. The global code of a particular *Program* does not include any source text that is parsed as part of a *FunctionBody*. The global top-level code of a particular *Program* does not include any source text that is parsed as part of a *Block* or a *FunctionBody*.

*Eval code* is the source text supplied to the built-in `eval` function. More precisely, if the parameter to the built-in `eval` function is a string, it is treated as an ECMAScript *Program*. The eval code for a particular invocation of `eval` is the global code portion of the string parameter. The eval top-level code for a particular invocation of `eval` does not include any source text that is parsed as part of a *Block* or a *FunctionBody*.

*Function code* is source text that is parsed as part of a *FunctionBody*. The *function code* of a particular *FunctionBody* does not include any source text that is parsed as part of a nested *FunctionBody*. The function code of a particular *FunctionBody* does not include any source text that is parsed as part of a *Block* or a *FunctionBody*.

*Function code* also denotes the source text supplied when using the built-in `Function` object as a constructor. More precisely, the last parameter provided to the `Function` constructor is converted to a string and treated as the *FunctionBody*. If more than one parameter is provided to the `Function` constructor, all parameters except the last one are converted to strings and concatenated together, separated by commas. The resulting string is interpreted as the *FormalParameterList* for the *FunctionBody* defined by the last parameter. The function code for a particular instantiation of a `Function` does not include any source text that is parsed as part of a nested *FunctionBody*. The function code for a particular instantiation of a `Function` does not include any source text that is parsed as part of a *Block* or a *FunctionBody*.

Each occurrence of one of these types of code may be restricted to use a defined subset of the complete ECMAScript language.

- Global code is unrestricted unless the *Program* that defines the code includes a `UseSubsetDirective`.
- Eval code inherits the restrictions of the execution context in which the eval operator appears, but its execution context may be further restricted if the *Program* that defines the eval code includes a `UseSubsetDirective`. In that case, the restrictions of the execution context are the union of the restrictions of the inherited execution context and the restrictions specified by the `UseSubsetDirective`. Such a unioning of restrictions is the equivalent of intersecting the specified usage subsets.
- As with Global code, function code supplied as the last argument to the `Function` constructor is unrestricted unless its first statement is an expression statement that conforms to the syntax of a `UseSubsetDirective`.
- Function code made by evaluating a `FunctionDeclaration` or a `FunctionExpression` inherits the restrictions of the execution context in which the evaluation occurs.

### 10.1.3 Variable Instantiation

Every execution context has associated with it a variable object. Variables and functions declared in the source text are added as properties of the variable object. For function code, parameters are added as properties of the variable object.

Which object is used as the variable object and what attributes are used for the properties depends on the type of code, but the remainder of the behaviour is generic. On entering an execution context, the properties are bound to the variable object in the following order:

For function code: for each formal parameter, as defined in the *FormalParameterList*, create a property of the variable object whose name is the *Identifier* and whose attributes are determined by the type of code. The values of the parameters are supplied by the caller as arguments to `[[Call]]`. If the caller

pratapL 5/29/2008 7:57 AM  
Deleted: three

pratapL 5/28/2008 10:42 PM  
Deleted: .

pratapL 7/4/2008 10:07 AM  
Comment [15]: Needs cross-reference.

pratapL 7/4/2008 10:07 AM  
Comment [16]: From AWB: Can we get rid of this case. It complicates a number of things.

supplies fewer parameter values than there are formal parameters, the extra formal parameters have value **undefined**. If two or more formal parameters share the same name, hence the same property, the corresponding property is given the value that was supplied for the last parameter with this name. If the value of this last parameter was not supplied by the caller, the value of the corresponding property is **undefined**.

For each *FunctionDeclaration* in the code, in source text order, create a property of the variable object whose name is the *Identifier* in the *FunctionDeclaration*, whose value is the result returned by creating a Function object as described in 13, and whose attributes are determined by the type of code. If the variable object already has a property with this name, replace its value and attributes. Semantically, this step must follow the creation of *FormalParameterList* properties.

For each *VariableDeclaration* or *VariableDeclarationNoIn* in the code, create a property of the variable object whose name is the *Identifier* in the *VariableDeclaration* or *VariableDeclarationNoIn*, whose value is **undefined** and whose attributes are determined by the type of code. If there is already a property of the variable object with the name of a declared variable, the value of the property and its attributes are not changed. Semantically, this step must follow the creation of the *FormalParameterList* and *FunctionDeclaration* properties. In particular, if a declared variable has the same name as a declared function or formal parameter, the variable declaration does not disturb the existing property.

For each *ConstantDeclaration* in the top-level code create a property of the variable object whose name is the *Identifier* in the *ConstantDeclaration*, whose value is **undefined**, whose `[[Const]]` attribute is the value **Uninitialized**, whose `[[Writable]]` attribute is **false**, and whose other attributes are determined by the type of code. If there is already a property of the variable object with the name of a declared constant, the value of the property and its attributes are not changed. Semantically, this step must follow the creation of the *FormalParameterList*, *FunctionDeclaration*, and *VariableDeclaration* (or *VariableDeclarationNoIn*) properties. In particular, if a declared constant has the same name as a declared function, formal parameter, or variable, the constant declaration does not disturb the existing property.

pratapL 7/4/2008 10:49 AM

**Comment [17]:** From AWB:  
It seems to be that there really should be a cautious subset restriction on this.

#### 10.1.3.1 Usage Subset Restrictions

When defined within an execution context subset restricted to the cautious subset, a function may not have two or more formal parameters that have the same name. An attempt to create a such a function with conflicting parameters names will fail, either statically, if expressed as a *FunctionDeclaration* or *FunctionExpression*, or dynamically by throwing a `SyntaxError` exception, if expressed in a call to the *Function* constructor.

Allen Wirfs-Brock 7/4/2008 10:50 AM

**Comment [18]:** Cautious restriction?

#### 10.1.4 Scope Chain and Identifier Resolution

Every execution context has associated with it a scope chain. A scope chain is a list of objects that are searched when evaluating an *Identifier*. When control enters an execution context, a scope chain is created and populated with an initial set of objects, depending on the type of code. During execution within an execution context, the scope chain of the execution context is affected only by **with** statements (see 12.10) and **catch** clauses (see 12.14).

During execution, the syntactic production *PrimaryExpression* : *Identifier* is evaluated using the following algorithm:

1. Get the next object in the scope chain. If there isn't one, go to step 5.
2. Call the `[[HasProperty]]` method of Result(1), passing the *Identifier* as the property `name`.
3. If Result(2) is **true**, return a value of type Reference whose base object is Result(1) and whose property name is the *Identifier*.
4. Go to step 1.
5. Return a value of type Reference whose base object is **null** and whose property name is the *Identifier*.

The result of evaluating an identifier is always a value of type Reference with its member name component equal to the identifier string.

### 10.1.5 Global Object

There is a unique *global object* (15.1), which is created before control enters any execution context. Initially the global object has the following properties:

Standard built-in objects such as `Math`, `String`, `Date`, `parseInt`, etc. These have attributes `{ [[Enumerable]]: false }`.

Additional host defined properties. This may include a property whose value is the global object itself; for example, in the HTML document object model the `window` property of the global object is the global object itself.

As control enters execution contexts, and as ECMAScript code is executed, additional properties may be added to the global object and the initial properties may be changed.

### 10.1.6 Activation Object

When control enters an execution context for function code, an object called the activation object is created and associated with the execution context. The activation object is initialised with a property with name `arguments` and attributes `{ [[Writable]]: true, [[Enumerable]]: false, [[Flexible]]: false }`. The initial value of this property is the arguments object described below.

The activation object is then used as the variable object for the purposes of variable instantiation.

The activation object is purely a specification mechanism. It is impossible for an ECMAScript program to access the activation object. It can access members of the activation object, but not the activation object itself. When the call operation is applied to a Reference value whose base object is an activation object, `null` is used as the `this` value of the call.

#### 10.1.6.1 Usage Subset cautious Restrictions

For functions defined within an execution subset restricted to the cautious subset, the activation object is only initialized with an "arguments" property if the function mentions "arguments" freely in its body. In which case the "arguments" property is initialized with attributes `{ [[Writable]]: false, [[Enumerable]]: false, [[Flexible]]: false }`.

### 10.1.7 This

There is a `this` value associated with every active execution context. The `this` value depends on the caller and the type of code being executed and is determined when control enters the execution context. The `this` value associated with an execution context is immutable.

### 10.1.8 Arguments Object

When control enters an execution context for function code, an arguments object is created (see above) and initialised as follows:

The value of the internal `[[Prototype]]` property of the arguments object is the original `Array` prototype object, the one that is the initial value of `Array.prototype` (see 15.4.3.1).

A property is created with name `callee` and property attributes `{ [[Writable]]: false, [[Enumerable]]: false, [[Flexible]]: false }`. The initial value of this property is the Function object being executed. This allows anonymous functions to be recursive.

A property is created with name `length` and property attributes `{ [[Enumerable]]: false }`. The initial value of this property is the number of actual parameter values supplied by the caller.

For each non-negative integer, `arg`, less than the value of the `length` property, a property is created with name `ToString(arg)` and property attributes `{ [[Writable]]: true, [[Enumerable]]: false, [[Flexible]]: false }`. The initial value of this property is the value of the corresponding actual parameter supplied by the caller. The first actual parameter value corresponds to `arg = 0`, the second to `arg = 1`, and so on. In the case when `arg` is less than the number of formal parameters for the Function object, this property shares its value with the corresponding property of the activation object. This means that changing this property changes the corresponding property of the activation object and vice versa.

#### 10.1.8.1 Usage Subset cautious Restrictions

For functions defined within an execution subset restricted to the cautious subset, an arguments object is only created if the function mentions "arguments" freely in its body.

pratapL 7/4/2008 10:07 AM

**Comment [19]:** Need a normative list.

pratapL 7/4/2008 10:07 AM

**Comment [20]:** From AWB: It would desirable to also make this `[[Writable]]: false`, and `[[Flexible]]: false` but that may be too incompatible of a change.

pratapL 6/30/2008 7:17 PM

**Deleted:** Built-in

pratapL 5/28/2008 10:47 PM

**Deleted:** DontEnum

pratapL 5/28/2008 10:49 PM

**Deleted:** DontDelete

pratapL 7/4/2008 10:07 AM

**Comment [21]:** From AWB: "mentions freely" needs to be more clearly defined.

pratapL 7/4/2008 10:07 AM

**Comment [22]:** ALP says: Deviations doc §2.4 raises concern over the representation of `arguments.toString()`. ES4 specifies `Object.prototype.toString()` here (see [incompatibilities.pdf §3.4](#)).

pratapL 7/4/2008 10:07 AM

**Comment [23]:** This change is still creating controversy from the ES4 designers.

pratapL 5/28/2008 10:53 PM

**Deleted:** Object

pratapL 5/28/2008 10:53 PM

**Deleted:** Object

pratapL 5/28/2008 10:56 PM

**Deleted:** 2

pratapL 7/4/2008 10:07 AM

**Comment [24]:** From AWB: This appears to be an observable change from ES3. Is that OK?

pratapL 7/4/2008 10:07 AM

**Comment [25]:** From AWB: This appears to be an observable change from ES3. Is that OK?

pratapL 5/28/2008 10:57 PM

**Deleted:** DontEnum

pratapL 7/4/2008 10:07 AM

**Comment [26]:** From AWB: Should other attributes also be specified like for callee?

pratapL 7/3/2008 11:48 AM

**Deleted:** DontEnum

pratapL 7/4/2008 10:07 AM

**Comment [27]:** From AWB: I assume that it must be writable for backwards compatibility.

pratapL 7/4/2008 10:07 AM

**Comment [28]:** From AWB: This is a change ES3. Is it OK?

pratapL 6/16/2008 10:11 AM

**Deleted:** DontEnum

pratapL 7/4/2008 10:07 AM

**Comment [29]:** From AWB: "mentions freely" needs to be more clearly defined.

[If a arguments object is created, a callee property is not created.](#)

[The arguments object does not share properties with the activation object. Changing the value of a arguments object property does not change the value of the corresponding activation object property and vice versa.](#)

## 10.2 Entering An Execution Context

Every function and constructor call enters a new execution context, even if a function is calling itself recursively. Every return exits an execution context. A thrown exception, if not caught, may also exit one or more execution contexts.

When control enters an execution context, the scope chain is created and initialised, variable instantiation is performed, and the **this** value is determined.

The initialisation of the scope chain, variable instantiation, and the determination of the **this** value depend on the type of code being entered.

### 10.2.1 Global Code

The scope chain is created and initialised to contain the global object and no others.

Variable instantiation is performed using the global object as the variable object and using property attributes { [\[\[Writable\]\]: true, \[\[Enumerable\]\]: true, \[\[Flexible\]\]: false](#) }.

The **this** value is the global object.

### 10.2.2 Eval Code

When control enters an execution context for eval code, the previous active execution context, referred to as the *calling context*, is used to determine the scope chain, the variable object, and the **this** value. If there is no calling context, then initialising the scope chain, variable instantiation, and determination of the **this** value are performed just as for global code.

The scope chain is initialised to contain the same objects, in the same order, as the calling context's scope chain. This includes objects added to the calling context's scope chain by **with** statements and **catch** clauses.

Variable instantiation is performed using the calling context's variable object and using [the](#) property attributes { [\[\[Writable\]\]: true, \[\[Enumerable\]\]: true, \[\[Flexible\]\]: true](#) }.

The **this** value is the same as the **this** value of the calling context.

#### 10.2.2.1 Usage Subset *cautious* Restrictions

[If either the execution context for the eval code or the execution context in which the eval operator was executed is subset restricted to the cautious subset, the eval code cannot instantiate variables, functions, or constants in the lexical context of its eval operator.](#)

[Instead, a new variable object is appended to the head of the calling context's scope chain and that variable object is used for variable instantiation with the eval code.](#)

### 10.2.3 Function Code

The scope chain is initialised to contain the activation object followed by the objects in the scope chain stored in the [\[\[Scope\]\]](#) property of the Function object.

Variable instantiation is performed using the activation object as the variable object and using property attributes { [\[\[Writable\]\]: true, \[\[Enumerable\]\]: true, \[\[Flexible\]\]: false](#) }.

The caller provides the **this** value.

pratapL 5/28/2008 11:00 PM  
**Deleted:** DontDelete

pratapL 5/28/2008 11:02 PM  
**Deleted:** empty

pratapL 7/4/2008 10:07 AM  
**Comment [30]:** From AWB:  
This all feels like it needs to be more precisely specified.

pratapL 5/28/2008 11:05 PM  
**Deleted:** DontDelete

pratapL 5/28/2008 11:05 PM  
**Deleted:** If the **this** value provided by the caller is not an object (including the case where it is **null**), then the **this** value is the global object.

## 11 Expressions

### 11.1 Primary Expressions

#### Syntax

*PrimaryExpression* :

- this**
- Identifier*
- Literal*
- ArrayLiteral*
- ObjectLiteral*
- ( *Expression* )

### 11.1.1 The **this** Keyword

The **this** keyword evaluates to the **this** value of the execution context.

#### 11.1.1.1 Usage Subset **cautious Restrictions**

If **this** is evaluated within an execution context that is subset restricted to the **cautious** subset and the **this** value is **null** or **undefined**, then the **this** expression throws a **ReferenceError** exception.

### 11.1.2 Identifier Reference

An *Identifier* is evaluated using the scoping rules stated in 10.1.4. The result of evaluating an *Identifier* is always a value of type Reference.

### 11.1.3 Literal Reference

A *Literal* is evaluated as described in 7.8.

### 11.1.4 Array Initialiser

An array initialiser is an expression describing the initialisation of an Array object, written in a form of a literal. It is a list of zero or more expressions, each of which represents an array element, enclosed in square brackets. The elements need not be literals; they are evaluated each time the array initialiser is evaluated.

Array elements may be elided at the beginning, middle or end of the element list. Whenever a comma in the element list is not preceded by an *AssignmentExpression* (i.e., a comma at the beginning or after another comma), the missing array element contributes to the length of the Array and increases the index of subsequent elements. Elided array elements are not defined. If an element is elided at the end of an array, that element does not contribute to the length of the Array.

## Syntax

*ArrayLiteral* :

- [ *Elision<sub>opt</sub>* ]
- [ *ElementList* ]
- [ *ElementList* , *Elision<sub>opt</sub>* ]

*ElementList* :

- Elision<sub>opt</sub>* *AssignmentExpression*
- ElementList* , *Elision<sub>opt</sub>* *AssignmentExpression*

*Elision* :

- ,
- Elision* ,

## Semantics

The production *ArrayLiteral* : [ *Elision<sub>opt</sub>* ] is evaluated as follows:

1. Create a new object as if by the expression **new Array()** where **Array** is the standard built-in constructor with that name.
2. Evaluate *Elision*; if not present, use the numeric value zero.
3. Call the [[Put]] method of Result(1) with arguments "**length**" and Result(2).
4. Return Result(1).

The production *ArrayLiteral* : [ *ElementList* ] is evaluated as follows:

pratapL 7/4/2008 10:07 AM

**Comment [31]:** From AWB:  
This really should be specified in the grammar if it isn't already.

pratapL 6/30/2008 7:25 PM

**Deleted:** array

1. Evaluate *ElementList*.
2. Return Result(1).

The production *ArrayLiteral* : [ *ElementList* , *Elision<sub>opt</sub>* ] is evaluated as follows:

1. Evaluate *ElementList*.
2. Evaluate *Elision*; if not present, use the numeric value zero.
3. Call the [[Get]] method of Result(1) with argument "length".
4. Call the [[Put]] method of Result(1) with arguments "length" and (Result(2)+Result(3)).
5. Return Result(1).

The production *ElementList* : *Elision<sub>opt</sub>* *AssignmentExpression* is evaluated as follows:

1. Create a new object as if by the expression `new Array ()` where Array is the standard built-in constructor with that name.
2. Evaluate *Elision*; if not present, use the numeric value zero.
3. Evaluate *AssignmentExpression*.
4. Call GetValue(Result(3)).
5. Call the [[Put]] method of Result(1) with arguments Result(2) and Result(4).
6. Return Result(1)

The production *ElementList* : *ElementList* , *Elision<sub>opt</sub>* *AssignmentExpression* is evaluated as follows:

1. Evaluate *ElementList*.
2. Evaluate *Elision*; if not present, use the numeric value zero.
3. Evaluate *AssignmentExpression*.
4. Call GetValue(Result(3)).
5. Call the [[Get]] method of Result(1) with argument "length".
6. Call the [[Put]] method of Result(1) with arguments (Result(2)+Result(5)) and Result(4).
7. Return Result(1)

The production *Elision* : , is evaluated as follows:

1. Return the numeric value 1.

The production *Elision* : *Elision* , is evaluated as follows:

- Evaluate *Elision*.
2. Return (Result(1)+1).

**NOTE:**

The use of [[Put]] rather than [[ThrowablePut]] in this section is intentional as there are no situations where these [[Put]] operations should fail.

**11.1.5 Object Initialiser**

An object initialiser is an expression describing the initialisation of an Object, written in a form resembling a literal. It is a list of zero or more pairs of property names and associated values, enclosed in curly braces. The values need not be literals; they are evaluated each time the object initialiser is evaluated.

**Syntax**

*ObjectLiteral* :

```
{
  }
{ PropertyNameAndValueList }
{ PropertyNameAndValueList , }
```

*PropertyNameAndValueList* :

```
PropertyNameAndValueList
PropertyNameAndValueList , PropertyNameAndValueList
```

pratapL 6/30/2008 7:27 PM  
Deleted: array

pratapL 6/30/2008 11:04 PM  
Deleted: *PropertyName* : *AssignmentExpression*

pratapL 6/30/2008 11:04 PM  
Deleted: *PropertyName* : *AssignmentExpression*

PropertyAssignment :

PropertyName : AssignmentExpression  
get PropertyName ( ) { FunctionBody }  
set PropertyName ( PropertySetParameterList ) { FunctionBody }

PropertyName :

IdentifierName  
StringLiteral  
NumericLiteral

PropertySetParameterList :

Identifier

**Semantics**

The production *ObjectLiteral* : { } is evaluated as follows:

1. Create a new object as if by the expression **new Object()** where Object is the standard built-in constructor with that name.
2. Return Result(1).

The productions *ObjectLiteral* : { *PropertyNameAndValueList* } and { *PropertyNameAndValueList* , } are evaluated as follows:

1. Evaluate *PropertyNameAndValueList*.
2. Return Result(1);

The production

*PropertyNameAndValueList* : PropertyAssignment  
is evaluated as follows:

1. Create a new object as if by the expression **new Object()** where Object is the standard built-in constructor with that name.
2. Evaluate PropertyAssignment.
3. Call the [[DefineOwnProperty]] method of Result(1) with arguments Result(2).name, Result(2).descriptor, false.
4. Return Result(1).

The production

*PropertyNameAndValueList* : *PropertyNameAndValueList* , PropertyAssignment  
is evaluated as follows:

1. Evaluate *PropertyNameAndValueList*.
2. Evaluate PropertyAssignment.
3. Call the [[DefineOwnProperty]] method of Result(1) with arguments (Result(2).name, Result(2).descriptor, false).
4. Return Result(1).

The production *PropertyAssignment* : *PropertyName* : *AssignmentExpression* is evaluated as follows:

1. Evaluate PropertyName.
2. Evaluate AssignmentExpression.
3. Call GetValue(Result(2)).
4. Create Property Descriptor{[[Value]]: Result(2), [[Writable]]: true, [[Enumerable]]: true, [[Flexible]]: true}.
5. Return Property Identifier (Result(1), Result(4)).

The production *PropertyAssignment* : *get PropertyName* ( ) { *FunctionBody* } is evaluated as follows:

1. Evaluate PropertyName.
2. Create a new Function object as specified in 13.2 with an empty parameter list and body specified by FunctionBody. Pass in the scope chain of the running execution context as the Scope.

pratapL 7/2/2008 12:57 PM  
**Deleted:** is

pratapL 6/30/2008 11:10 PM  
**Deleted:** PropertyName : AssignmentExpression

pratapL 6/30/2008 11:11 PM  
**Deleted:** PropertyName

pratapL 6/30/2008 11:14 PM  
**Deleted:** <#>Evaluate AssignmentExpression. -

pratapL 7/4/2008 10:07 AM  
**Comment [32]:** Object literal property definition should never cause [[DefineProperty]] to throw; so, false is fine here.

pratapL 6/30/2008 11:13 PM  
**Deleted:** GetValue(Result(3))

pratapL 6/30/2008 11:13 PM  
**Deleted:** <#>Call the [[Put]] method of Result(1) with arguments Result(2) and Result(4). -

pratapL 6/30/2008 11:14 PM  
**Deleted:** PropertyName : AssignmentExpression

pratapL 6/30/2008 11:14 PM  
**Deleted:** PropertyName

pratapL 6/30/2008 11:14 PM  
**Deleted:** <#>Evaluate AssignmentExpression. -

pratapL 6/30/2008 11:15 PM  
**Deleted:** GetValue(Result(3))

pratapL 6/30/2008 11:15 PM  
**Deleted:** <#>Call the [[Put]] method of Result(1) with arguments Result(2) and Result(4). -



3. Create Property Descriptor{[[Getter]]: Result(2), [[Enumerable]]: true, [[Flexible]]: true}
4. Return Property Identifier (Result(1), Result(4)).

The production *PropertyAssignment* : *set* *PropertyName* ( *PropertySetParameterList* ) { *FunctionBody* } is evaluated as follows:

1. Evaluate *PropertyName*.
2. Create a new Function object as specified in 13.2 with parameters specified by *PropertySetParameterList* and body specified by *FunctionBody*. Pass in the scope chain of the running execution context as the *Scope*.
3. Create Property Descriptor{[[Setter]]: Result(2), [[Enumerable]]: true, [[Flexible]]: true}
4. Return Property Identifier (Result(1), Result(4)).

The production *PropertyName* : *IdentifierName* is evaluated as follows:

1. Form a string literal containing the same sequence of characters as the *IdentifierName*.
2. Return Result(1).

The production *PropertyName* : *StringLiteral* is evaluated as follows:

1. Return the value of the *StringLiteral*.

The production *PropertyName* : *NumericLiteral* is evaluated as follows:

1. Form the value of the *NumericLiteral*.
2. Return ToString(Result(1)).

#### 11.1.6 The Grouping Operator

The production *PrimaryExpression* : ( *Expression* ) is evaluated as follows:

1. Evaluate *Expression*. This may be of type Reference.
2. Return Result(1).

#### NOTE

This algorithm does not apply *GetValue* to Result(1). The principal motivation for this is so that operators such as **delete** and **typeof** may be applied to parenthesised expressions.

### 11.2 Left-Hand-Side Expressions

#### Syntax

*MemberExpression* :

*PrimaryExpression*  
*FunctionExpression*  
*MemberExpression* [ *Expression* ]  
*MemberExpression* . *IdentifierName*  
**new** *MemberExpression* *Arguments*

*NewExpression* :

*MemberExpression*  
**new** *NewExpression*

*CallExpression* :

*MemberExpression* *Arguments*  
*CallExpression* *Arguments*  
*CallExpression* [ *Expression* ]  
*CallExpression* . *IdentifierName*

*Arguments* :

( )  
( *ArgumentList* )

*ArgumentList* :

*AssignmentExpression*  
*ArgumentList* , *AssignmentExpression*

*LeftHandSideExpression* :

*NewExpression*  
*CallExpression*

### 11.2.1 Property Accessors

Properties are accessed by name, using either the dot notation:

*MemberExpression* . *IdentifierName*  
*CallExpression* . *IdentifierName*

or the bracket notation:

*MemberExpression* [ *Expression* ]  
*CallExpression* [ *Expression* ]

The dot notation is explained by the following syntactic conversion:

*MemberExpression* . *IdentifierName*

is identical in its behaviour to

*MemberExpression* [ <*identifier-name-string*> ]

and similarly

*CallExpression* . *IdentifierName*

is identical in its behaviour to

*CallExpression* [ <*identifier-name-string*> ]

where <*identifier-name-string*> is a string literal containing the same sequence of characters as the *IdentifierName*.

The production *MemberExpression* : *MemberExpression* [ *Expression* ] is evaluated as follows:

1. Evaluate *MemberExpression*.
2. Call *GetValue*(Result(1)).
3. Evaluate *Expression*.
4. Call *GetValue*(Result(3)).
5. Call *ToObject*(Result(2)).
6. Call *ToString*(Result(4)).
7. Return a value of type Reference whose base object is Result(5) and whose property name is Result(6).

The production *CallExpression* : *CallExpression* [ *Expression* ] is evaluated in exactly the same manner, except that the contained *CallExpression* is evaluated in step 1.

### 11.2.2 The new Operator

The production *NewExpression* : **new** *NewExpression* is evaluated as follows:

1. Evaluate *NewExpression*.
2. Call *GetValue*(Result(1)).
3. If *Type*(Result(2)) is not Object, throw a **TypeError** exception.
4. If Result(2) does not implement the internal *[[Construct]]* method, throw a **TypeError** exception.
5. Call the *[[Construct]]* method on Result(2), providing no arguments (that is, an empty list of arguments).
6. Return Result(5).

The production *MemberExpression* : **new** *MemberExpression Arguments* is evaluated as follows:

1. Evaluate *MemberExpression*.
2. Call `GetValue(Result(1))`.
3. Evaluate *Arguments*, producing an internal list of argument values (11.2.4).
4. If `Type(Result(2))` is not `Object`, throw a **TypeError** exception.
5. If `Result(2)` does not implement the internal `[[Construct]]` method, throw a **TypeError** exception.
6. Call the `[[Construct]]` method on `Result(2)`, providing the list `Result(3)` as the argument values.
7. Return `Result(6)`.

### 11.2.3 Function Calls

The production *CallExpression* : *MemberExpression Arguments* is evaluated as follows:

1. Evaluate *MemberExpression*.
2. Evaluate *Arguments*, producing an internal list of argument values (see 11.2.4).
3. Call `GetValue(Result(1))`.
4. If `Type(Result(3))` is not `Object`, throw a **TypeError** exception.
5. If `IsCallable(Result(3))` is `false`, throw a **TypeError** exception.
6. If `Type(Result(1))` is `Reference`, `Result(6)` is `GetBase(Result(1))`. Otherwise, `Result(6)` is `null`.
7. If `Result(6)` is an activation object, `Result(7)` is `null`. Otherwise, `Result(7)` is the same as `Result(6)`.
8. Call the `[[Call]]` method on `Result(3)`, providing `Result(7)` as the `this` value and providing the list `Result(2)` as the argument values.
9. Return `Result(8)`.

The production *CallExpression* : *CallExpression Arguments* is evaluated in exactly the same manner, except that the contained *CallExpression* is evaluated in step 1.

#### NOTE

*Result(8)* will never be of type *Reference* if *Result(3)* is a native ECMAScript object. Whether calling a host object can return a value of type *Reference* is implementation-dependent.

### 11.2.4 Argument Lists

The evaluation of an argument list produces an internal list of values (see 8.8).

The production *Arguments* : ( ) is evaluated as follows:

1. Return an empty internal list of values.

The production *Arguments* : ( *ArgumentList* ) is evaluated as follows:

1. Evaluate *ArgumentList*.
2. Return `Result(1)`.

The production *ArgumentList* : *AssignmentExpression* is evaluated as follows:

1. Evaluate *AssignmentExpression*.
2. Call `GetValue(Result(1))`.
3. Return an internal list whose sole item is `Result(2)`.

The production *ArgumentList* : *ArgumentList* , *AssignmentExpression* is evaluated as follows:

1. Evaluate *ArgumentList*.
2. Evaluate *AssignmentExpression*.
3. Call `GetValue(Result(2))`.
4. Return an internal list whose length is one greater than the length of `Result(1)` and whose items are the items of `Result(1)`, in order, followed at the end by `Result(3)`, which is the last item of the new list.

### 11.2.5 Function Expressions

The production *MemberExpression* : *FunctionExpression* is evaluated as follows:

1. Evaluate *FunctionExpression*.
2. Return `Result(1)`.

pratapL 6/30/2008 7:36 PM

**Deleted:** does not implement the internal `[[Call]]` method

pratapL 7/4/2008 10:07 AM

**Comment [33]:** We wanted to remove this possibility but have not done so because this could break bridging to VBScript. Cannot afford to do that as VBScript is still used in the intranet.

### 11.3 Postfix Expressions

#### Syntax

*PostfixExpression* :

*LeftHandSideExpression*

*LeftHandSideExpression* [no *LineTerminator* here] ++

*LeftHandSideExpression* [no *LineTerminator* here] --

#### 11.3.1 Postfix Increment Operator

The production *PostfixExpression* : *LeftHandSideExpression* [no *LineTerminator* here] ++ is evaluated as follows:

1. Evaluate *LeftHandSideExpression*.
2. Call GetValue(Result(1)).
3. Call ToNumber(Result(2)).
4. Add the value 1 to Result(3), using the same rules as for the + operator (see 11.6.3).
5. Call PutValue(Result(1), Result(4), **false**).
6. Return Result(3).

##### 11.3.1.1 Usage Subset *cautious* Restrictions

[When a postfix increment operator occurs within an execution context that is subset restricted to the \*cautious\* subset, its \*LeftHandSide\* must not be a reference to a property with the attribute value `\[\[Writable\]\]: false` nor to a non-existent property of an object whose `\[\[Extensible\]\]` property has the value \*\*false\*\*. In these cases a `TypeError` exception is thrown. This is accomplished by replacing step 5 of the above algorithm with the following:](#)

5. Call PutValue(Result(1), Result(4), **true**).

#### 11.3.2 Postfix Decrement Operator

The production *PostfixExpression* : *LeftHandSideExpression* [no *LineTerminator* here] -- is evaluated as follows:

1. Evaluate *LeftHandSideExpression*.
2. Call GetValue(Result(1)).
3. Call ToNumber(Result(2)).
4. Subtract the value 1 from Result(3), using the same rules as for the - operator (11.6.3).
5. Call PutValue(Result(1), Result(4), **false**).
6. Return Result(3).

##### 11.3.2.1 Usage Subset *cautious* Restrictions

[The same restrictions apply as specified in section 11.3.1.1 for the postfix increment operator.](#)

### 11.4 Unary Operators

#### Syntax

*UnaryExpression* :

*PostfixExpression*

**delete** *UnaryExpression*

**void** *UnaryExpression*

**typeof** *UnaryExpression*

++ *UnaryExpression*

-- *UnaryExpression*

+ *UnaryExpression*

- *UnaryExpression*

~ *UnaryExpression*

! *UnaryExpression*

#### 11.4.1 The **delete** Operator

The production *UnaryExpression* : **delete** *UnaryExpression* is evaluated as follows:

1. Evaluate *UnaryExpression*.
2. If Type(Result(1)) is not Reference, return **true**.
3. Call GetBase(Result(1)).
4. Call GetPropertyName(Result(1)).
5. Call the [[Delete]] method on Result(3), providing (Result(4), **false**) as the arguments.
6. Return Result(5).

pratapL 7/3/2008 1:38 PM  
**Deleted:** as the property name to delete

**11.4.1.1 Usage Subset cautious Restrictions**

When a **delete** operator occurs within an execution context that is subset restricted to the **cautious** subset, its *UnaryExpression* is further limited to being a *MemberExpression*. In addition, if the property to be deleted is has the attribute { [[Flexible]]:false }, a **TypeError** exception is thrown. This is accomplished by replacing step 5 of the above algorithm with the following:

5. Call the [[Delete]] method on Result(3), providing (Result(4), **true**) as the arguments.

**11.4.2 The void Operator**

The production *UnaryExpression* : **void** *UnaryExpression* is evaluated as follows:

1. Evaluate *UnaryExpression*.
2. Call GetValue(Result(1)).
3. Return **undefined**.

**11.4.3 The typeof Operator**

The production *UnaryExpression* : **typeof** *UnaryExpression* is evaluated as follows:

1. Evaluate *UnaryExpression*.
2. If Type(Result(1)) is not Reference, go to step 4.
3. If GetBase(Result(1)) is **null**, return "**undefined**".
4. Call GetValue(Result(1)).
5. Return a string determined by Type(Result(4)) according to the following table:

Type	Result
Undefined	" <b>undefined</b> "
Null	" <b>object</b> "
Boolean	" <b>boolean</b> "
Number	" <b>number</b> "
String	" <b>string</b> "
Object (native and doesn't implement [[Call]])	" <b>object</b> "
Object (native and implements [[Call]])	" <b>function</b> "
Object (host)	Implementation-dependent

**11.4.4 Prefix Increment Operator**

The production *UnaryExpression* : **++** *UnaryExpression* is evaluated as follows:

1. Evaluate *UnaryExpression*.
2. Call GetValue(Result(1)).
3. Call ToNumber(Result(2)).
4. Add the value **1** to Result(3), using the same rules as for the + operator (see 11.6.3).
5. Call PutValue(Result(1), Result(4), **false**).
6. Return Result(4).

**11.4.4.1 Usage Subset cautious Restrictions**

The same restrictions apply as specified in section 11.3.1.1 for the postfix increment operator.

#### 11.4.5 Prefix Decrement Operator

The production *UnaryExpression* : -- *UnaryExpression* is evaluated as follows:

1. Evaluate *UnaryExpression*.
2. Call GetValue(Result(1)).
3. Call ToNumber(Result(2)).
4. Subtract the value 1 from Result(3), using the same rules as for the - operator (see 11.6.3).
5. Call PutValue(Result(1), Result(4), **false**).
6. Return Result(4).

##### 11.4.5.1 Usage Subset cautious Restrictions

[The same restrictions apply as specified in section 11.3.1.1 for the postfix increment operator.](#)

#### 11.4.6 Unary + Operator

The unary + operator converts its operand to Number type.

The production *UnaryExpression* : + *UnaryExpression* is evaluated as follows:

1. Evaluate *UnaryExpression*.
2. Call GetValue(Result(1)).
3. Call ToNumber(Result(2)).
4. Return Result(3).

#### 11.4.7 Unary - Operator

The unary - operator converts its operand to Number type and then negates it. Note that negating +0 produces -0, and negating -0 produces +0.

The production *UnaryExpression* : - *UnaryExpression* is evaluated as follows:

1. Evaluate *UnaryExpression*.
2. Call GetValue(Result(1)).
3. Call ToNumber(Result(2)).
4. If Result(3) is NaN, return NaN.
5. Negate Result(3); that is, compute a number with the same magnitude but opposite sign.
6. Return Result(5).

#### 11.4.8 Bitwise NOT Operator ( ~ )

The production *UnaryExpression* : ~ *UnaryExpression* is evaluated as follows:

1. Evaluate *UnaryExpression*.
2. Call GetValue(Result(1)).
3. Call ToInt32(Result(2)).
4. Apply bitwise complement to Result(3). The result is a signed 32-bit integer.
5. Return Result(4).

#### 11.4.9 Logical NOT Operator ( ! )

The production *UnaryExpression* : ! *UnaryExpression* is evaluated as follows:

1. Evaluate *UnaryExpression*.
2. Call GetValue(Result(1)).
3. Call ToBoolean(Result(2)).
4. If Result(3) is true, return false.
5. Return true.

### 11.5 Multiplicative Operators

#### Syntax

*MultiplicativeExpression* :  
*UnaryExpression*  
*MultiplicativeExpression* \* *UnaryExpression*  
*MultiplicativeExpression* / *UnaryExpression*  
*MultiplicativeExpression* % *UnaryExpression*

#### Semantics

The production *MultiplicativeExpression* : *MultiplicativeExpression* @ *UnaryExpression*, where @ stands for one of the operators in the above definitions, is evaluated as follows:

1. Evaluate *MultiplicativeExpression*.
2. Call GetValue(Result(1)).
3. Evaluate *UnaryExpression*.
4. Call GetValue(Result(3)).
5. Call ToNumber(Result(2)).
6. Call ToNumber(Result(4)).
7. Apply the specified operation (\*, /, or %) to Result(5) and Result(6). See the notes below (11.5.1, 11.5.2, 11.5.3).
8. Return Result(7).

#### 11.5.1 Applying the \* Operator

The \* operator performs multiplication, producing the product of its operands. Multiplication is commutative. Multiplication is not always associative in ECMAScript, because of finite precision.

The result of a floating-point multiplication is governed by the rules of IEEE 754 double-precision arithmetic:

If either operand is NaN, the result is NaN.

The sign of the result is positive if both operands have the same sign, negative if the operands have different signs.

Multiplication of an infinity by a zero results in NaN.

Multiplication of an infinity by an infinity results in an infinity. The sign is determined by the rule already stated above.

Multiplication of an infinity by a finite non-zero value results in a signed infinity. The sign is determined by the rule already stated above.

In the remaining cases, where neither an infinity or NaN is involved, the product is computed and rounded to the nearest representable value using IEEE 754 round-to-nearest mode. If the magnitude is too large to represent, the result is then an infinity of appropriate sign. If the magnitude is too small to represent, the result is then a zero of appropriate sign. The ECMAScript language requires support of gradual underflow as defined by IEEE 754.

#### 11.5.2 Applying the / Operator

The / operator performs division, producing the quotient of its operands. The left operand is the dividend and the right operand is the divisor. ECMAScript does not perform integer division. The operands and result of all division operations are double-precision floating-point numbers. The result of division is determined by the specification of IEEE 754 arithmetic:

If either operand is NaN, the result is NaN.

The sign of the result is positive if both operands have the same sign, negative if the operands have different signs.

Division of an infinity by an infinity results in NaN.

Division of an infinity by a zero results in an infinity. The sign is determined by the rule already stated above.

Division of an infinity by a non-zero finite value results in a signed infinity. The sign is determined by the rule already stated above.

Division of a finite value by an infinity results in zero. The sign is determined by the rule already stated above.

Division of a zero by a zero results in **NaN**; division of zero by any other finite value results in zero, with the sign determined by the rule already stated above.

Division of a non-zero finite value by a zero results in a signed infinity. The sign is determined by the rule already stated above.

In the remaining cases, where neither an infinity, nor a zero, nor **NaN** is involved, the quotient is computed and rounded to the nearest representable value using IEEE 754 round-to-nearest mode. If the magnitude is too large to represent, the operation overflows; the result is then an infinity of appropriate sign. If the magnitude is too small to represent, the operation underflows and the result is a zero of the appropriate sign. The ECMAScript language requires support of gradual underflow as defined by IEEE 754.

### 11.5.3 Applying the % Operator

The % operator yields the remainder from an implied division; the left operand is the dividend and the right operand is the divisor.

#### NOTE

*In C and C++, the remainder operator accepts only integral operands; in ECMAScript, it also accepts floating-point operands.*

The result of a floating-point remainder operation as computed by the % operator is not the same as the “remainder” operation defined by IEEE 754. The IEEE 754 “remainder” operation computes the remainder from a rounding division, not a truncating division, and so its behaviour is not analogous to that of the usual integer remainder operator. Instead the ECMAScript language defines % on floating-point operations to behave in a manner analogous to that of the Java integer remainder operator; this may be compared with the C library function fmod.

The result of a ECMAScript floating-point remainder operation is determined by the rules of IEEE arithmetic:

If either operand is **NaN**, the result is **NaN**.

The sign of the result equals the sign of the dividend.

If the dividend is an infinity, or the divisor is a zero, or both, the result is **NaN**.

If the dividend is finite and the divisor is an infinity, the result equals the dividend.

If the dividend is a zero and the divisor is finite, the result is the same as the dividend.

In the remaining cases, where neither an infinity, nor a zero, nor **NaN** is involved, the floating-point remainder  $r$  from a dividend  $n$  and a divisor  $d$  is defined by the mathematical relation  $r = n - (d * q)$  where  $q$  is an integer that is negative only if  $n/d$  is negative and positive only if  $n/d$  is positive, and whose magnitude is as large as possible without exceeding the magnitude of the true mathematical quotient of  $n$  and  $d$ .

## 11.6 Additive Operators

### Syntax

*AdditiveExpression :*

*MultiplicativeExpression*

*AdditiveExpression + MultiplicativeExpression*

*AdditiveExpression - MultiplicativeExpression*

#### 11.6.1 The Addition operator ( + )

The addition operator either performs string concatenation or numeric addition.

The production *AdditiveExpression : AdditiveExpression + MultiplicativeExpression* is evaluated as follows:

1. Evaluate *AdditiveExpression*.
2. Call `GetValue(Result(1))`.
3. Evaluate *MultiplicativeExpression*.
4. Call `GetValue(Result(3))`.
5. Call `ToPrimitive(Result(2))`.



6. Call ToPrimitive(Result(4)).
7. **If Type(Result(5)) is Decimal or Type(Result(6)) is Decimal, throw a TypeError exception.**
8. If Type(Result(5)) is String or Type(Result(6)) is String, go to step 13. (Note that this step differs from step 3 in the comparison algorithm for the relational operators, by using or instead of and.)
9. Call ToNumber(Result(5)).
10. Call ToNumber(Result(6)).
11. Apply the addition operation to Result(9) and Result(10). See the note below (11.6.3).
12. Return Result(11).
13. Call ToString(Result(5)).
14. Call ToString(Result(6)).
15. Concatenate Result(13) followed by Result(14).
16. Return Result(15).

**NOTE**

No hint is provided in the calls to ToPrimitive in steps 5 and 6. All native ECMAScript objects except Date objects handle the absence of a hint as if the hint Number were given; Date objects handle the absence of a hint as if the hint String were given. Host objects may handle the absence of a hint in some other manner.

**11.6.2 The Subtraction Operator ( - )**

The production *AdditiveExpression* : *AdditiveExpression* - *MultiplicativeExpression* is evaluated as follows:

1. Evaluate *AdditiveExpression*.
2. Call GetValue(Result(1)).
3. Evaluate *MultiplicativeExpression*.
4. Call GetValue(Result(3)).
5. Call ToNumber(Result(2)).
6. Call ToNumber(Result(4)).
7. Apply the subtraction operation to Result(5) and Result(6). See the note below (11.6.3).
8. Return Result(7).

**11.6.3 Applying the Additive Operators ( + , - ) to Numbers**

The + operator performs addition when applied to two operands of numeric type, producing the sum of the operands. The - operator performs subtraction, producing the difference of two numeric operands.

Addition is a commutative operation, but not always associative.

The result of an addition is determined using the rules of IEEE 754 double-precision arithmetic:

If either operand is NaN, the result is NaN.

The sum of two infinities of opposite sign is NaN.

The sum of two infinities of the same sign is the infinity of that sign.

The sum of an infinity and a finite value is equal to the infinite operand.

The sum of two negative zeros is -0. The sum of two positive zeros, or of two zeros of opposite sign, is +0.

The sum of a zero and a nonzero finite value is equal to the nonzero operand.

The sum of two nonzero finite values of the same magnitude and opposite sign is +0.

In the remaining cases, where neither an infinity, nor a zero, nor NaN is involved, and the operands have the same sign or have different magnitudes, the sum is computed and rounded to the nearest representable value using IEEE 754 round-to-nearest mode. If the magnitude is too large to represent, the operation overflows and the result is then an infinity of appropriate sign. The ECMAScript language requires support of gradual underflow as defined by IEEE 754.

The - operator performs subtraction when applied to two operands of numeric type, producing the difference of its operands; the left operand is the minuend and the right operand is the subtrahend. Given numeric operands a and b, it is always the case that a-b produces the same result as a+(-b).

- pratapL 7/4/2008 10:07 AM  
**Comment [34]:** Needs to be specified more precisely.
- pratapL 7/3/2008 1:31 AM  
**Deleted:** 12
- pratapL 7/3/2008 1:31 AM  
**Deleted:** 8
- pratapL 7/3/2008 1:31 AM  
**Deleted:** 9
- pratapL 7/3/2008 1:31 AM  
**Deleted:** 10
- pratapL 7/3/2008 1:32 AM  
**Deleted:** 12
- pratapL 7/3/2008 1:32 AM  
**Deleted:** 13
- pratapL 7/3/2008 1:32 AM  
**Deleted:** 14

## 11.7 Bitwise Shift Operators

### Syntax

*ShiftExpression* :

*AdditiveExpression*

*ShiftExpression* << *AdditiveExpression*

*ShiftExpression* >> *AdditiveExpression*

*ShiftExpression* >>> *AdditiveExpression*

### 11.7.1 The Left Shift Operator ( << )

Performs a bitwise left shift operation on the left operand by the amount specified by the right operand.

The production *ShiftExpression* : *ShiftExpression* << *AdditiveExpression* is evaluated as follows:

1. Evaluate *ShiftExpression*.
2. Call GetValue(Result(1)).
3. Evaluate *AdditiveExpression*.
4. Call GetValue(Result(3)).
5. Call ToInt32(Result(2)).
6. Call ToUInt32(Result(4)).
7. Mask out all but the least significant 5 bits of Result(6), that is, compute Result(6) & 0x1F.
8. Left shift Result(5) by Result(7) bits. The result is a signed 32 bit integer.
9. Return Result(8).

### 11.7.2 The Signed Right Shift Operator ( >> )

Performs a sign-filling bitwise right shift operation on the left operand by the amount specified by the right operand.

The production *ShiftExpression* : *ShiftExpression* >> *AdditiveExpression* is evaluated as follows:

1. Evaluate *ShiftExpression*.
2. Call GetValue(Result(1)).
3. Evaluate *AdditiveExpression*.
4. Call GetValue(Result(3)).
5. Call ToInt32(Result(2)).
6. Call ToUInt32(Result(4)).
7. Mask out all but the least significant 5 bits of Result(6), that is, compute Result(6) & 0x1F.
8. Perform sign-extending right shift of Result(5) by Result(7) bits. The most significant bit is propagated. The result is a signed 32 bit integer.
9. Return Result(8).

### 11.7.3 The Unsigned Right Shift Operator ( >>> )

Performs a zero-filling bitwise right shift operation on the left operand by the amount specified by the right operand.

The production *ShiftExpression* : *ShiftExpression* >>> *AdditiveExpression* is evaluated as follows:

1. Evaluate *ShiftExpression*.
2. Call GetValue(Result(1)).
3. Evaluate *AdditiveExpression*.
4. Call GetValue(Result(3)).
5. Call ToInt32(Result(2)).
6. Call ToUInt32(Result(4)).
7. Mask out all but the least significant 5 bits of Result(6), that is, compute Result(6) & 0x1F.
8. Perform zero-filling right shift of Result(5) by Result(7) bits. Vacated bits are filled with zero. The result is an unsigned 32 bit integer.
9. Return Result(8).

## 11.8 Relational Operators

### Syntax

*RelationalExpression* :

*ShiftExpression*

*RelationalExpression* < *ShiftExpression*

*RelationalExpression* > *ShiftExpression*

*RelationalExpression* <= *ShiftExpression*

*RelationalExpression* >= *ShiftExpression*

*RelationalExpression* **instanceof** *ShiftExpression*

*RelationalExpression* **in** *ShiftExpression*

*RelationalExpressionNoIn* :

*ShiftExpression*

*RelationalExpressionNoIn* < *ShiftExpression*

*RelationalExpressionNoIn* > *ShiftExpression*

*RelationalExpressionNoIn* <= *ShiftExpression*

*RelationalExpressionNoIn* >= *ShiftExpression*

*RelationalExpressionNoIn* **instanceof** *ShiftExpression*

NOTE

The 'NoIn' variants are needed to avoid confusing the *in* operator in a relational expression with the *in* operator in a *for* statement.

**Semantics**

The result of evaluating a relational operator is always of type Boolean, reflecting whether the relationship named by the operator holds between its two operands.

The *RelationalExpressionNoIn* productions are evaluated in the same manner as the *RelationalExpression* productions except that the contained *RelationalExpressionNoIn* is evaluated instead of the contained *RelationalExpression*.

#### 11.8.1 The Less-than Operator ( < )

The production *RelationalExpression* : *RelationalExpression* < *ShiftExpression* is evaluated as follows:

1. Evaluate *RelationalExpression*.
2. Call GetValue(Result(1)).
3. Evaluate *ShiftExpression*.
4. Call GetValue(Result(3)).
5. Perform the comparison Result(2) < Result(4). (see 11.8.5)
6. If Result(5) is **undefined**, return **false**. Otherwise, return Result(5).

#### 11.8.2 The Greater-than Operator ( > )

The production *RelationalExpression* : *RelationalExpression* > *ShiftExpression* is evaluated as follows:

1. Evaluate *RelationalExpression*.
2. Call GetValue(Result(1)).
3. Evaluate *ShiftExpression*.
4. Call GetValue(Result(3)).
5. Perform the comparison Result(4) < Result(2) [with LeftFirst equal to false](#). (see 11.8.5).
6. If Result(5) is **undefined**, return **false**. Otherwise, return Result(5).

#### 11.8.3 The Less-than-or-equal Operator ( <= )

The production *RelationalExpression* : *RelationalExpression* <= *ShiftExpression* is evaluated as follows:

1. Evaluate *RelationalExpression*.
2. Call GetValue(Result(1)).
3. Evaluate *ShiftExpression*.
4. Call GetValue(Result(3)).
5. Perform the comparison Result(4) < Result(2) [with LeftFirst equal to false](#). (see 11.8.5).
6. If Result(5) is **true** or **undefined**, return **false**. Otherwise, return **true**.

### 11.8.4 The Greater-than-or-equal Operator (>=)

The production *RelationalExpression* : *RelationalExpression* >= *ShiftExpression* is evaluated as follows:

1. Evaluate *RelationalExpression*.
2. Call GetValue(Result(1)).
3. Evaluate *ShiftExpression*.
4. Call GetValue(Result(3)).
5. Perform the comparison Result(2) < Result(4). (see 11.8.5).
6. If Result(5) is **true** or **undefined**, return **false**. Otherwise, return **true**.

### 11.8.5 The Abstract Relational Comparison Algorithm

The comparison  $x < y$ , where  $x$  and  $y$  are values, produces **true**, **false**, or **undefined** (which indicates that at least one operand is NaN). In addition to  $x$  and  $y$  the algorithm takes a boolean flag named *LeftFirst* as a parameter. The flag is used to control the order in which operations with potentially visible side-effects are performed upon  $x$  and  $y$ . It is necessary because ECMAScript specifies left to right evaluation of expressions. The default value of *LeftFirst* is **true** and indicates that the  $x$  parameter corresponds to an expression that occurs to the left of the  $y$  parameters corresponding expression. If *LeftFirst* is **false**, the reverse is the case and operations must be performed upon  $y$  before  $x$ . Such a comparison is performed as follows:

1. If the *LeftFirst* flag is true, then
  - a. Let  $px$  be the result of calling ToPrimitive( $x$ , hint Number).
  - b. Let  $py$  be the result of calling ToPrimitive( $y$ , hint Number).
2. Else the order of evaluation needs to be reversed to preserve left to right evaluation
  - a. Let  $py$  be the result of calling ToPrimitive( $y$ , hint Number).
  - b. Let  $px$  be the result of calling ToPrimitive( $x$ , hint Number).
3. If Type( $px$ ) is String or Type( $py$ ) is String, go to step 16. (Note that this step differs from step 7 in the algorithm for the addition operator + in using *and* instead of *or*.)
4. Let  $nx$  be the result of calling ToNumber( $px$ ). Because of  $px$  and  $py$  are primitive values evaluation order is not important.
5. Let  $ny$  be the result of calling ToNumber( $py$ ).
6. If  $nx$  is NaN, return **undefined**.
7. If  $ny$  is NaN, return **undefined**.
8. If  $nx$  and  $ny$  are the same number value, return **false**.
9. If  $nx$  is +0 and  $ny$  is -0, return **false**.
10. If  $nx$  is -0 and  $ny$  is +0, return **false**.
11. If  $nx$  is +∞, return **false**.
12. If  $ny$  is +∞, return **true**.
13. If  $ny$  is -∞, return **false**.
14. If  $nx$  is -∞, return **true**.
15. If the mathematical value of  $nx$  is less than the mathematical value of  $ny$ ,—note that these mathematical values are both finite and not both zero—return **true**. Otherwise, return **false**.
16. If  $py$  is a prefix of  $px$ , return **false**. (A string value  $p$  is a prefix of string value  $q$  if  $q$  can be the result of concatenating  $p$  and some other string  $r$ . Note that any string is a prefix of itself, because  $r$  may be the empty string.)
17. If  $px$  is a prefix of  $py$ , return **true**.
18. Let  $k$  be the smallest nonnegative integer such that the character at position  $k$  within  $px$  is different from the character at position  $k$  within  $py$ . (There must be such a  $k$ , for neither string is a prefix of the other.)
19. Let  $m$  be the integer that is the code point value for the character at position  $k$  within  $px$ .
20. Let  $n$  be the integer that is the code point value for the character at position  $k$  within  $py$ .
21. If  $m < n$ , return **true**. Otherwise, return **false**.

**NOTE**

The comparison of strings uses a simple lexicographic ordering on sequences of code point value values. There is no attempt to use the more complex, semantically oriented definitions of character or string equality and collating order defined in the Unicode specification. Therefore strings that are canonically equal according to the Unicode standard could test as unequal. In effect this algorithm assumes that both strings are already in normalised form.

pratapL 7/2/2008 1:13 PM  
Deleted: Call

pratapL 7/2/2008 1:14 PM  
Deleted: Call

pratapL 7/4/2008 10:07 AM  
Comment [35]: See Deviations doc item 2.8

pratapL 7/2/2008 1:16 PM  
Deleted: Result(1)...x is String and ... [19]

pratapL 7/2/2008 1:16 PM  
Deleted: Result(2)

pratapL 7/2/2008 1:17 PM  
Deleted: Call ...et nx be the result of calling ... [10]

pratapL 7/2/2008 1:18 PM  
Deleted: Call ...oNumber(Result(2)) ... [11]

pratapL 7/2/2008 1:19 PM  
Deleted: Result(4)

pratapL 7/2/2008 1:19 PM  
Deleted: Result(5)

pratapL 7/2/2008 1:19 PM  
Deleted: Result(4)...x is +0 and Result(5) ... [12]

pratapL 7/2/2008 1:19 PM  
Deleted: Result(4)...x is -0 and nyResult(5) ... [13]

pratapL 7/2/2008 1:20 PM  
Deleted: Result(4)...x is -0 and nyResult(5) ... [14]

pratapL 7/2/2008 1:20 PM  
Deleted: Result(4)

pratapL 7/2/2008 1:20 PM  
Deleted: Result(5)

pratapL 7/2/2008 1:20 PM  
Deleted: Result(5)

pratapL 7/2/2008 1:20 PM  
Deleted: Result(4)

pratapL 7/2/2008 1:20 PM  
Deleted: Result(5)

pratapL 7/2/2008 1:20 PM  
Deleted: Result(4)

pratapL 7/2/2008 1:21 PM  
Deleted: Result(4)...x is less than the mathematic... [15]

pratapL 7/2/2008 1:21 PM  
Deleted: Result(2)...y is a prefix of Result(1) ... [16]

pratapL 7/2/2008 1:22 PM  
Deleted: Result(1)...x is a prefix of Result(2) ... [17]

pratapL 7/2/2008 1:22 PM  
Deleted: Result(1)...x is different from the charac... [18]

pratapL 7/2/2008 1:22 PM  
Deleted: Result(1)

pratapL 7/2/2008 1:22 PM  
Deleted: Result(2)

### 11.8.6 The instanceof operator

The production *RelationalExpression* : *RelationalExpression instanceof ShiftExpression* is evaluated as follows:

1. Evaluate *RelationalExpression*.
2. Call GetValue(Result(1)).
3. Evaluate *ShiftExpression*.
4. Call GetValue(Result(3)).
5. If Result(4) is not an object, throw a **TypeError** exception.
6. If Result(4) does not have a `[[HasInstance]]` method, throw a **TypeError** exception.
7. Call the `[[HasInstance]]` method of Result(4) with parameter Result(2).
8. Return Result(7).

### 11.8.7 The in operator

The production *RelationalExpression* : *RelationalExpression in ShiftExpression* is evaluated as follows:

1. Evaluate *RelationalExpression*.
2. Call GetValue(Result(1)).
3. Evaluate *ShiftExpression*.
4. Call GetValue(Result(3)).
5. If Result(4) is not an object, throw a **TypeError** exception.
6. Call ToString(Result(2)).
7. Call the `[[HasProperty]]` method of Result(4) with parameter Result(6).
8. Return Result(7).

## 11.9 Equality Operators

### Syntax

*EqualityExpression* :

*RelationalExpression*  
*EqualityExpression* == *RelationalExpression*  
*EqualityExpression* != *RelationalExpression*  
*EqualityExpression* === *RelationalExpression*  
*EqualityExpression* !== *RelationalExpression*

*EqualityExpressionNoIn* :

*RelationalExpressionNoIn*  
*EqualityExpressionNoIn* == *RelationalExpressionNoIn*  
*EqualityExpressionNoIn* != *RelationalExpressionNoIn*  
*EqualityExpressionNoIn* === *RelationalExpressionNoIn*  
*EqualityExpressionNoIn* !== *RelationalExpressionNoIn*

### Semantics

The result of evaluating an equality operator is always of type Boolean, reflecting whether the relationship named by the operator holds between its two operands.

The *EqualityExpressionNoIn* productions are evaluated in the same manner as the *EqualityExpression* productions except that the contained *EqualityExpressionNoIn* and *RelationalExpressionNoIn* are evaluated instead of the contained *EqualityExpression* and *RelationalExpression*, respectively.

### 11.9.1 The Equals Operator ( == )

The production *EqualityExpression* : *EqualityExpression == RelationalExpression* is evaluated as follows:

1. Evaluate *EqualityExpression*.
2. Call GetValue(Result(1)).
3. Evaluate *RelationalExpression*.
4. Call GetValue(Result(3)).
5. Perform the comparison Result(4) == Result(2). (see 11.9.3).

6. Return Result(5).

### 11.9.2 The Does-not-equals Operator ( != )

The production *EqualityExpression* : *EqualityExpression* != *RelationalExpression* is evaluated as follows:

1. Evaluate *EqualityExpression*.
2. Call GetValue(Result(1)).
3. Evaluate *RelationalExpression*.
4. Call GetValue(Result(3)).
5. Perform the comparison Result(4) == Result(2). (see 11.9.3).
6. If Result(5) is **true**, return **false**. Otherwise, return **true**.

### 11.9.3 The Abstract Equality Comparison Algorithm

The comparison *x* == *y*, where *x* and *y* are values, produces **true** or **false**. Such a comparison is performed as follows:

1. If Type(*x*) is different from Type(*y*), go to step 14.
2. If Type(*x*) is Undefined, return **true**.
3. If Type(*x*) is Null, return **true**.
4. [If Type\(\*x\*\) is Decimal, return the result of \*x\*.compareTo\(\*y\*\) == 0](#)
5. If Type(*x*) is not Number, go to step [12](#).
6. If *x* is NaN, return **false**.
7. If *y* is NaN, return **false**.
8. If *x* is the same number value as *y*, return **true**.
9. If *x* is +0 and *y* is -0, return **true**.
10. If *x* is -0 and *y* is +0, return **true**.
11. Return **false**.
12. If Type(*x*) is String, then return **true** if *x* and *y* are exactly the same sequence of characters (same length and same characters in corresponding positions). Otherwise, return **false**.
13. If Type(*x*) is Boolean, return **true** if *x* and *y* are both **true** or both **false**. Otherwise, return **false**.
14. Return **true** if *x* and *y* refer to the same object. Otherwise, return **false**.
15. If *x* is null and *y* is undefined, return **true**.
16. If *x* is undefined and *y* is null, return **true**.
17. If Type(*x*) is Number and Type(*y*) is String, return the result of the comparison *x* == ToNumber(*y*).
18. If Type(*x*) is String and Type(*y*) is Number, return the result of the comparison ToNumber(*x*) == *y*.
19. If Type(*x*) is Boolean, return the result of the comparison ToNumber(*x*) == *y*.
20. If Type(*y*) is Boolean, return the result of the comparison *x* == ToNumber(*y*).
21. If Type(*x*) is either String or Number and Type(*y*) is Object, return the result of the comparison *x* == ToPrimitive(*y*).
22. If Type(*x*) is Object and Type(*y*) is either String or Number, return the result of the comparison ToPrimitive(*x*) == *y*.
23. Return **false**.

#### NOTE

Given the above definition of equality:

String comparison can be forced by: `" " + a == " " + b`.

Numeric comparison can be forced by: `a - 0 == b - 0`.

Boolean comparison can be forced by: `!a == !b`.

The equality operators maintain the following invariants:

**A != B** is equivalent to **!(A == B)**.

**A == B** is equivalent to **B == A**, except in the order of evaluation of **A** and **B**.

pratapL 7/4/2008 10:07 AM

**Comment [36]:** Needs to be specified more precisely.

pratapL 7/3/2008 1:37 AM

**Deleted:** 11

pratapL 5/28/2008 11:20 PM

**Deleted:** or if they refer to objects joined to each other (see 13.1.2)

The equality operator is not always transitive. For example, there might be two distinct *String* objects, each representing the same string value; each *String* object would be considered equal to the string value by the `==` operator, but the two *String* objects would not be equal to each other.

Comparison of strings uses a simple equality test on sequences of code point value values. There is no attempt to use the more complex, semantically oriented definitions of character or string equality and collating order defined in the Unicode 2.0 specification. Therefore strings that are canonically equal according to the Unicode standard could test as unequal. In effect this algorithm assumes that both strings are already in normalised form.

#### 11.9.4 The Strict Equals Operator ( `===` )

The production *EqualityExpression* : *EqualityExpression* `===` *RelationalExpression* is evaluated as follows:

1. Evaluate *EqualityExpression*.
2. Call `GetValue(Result(1))`.
3. Evaluate *RelationalExpression*.
4. Call `GetValue(Result(3))`.
5. Perform the comparison `Result(4) === Result(2)`. (See below.)
6. Return `Result(5)`.

#### 11.9.5 The Strict Does-not-equal Operator ( `!==` )

The production *EqualityExpression* : *EqualityExpression* `!==` *RelationalExpression* is evaluated as follows:

1. Evaluate *EqualityExpression*.
2. Call `GetValue(Result(1))`.
3. Evaluate *RelationalExpression*.
4. Call `GetValue(Result(3))`.
5. Perform the comparison `Result(4) === Result(2)`. (See below.)
6. If `Result(5)` is **true**, return **false**. Otherwise, return **true**.

#### 11.9.6 The Strict Equality Comparison Algorithm

The comparison `x === y`, where `x` and `y` are values, produces **true** or **false**. Such a comparison is performed as follows:

1. If `Type(x)` is different from `Type(y)`, return **false**.
2. If `Type(x)` is **Undefined**, return **true**.
3. If `Type(x)` is **Null**, return **true**.
4. If `Type(x)` is not **Number**, go to step 11.
5. If `x` is **NaN**, return **false**.
6. If `y` is **NaN**, return **false**.
7. If `x` is the same number value as `y`, return **true**.
8. If `x` is `+0` and `y` is `-0`, return **true**.
9. If `x` is `-0` and `y` is `+0`, return **true**.
10. Return **false**.
11. If `Type(x)` is **String**, then return **true** if `x` and `y` are exactly the same sequence of characters (same length and same characters in corresponding positions); otherwise, return **false**.
12. If `Type(x)` is **Boolean**, return **true** if `x` and `y` are both **true** or both **false**; otherwise, return **false**.
13. Return **true** if `x` and `y` refer to the same object. Otherwise, return **false**.

### 11.10 Binary Bitwise Operators

#### Syntax

*BitwiseANDExpression* :  
*EqualityExpression*  
*BitwiseANDExpression* & *EqualityExpression*

*BitwiseANDExpressionNoIn* :  
*EqualityExpressionNoIn*  
*BitwiseANDExpressionNoIn* & *EqualityExpressionNoIn*

*BitwiseXORExpression* :  
*BitwiseANDExpression*  
*BitwiseXORExpression* ^ *BitwiseANDExpression*

*BitwiseXORExpressionNoIn* :  
*BitwiseANDExpressionNoIn*  
*BitwiseXORExpressionNoIn* ^ *BitwiseANDExpressionNoIn*

*BitwiseORExpression* :  
*BitwiseXORExpression*  
*BitwiseORExpression* | *BitwiseXORExpression*

*BitwiseORExpressionNoIn* :  
*BitwiseXORExpressionNoIn*  
*BitwiseORExpressionNoIn* | *BitwiseXORExpressionNoIn*

#### Semantics

The production  $A : A @ B$ , where @ is one of the bitwise operators in the productions above, is evaluated as follows:

1. Evaluate  $A$ .
2. Call GetValue(Result(1)).
3. Evaluate  $B$ .
4. Call GetValue(Result(3)).
5. Call ToInt32(Result(2)).
6. Call ToInt32(Result(4)).
7. Apply the bitwise operator @ to Result(5) and Result(6). The result is a signed 32 bit integer.
8. Return Result(7).

### 11.11 Binary Logical Operators

#### Syntax

*LogicalANDExpression* :  
*BitwiseORExpression*  
*LogicalANDExpression* && *BitwiseORExpression*

*LogicalANDExpressionNoIn* :  
*BitwiseORExpressionNoIn*  
*LogicalANDExpressionNoIn* && *BitwiseORExpressionNoIn*

*LogicalORExpression* :  
*LogicalANDExpression*  
*LogicalORExpression* || *LogicalANDExpression*

*LogicalORExpressionNoIn* :  
*LogicalANDExpressionNoIn*  
*LogicalORExpressionNoIn* || *LogicalANDExpressionNoIn*

#### Semantics

The production *LogicalANDExpression* : *LogicalANDExpression* && *BitwiseORExpression* is evaluated as follows:

1. Evaluate *LogicalANDExpression*.
2. Call GetValue(Result(1)).



3. Call `ToBoolean(Result(2))`.
4. If `Result(3)` is **false**, return `Result(2)`.
5. Evaluate *BitwiseORExpression*.
6. Call `GetValue(Result(5))`.
7. Return `Result(6)`.

The production *LogicalORExpression : LogicalORExpression || LogicalANDExpression* is evaluated as follows:

1. Evaluate *LogicalORExpression*.
2. Call `GetValue(Result(1))`.
3. Call `ToBoolean(Result(2))`.
4. If `Result(3)` is **true**, return `Result(2)`.
5. Evaluate *LogicalANDExpression*.
6. Call `GetValue(Result(5))`.
7. Return `Result(6)`.

The *LogicalANDExpressionNoIn* and *LogicalORExpressionNoIn* productions are evaluated in the same manner as the *LogicalANDExpression* and *LogicalORExpression* productions except that the contained *LogicalANDExpressionNoIn*, *BitwiseORExpressionNoIn* and *LogicalORExpressionNoIn* are evaluated instead of the contained *LogicalANDExpression*, *BitwiseORExpression* and *LogicalORExpression*, respectively.

**NOTE**

The value produced by a **&&** or **||** operator is not necessarily of type *Boolean*. The value produced will always be the value of one of the two operand expressions.

### 11.12 Conditional Operator ( **?:** )

**Syntax**

*ConditionalExpression* :

*LogicalORExpression*

*LogicalORExpression* ? *AssignmentExpression* : *AssignmentExpression*

*ConditionalExpressionNoIn* :

*LogicalORExpressionNoIn*

*LogicalORExpressionNoIn* ? *AssignmentExpression* : *AssignmentExpressionNoIn*

**Semantics**

The production *ConditionalExpression : LogicalORExpression ? AssignmentExpression : AssignmentExpression* is evaluated as follows:

1. Evaluate *LogicalORExpression*.
2. Call `GetValue(Result(1))`.
3. Call `ToBoolean(Result(2))`.
4. If `Result(3)` is **false**, go to step 8.
5. Evaluate the first *AssignmentExpression*.
6. Call `GetValue(Result(5))`.
7. Return `Result(6)`.
8. Evaluate the second *AssignmentExpression*.
9. Call `GetValue(Result(8))`.
10. Return `Result(9)`.

The *ConditionalExpressionNoIn* production is evaluated in the same manner as the *ConditionalExpression* production except that the contained *LogicalORExpressionNoIn*, *AssignmentExpression* and *AssignmentExpressionNoIn* are evaluated instead of the contained *LogicalORExpression*, first *AssignmentExpression* and second *AssignmentExpression*, respectively.

**NOTE**

The grammar for a *ConditionalExpression* in ECMAScript is a little bit different from that in C and Java, which each allow the second subexpression to be an *Expression* but restrict the third expression to be a *ConditionalExpression*. The motivation for this difference in ECMAScript is to allow an assignment expression to be governed by either arm of a conditional and to eliminate the confusing and fairly useless case of a comma expression as the centre expression.

### 11.13 Assignment Operators

#### Syntax

*AssignmentExpression* :  
    *ConditionalExpression*  
    *LeftHandSideExpression* *AssignmentOperator* *AssignmentExpression*

*AssignmentExpressionNoIn* :  
    *ConditionalExpressionNoIn*  
    *LeftHandSideExpression* *AssignmentOperator* *AssignmentExpressionNoIn*

*AssignmentOperator* : one of  
=    \*=    /=    %=    +=    -=    <<=    >>=    >>>=    &=    ^=    |=

#### Semantics

The *AssignmentExpressionNoIn* productions are evaluated in the same manner as the *AssignmentExpression* productions except that the contained *ConditionalExpressionNoIn* and *AssignmentExpressionNoIn* are evaluated instead of the contained *ConditionalExpression* and *AssignmentExpression*, respectively.

#### 11.13.1 Simple Assignment ( = )

The production *AssignmentExpression* : *LeftHandSideExpression* = *AssignmentExpression* is evaluated as follows:

1. Evaluate *LeftHandSideExpression*.
2. Evaluate *AssignmentExpression*.
3. Call `GetValue(Result(2))`.
4. Call `PutValue(Result(1), Result(3), false)`.
5. Return `Result(3)`.

##### 11.13.1.1 Usage Subset cautious Restrictions

[When a simple assignment occurs within an execution context that is subset restricted to the cautious subset, its \*LeftHandSide\* must not evaluate to a Reference to a property of the Global Object. If it does a \*\*ReferenceError\*\* exception is thrown. The \*LeftHandSide\* also may not be a reference to a property with the attribute value `{\[\[Writable\]\]:false}` nor to a non-existent property of an object whose `\[\[Extensible\]\]` property has the value `false`. In these cases a \*\*TypeError\*\* exception is thrown. This is accomplished by replacing step 5 of the above algorithm with the following:](#)

5. Call `PutValue(Result(1), Result(3), true)`.

#### 11.13.2 Compound Assignment ( op= )

The production *AssignmentExpression* : *LeftHandSideExpression* @ = *AssignmentExpression*, where @ represents one of the operators indicated above, is evaluated as follows:

1. Evaluate *LeftHandSideExpression*.
2. Call `GetValue(Result(1))`.
3. Evaluate *AssignmentExpression*.
4. Call `GetValue(Result(3))`.
5. Apply operator @ to `Result(2)` and `Result(4)`.
6. Call `PutValue(Result(1), Result(5), false)`.
7. Return `Result(5)`.

##### 11.13.2.1 Usage Subset cautious Restrictions

[The same restrictions apply as specified in 11.13.1.1 except that the algorithm change is:](#)

[6. Call PutValue\(Result\(1\), Result\(5\), true\).](#)

#### 11.14 Comma Operator ( , )

##### Syntax

*Expression* :

*AssignmentExpression*  
*Expression* , *AssignmentExpression*

*ExpressionNoIn* :

*AssignmentExpressionNoIn*  
*ExpressionNoIn* , *AssignmentExpressionNoIn*

##### Semantics

The production *Expression* : *Expression* , *AssignmentExpression* is evaluated as follows:

1. Evaluate *Expression*.
2. Call GetValue(Result(1)).
3. Evaluate *AssignmentExpression*.
4. Call GetValue(Result(3)).
5. Return Result(4).

The *ExpressionNoIn* production is evaluated in the same manner as the *Expression* production except that the contained *ExpressionNoIn* and *AssignmentExpressionNoIn* are evaluated instead of the contained *Expression* and *AssignmentExpression*, respectively.

DRAFT

## 12 Statements

### Syntax

Statement :

- [SubStatement](#)
- [ConstantStatement](#)
- [VariableStatement](#)
- [FunctionDeclaration](#)

SubStatement :

- [Block](#)
- [EmptyStatement](#)
- [ExpressionStatement](#)
- [IfStatement](#)
- [IterationStatement](#)
- [ContinueStatement](#)
- [BreakStatement](#)
- [ReturnStatement](#)
- [WithStatement](#)
- [LabelledStatement](#)
- [SwitchStatement](#)
- [ThrowStatement](#)
- [TryStatement](#)

### Semantics

A *Statement* can be part of a *LabelledStatement*, which itself can be part of a *LabelledStatement*, and so on. The labels introduced this way are collectively referred to as the “current label set” when describing the semantics of individual statements. A *LabelledStatement* has no semantic meaning other than the introduction of a label to a *label set*. The label set of an *IterationStatement* or a *SwitchStatement* initially contains the single element **empty**. The label set of any other statement is initially empty.

### 12.1 Block

#### Syntax

*Block* :

{ *StatementList*<sub>opt</sub> }

*StatementList* :

- Statement*
- StatementList* *Statement*

#### Semantics

The production *Block* : { } is evaluated as follows:

1. Return (**normal**, **empty**, **empty**).

The production *Block* : { *StatementList* } is evaluated as follows:

1. [Create a new object as if by the expression `new Object\(\)` where `Object` is the standard built-in constructor with that name.](#)
2. [Add Result\(1\) to the front of the scope chain.](#)
3. [Perform Variable Instantiation \(Section 10.3.1\) on the top-level code of the \*Block\*. This only instantiates constants and functions but not variables.](#)
4. Evaluate *StatementList* using the augmented scope chain from step 2.
5. [Remove Result\(1\) from the front of the scope chain.](#)
6. Return Result(4).

NOTE 1

pratapL 7/4/2008 10:54 AM

Deleted: VariableStatement ..

pratapL 7/4/2008 10:55 AM

**Comment [37]:** Note this means that VariableStatements cannot be used as “pseudo-blocks”. This is a change from ES3.

pratapL 7/4/2008 10:59 AM

Deleted: 1

Note that if the *StatementList* does not contain any *VariableStatement* or *FunctionDeclaration* statements the creation of a new execution context on the scope chain may be skipped.

NOTE 2

No matter how control leaves the embedded *Block*, whether normally or by some form of abrupt completion or exception, the scope chain is always restored to its former state.

The production *StatementList* : *Statement* is evaluated as follows:

1. Evaluate *Statement*.
2. If an exception was thrown, return (**throw**, *V*, empty) where *V* is the exception. (Execution now proceeds as if no exception were thrown.)
3. Return Result(1).

The production *StatementList* : *StatementList* *Statement* is evaluated as follows:

1. Evaluate *StatementList*.
2. If Result(1) is an abrupt completion, return Result(1).
3. Evaluate *Statement*.
4. If an exception was thrown, return (**throw**, *V*, empty) where *V* is the exception. (Execution now proceeds as if no exception were thrown.)
5. If Result(3).value is **empty**, let *V* = Result(1).value, otherwise let *V* = Result(3).value.
6. Return (Result(3).type, *V*, Result(3).target).

**12.1.1 Usage Subset cautious Restrictions**

A *VariableStatement* within an execution context that is subset restricted to the *cautious* subset, may not occur as the *StatementList* of a *Block*. The occurrence of a *VariableStatement* in such a context must be treated as a syntax error.

**12.2 Variable statement**

**Syntax**

*VariableStatement* :

**var** *VariableDeclarationList* ;

*VariableDeclarationList* :

*VariableDeclaration*  
*VariableDeclarationList* , *VariableDeclaration*

*VariableDeclarationListNoIn* :

*VariableDeclarationNoIn*  
*VariableDeclarationListNoIn* , *VariableDeclarationNoIn*

*VariableDeclaration* :

*Identifier* *Initialiser*<sub>opt</sub>

*VariableDeclarationNoIn* :

*Identifier* *InitialiserNoIn*<sub>opt</sub>

*Initialiser* :

= *AssignmentExpression*

*InitialiserNoIn* :

= *AssignmentExpressionNoIn*

**Description**

If the variable statement occurs inside a *FunctionDeclaration*, the variables are defined with function-local scope in that function, as described in s10.1.3. Otherwise, they are defined with global scope (that is, they are created as members of the global object, as described in 10.1.3) using property attributes { **[[Writable]]**: **true**, **[[Enumerable]]**: **true**, **[[Flexible]]**: **false** }. Variables are created when the execution scope is entered.

pratapL 5/28/2008 11:23 PM

Deleted: DontDelete

A *Block* does not define a new execution scope [for variables](#). Only *Program* and *FunctionDeclaration* produce a new scope [for variables](#). Variables are initialised to **undefined** when created. A variable with an *Initialiser* is assigned the value of its *AssignmentExpression* when the *VariableStatement* is executed, not when the variable is created.

#### Semantics

The production *VariableStatement* : **var** *VariableDeclarationList* ; is evaluated as follows:

1. Evaluate *VariableDeclarationList*.
2. Return (**normal, empty, empty**).

The production *VariableDeclarationList* : *VariableDeclaration* is evaluated as follows:

1. Evaluate *VariableDeclaration*.

The production *VariableDeclarationList* : *VariableDeclarationList* , *VariableDeclaration* is evaluated as follows:

1. Evaluate *VariableDeclarationList*.
2. Evaluate *VariableDeclaration*.

The production *VariableDeclaration* : *Identifier* is evaluated as follows:

1. Return a string value containing the same sequence of characters as in the *Identifier*.

The production *VariableDeclaration* : *Identifier* *Initialiser* is evaluated as follows:

1. Evaluate *Identifier* as described in 11.1.2.
2. Evaluate *Initialiser*.
3. Call GetValue(Result(2)).
4. Call PutValue(Result(1), Result(3), **false**).
5. Return a string value containing the same sequence of characters as in the *Identifier*.

The production *Initialiser* : = *AssignmentExpression* is evaluated as follows:

1. Evaluate *AssignmentExpression*.
2. Return Result(1).

The *VariableDeclarationListNoIn*, *VariableDeclarationNoIn* and *InitialiserNoIn* productions are evaluated in the same manner as the *VariableDeclarationList*, *VariableDeclaration* and *Initialiser* productions except that the contained *VariableDeclarationListNoIn*, *VariableDeclarationNoIn*, *InitialiserNoIn* and *AssignmentExpressionNoIn* are evaluated instead of the contained *VariableDeclarationList*, *VariableDeclaration*, *Initialiser* and *AssignmentExpression*, respectively.

### 12.3 Empty Statement

#### Syntax

*EmptyStatement* :  
;

#### Semantics

The production *EmptyStatement* : ; is evaluated as follows:

1. Return (**normal, empty, empty**).

### 12.4 Expression Statement

#### Syntax

*ExpressionStatement* :  
[lookahead ∉ {**function**}] *Expression* ;

Note that an *ExpressionStatement* cannot start with an opening curly brace because that might make it ambiguous with a *Block*. Also, an *ExpressionStatement* cannot start with the **function** keyword because that might make it ambiguous with a *FunctionDeclaration*.

#### Semantics

The production *ExpressionStatement* : [lookahead  $\notin$  {**t**, **function**}] *Expression* ; is evaluated as follows:

1. Evaluate *Expression*.
2. Call GetValue(Result(1)).
3. Return (**normal**, Result(2), **empty**).

### 12.5 The if Statement

#### Syntax

*IfStatement* :

```
if ( Expression ) SubStatement else SubStatement
if ( Expression ) SubStatement
```

Each **else** for which the choice of associated **if** is ambiguous shall be associated with the nearest possible **if** that would otherwise have no corresponding **else**.

#### Semantics

The production *IfStatement* : **if** ( *Expression* ) *SubStatement* **else** *SubStatement* is evaluated as follows:

1. Evaluate *Expression*.
2. Call GetValue(Result(1)).
3. Call ToBoolean(Result(2)).
4. If Result(3) is **false**, go to step 7.
5. Evaluate the first *SubStatement*.
6. Return Result(5).
7. Evaluate the second *SubStatement*.
8. Return Result(7).

The production *IfStatement* : **if** ( *Expression* ) *SubStatement* is evaluated as follows:

1. Evaluate *Expression*.
2. Call GetValue(Result(1)).
3. Call ToBoolean(Result(2)).
4. If Result(3) is **false**, return (**normal**, **empty**, **empty**).
5. Evaluate *SubStatement*.
6. Return Result(5).

### 12.6 Iteration Statements

An iteration statement consists of a *header* (which consists of a keyword and a parenthesised control construct) and a *body* (which consists of a *Statement*).

#### Syntax

*IterationStatement* :

```
do SubStatement while ( Expression ) ;
while ( Expression ) SubStatement
for ( ExpressionNoInopt ; Expressionopt ; Expressionopt ) SubStatement
for ( var VariableDeclarationListNoIn ; Expressionopt ; Expressionopt ) SubStatement
for ( LeftHandSideExpression in Expression ) SubStatement
for ( var VariableDeclarationNoIn in Expression ) SubStatement
```

#### 12.6.1 The do-while Statement

The production **do** *SubStatement* **while** ( *Expression* ) ; is evaluated as follows:

1. Let *V* = **empty**.

2. Evaluate *SubStatement*.
3. If Result(2).value is not **empty**, let  $V = \text{Result}(2).\text{value}$ .
4. If Result(2).type is **continue** and Result(2).target is in the current label set, go to step 7.
5. If Result(2).type is **break** and Result(2).target is in the current label set, return (**normal**,  $V$ , **empty**).
6. If Result(2) is an abrupt completion, return Result(2).
7. Evaluate *Expression*.
8. Call GetValue(Result(7)).
9. Call ToBoolean(Result(8)).
10. If Result(9) is **true**, go to step 2.
11. Return (**normal**,  $V$ , **empty**);

#### 12.6.2 The while statement

The production *IterationStatement* : **while** ( *Expression* ) *SubStatement* is evaluated as follows:

1. Let  $V = \text{empty}$ .
2. Evaluate *Expression*.
3. Call GetValue(Result(2)).
4. Call ToBoolean(Result(3)).
5. If Result(4) is **false**, return (**normal**,  $V$ , **empty**).
6. Evaluate *SubStatement*.
7. If Result(6).value is not **empty**, let  $V = \text{Result}(6).\text{value}$ .
8. If Result(6).type is **continue** and Result(6).target is in the current label set, go to 2.
9. If Result(6).type is **break** and Result(6).target is in the current label set, return (**normal**,  $V$ , **empty**).
10. If Result(6) is an abrupt completion, return Result(6).
11. Go to step 2.

#### 12.6.3 The for Statement

The production *IterationStatement* : **for** ( *ExpressionNoIn<sub>opt</sub>* ; *Expression<sub>opt</sub>* ; *Expression<sub>opt</sub>* ) *SubStatement* is evaluated as follows:

1. If *ExpressionNoIn* is not present, go to step 4.
2. Evaluate *ExpressionNoIn*.
3. Call GetValue(Result(2)). (This value is not used.)
4. Let  $V = \text{empty}$ .
5. If the first *Expression* is not present, go to step 10.
6. Evaluate the first *Expression*.
7. Call GetValue(Result(6)).
8. Call ToBoolean(Result(7)).
9. If Result(8) is **false**, go to step 19.
10. Evaluate *SubStatement*.
11. If Result(10).value is not **empty**, let  $V = \text{Result}(10).\text{value}$
12. If Result(10).type is **break** and Result(10).target is in the current label set, go to step 19.
13. If Result(10).type is **continue** and Result(10).target is in the current label set, go to step 15.
14. If Result(10) is an abrupt completion, return Result(10).
15. If the second *Expression* is not present, go to step 5.
16. Evaluate the second *Expression*.
17. Call GetValue(Result(16)). (This value is not used.)
18. Go to step 5.
19. Return (**normal**,  $V$ , **empty**).

The production *IterationStatement* : **for** ( **var** *VariableDeclarationListNoIn* ; *Expression<sub>opt</sub>* ; *Expression<sub>opt</sub>* ) *SubStatement* is evaluated as follows:

1. Evaluate *VariableDeclarationListNoIn*.
2. Let  $V = \text{empty}$ .
3. If the first *Expression* is not present, go to step 8.
4. Evaluate the first *Expression*.
5. Call GetValue(Result(4)).
6. Call ToBoolean(Result(5)).



7. If Result(6) is **false**, go to step 17.
8. Evaluate *SubStatement*.
9. If Result(8).value is not **empty**, let V = Result(8).value.
10. If Result(8).type is **break** and Result(8).target is in the current label set, go to step 17.
11. If Result(8).type is **continue** and Result(8).target is in the current label set, go to step 13.
12. If Result(8) is an abrupt completion, return Result(8).
13. If the second *Expression* is not present, go to step 3.
14. Evaluate the second *Expression*.
15. Call GetValue(Result(14)). (This value is not used.)
16. Go to step 3.
17. Return (**normal**, V, **empty**).

pratapL 3/25/2008 1:13 AM  
**Deleted:** 14

#### 12.6.4 The **for-in** Statement

The production *IterationStatement* : **for** ( *LeftHandSideExpression* **in** *Expression* ) *SubStatement* is evaluated as follows:

1. Evaluate the *Expression*.
2. Call GetValue(Result(1)).
3. Call ToObject(Result(2)).
4. Let V = **empty**.
5. Get the name of the next property of Result(3) whose **[[Enumerable]]** attribute is **true**. If there is no such property, go to step 14.
6. Evaluate the *LeftHandSideExpression* ( it may be evaluated repeatedly).
7. Call PutValue(Result(6), Result(5), **false**).
8. Evaluate *SubStatement*.
9. If Result(8).value is not **empty**, let V = Result(8).value.
10. If Result(8).type is **break** and Result(8).target is in the current label set, go to step 14.
11. If Result(8).type is **continue** and Result(8).target is in the current label set, go to step 5.
12. If Result(8) is an abrupt completion, return Result(8).
13. Go to step 5.
14. Return (**normal**, V, **empty**).

pratapL 5/28/2008 11:25 PM  
**Deleted:** that doesn't have the DontEnum attribute

The production *IterationStatement* : **for** ( **var** *VariableDeclarationNoIn* **in** *Expression* ) *SubStatement* is evaluated as follows:

1. Evaluate *VariableDeclarationNoIn*.
2. Evaluate *Expression*.
3. Call GetValue(Result(2)).
4. Call ToObject(Result(3)).
5. Let V = **empty**.
6. Get the name of the next property of Result(4) whose **[[Enumerable]]** attribute is **true**. If there is no such property, go to step 15.
7. Evaluate Result(1) as if it were an Identifier; see 0 (yes, it may be evaluated repeatedly).
8. Call PutValue(Result(7), Result(6), **false**).
9. Evaluate *SubStatement*.
10. If Result(9).value is not **empty**, let V = Result(9).value.
11. If Result(9).type is **break** and Result(9).target is in the current label set, go to step 15.
12. If Result(9).type is **continue** and Result(9).target is in the current label set, go to step 6.
13. If Result(8) is an abrupt completion, return Result(8).
14. Go to step 6.
15. Return (**normal**, V, **empty**).

pratapL 5/28/2008 11:26 PM  
**Deleted:** that doesn't have the DontEnum attribute

pratapL 7/4/2008 10:07 AM  
**Comment [38]:** Fix this.

The mechanics of enumerating the properties (step 5 in the first algorithm, step 6 in the second) is implementation dependent. The order of enumeration is defined by the object. Properties of the object being enumerated may be deleted during enumeration. If a property that has not yet been visited during enumeration is deleted, then it will not be visited. If new properties are added to the object being enumerated during enumeration, the newly added properties are not guaranteed to be visited in the active enumeration.

pratapL 7/4/2008 10:07 AM  
**Comment [39]:** We considered specifying the enumeration order but there were too many issues with existing implementations that optimize the representation of arrays.

Enumerating the properties of an object includes enumerating properties of its prototype, and the prototype of the prototype, and so on, recursively; but a property of a prototype is not enumerated if it is “shadowed” because some previous object in the prototype chain has a property with the same name.

#### 12.6.4.1 Usage Subset *cautious Restrictions*

[The same restrictions apply as specified in section 11.13.1.1 except that the algorithm change for the first algorithm is:](#)

7. Call `PutValue(Result(6), Result(5), true)`.

[The change for the second algorithm is:](#)

8. Call `PutValue(Result(6), Result(5), true)`

### 12.7 The `continue` Statement

#### Syntax

*ContinueStatement* :

**continue** [no *LineTerminator* here] *Identifier*<sub>opt</sub> ;

#### Semantics

A program is considered syntactically incorrect if either of the following are true:

The program contains a **continue** statement without the optional *Identifier*, which is not nested, directly or indirectly (but not crossing function boundaries), within an *IterationStatement*.

The program contains a **continue** statement with the optional *Identifier*, where *Identifier* does not appear in the label set of an enclosing (but not crossing function boundaries) *IterationStatement*.

A *ContinueStatement* without an *Identifier* is evaluated as follows:

1. Return (**continue**, **empty**, **empty**).

A *ContinueStatement* with the optional *Identifier* is evaluated as follows:

1. Return (**continue**, **empty**, *Identifier*).

### 12.8 The `break` Statement

#### Syntax

*BreakStatement* :

**break** [no *LineTerminator* here] *Identifier*<sub>opt</sub> ;

#### Semantics

A program is considered syntactically incorrect if either of the following are true:

The program contains a **break** statement without the optional *Identifier*, which is not nested, directly or indirectly (but not crossing function boundaries), within an *IterationStatement* or a *SwitchStatement*.

The program contains a **break** statement with the optional *Identifier*, where *Identifier* does not appear in the label set of an enclosing (but not crossing function boundaries) *Statement*.

A *BreakStatement* without an *Identifier* is evaluated as follows:

1. Return (**break**, **empty**, **empty**).

A *BreakStatement* with an *Identifier* is evaluated as follows:

1. Return (**break**, **empty**, *Identifier*).

### 12.9 The `return` Statement

#### Syntax

*ReturnStatement* :

**return** [no *LineTerminator* here] *Expression*<sub>opt</sub> ;

#### Semantics

An ECMAScript program is considered syntactically incorrect if it contains a **return** statement that is not within a *FunctionBody*. A **return** statement causes a function to cease execution and return a value to the caller. If *Expression* is omitted, the return value is **undefined**. Otherwise, the return value is the value of *Expression*.

The production *ReturnStatement* : **return** [no *LineTerminator* here] *Expression*<sub>opt</sub> ; is evaluated as:

1. If the *Expression* is not present, return (**return**, **undefined**, **empty**).
2. Evaluate *Expression*.
3. Call GetValue(Result(2)).
4. Return (**return**, Result(3), **empty**).

### 12.10 The **with** Statement

#### Syntax

*WithStatement* :

**with** ( *Expression* ) *SubStatement*

#### Description

The **with** statement adds a computed object to the front of the scope chain of the current execution context, then executes a statement with this augmented scope chain, then restores the scope chain.

#### Semantics

The production *WithStatement* : **with** ( *Expression* ) *SubStatement* is evaluated as follows:

1. Evaluate *Expression*.
2. Call GetValue(Result(1)).
3. Call ToObject(Result(2)).
4. Add Result(3) to the front of the scope chain.
5. Evaluate *SubStatement* using the augmented scope chain from step 4.
6. Let *C* be Result(5). If an exception was thrown in step 5, let *C* be (**throw**, *V*, **empty**), where *V* is the exception. (Execution now proceeds as if no exception were thrown.)
7. Remove Result(3) from the front of the scope chain.
8. Return *C*.

#### NOTE

No matter how control leaves the embedded '*SubStatement*', whether normally or by some form of abrupt completion or exception, the scope chain is always restored to its former state.

#### [12.10.1 Usage Subset cautious Restrictions](#)

[An execution context that is subset restricted to the cautious subset, may not execute a \*WithStatement\*. The occurrence of a \*WithStatement\* in such a context should be treated as a syntax error.](#)

### 12.11 The **switch** Statement

#### Syntax

*SwitchStatement* :

**switch** ( *Expression* ) *CaseBlock*

*CaseBlock* :

```
{ CaseClausesopt }  
{ CaseClausesopt DefaultClause CaseClausesopt }
```

CaseClauses :

CaseClause  
CaseClauses CaseClause

CaseClause :

**case** Expression : StatementList<sub>opt</sub>

DefaultClause :

**default** : StatementList<sub>opt</sub>

#### Semantics

The production *SwitchStatement* : **switch** ( Expression ) CaseBlock is evaluated as follows:

1. Evaluate *Expression*.
2. Call GetValue(Result(1)).
3. Evaluate *CaseBlock*, passing it Result(2) as a parameter.
4. If Result(3).type is **break** and Result(3).target is in the current label set, return (**normal**, Result(3).value, **empty**).
5. Return Result(3).

The production CaseBlock : { CaseClauses<sub>opt</sub> } is given an input parameter, *input*, and is evaluated as follows:

1. Let *V* = **empty**.
2. Let *A* be the list of CaseClause items in source text order.
3. Let *C* be the next CaseClause in *A*. If there is no such CaseClause, then go to step 16.
4. Evaluate *C*.
5. If *input* is not equal to Result(4) as defined by the !== operator, then go to step 3.
6. If *C* does not have a StatementList, then go to step 10.
7. Evaluate *C*'s StatementList and let *R* be the result.
8. If *R* is an abrupt completion, then return *R*.
9. Let *V* = *R*.value.
10. Let *C* be the next CaseClause in *A*. If there is no such CaseClause, then go to step 16.
11. If *C* does not have a StatementList, then go to step 10.
12. Evaluate *C*'s StatementList and let *R* be the result.
13. If *R*.value is not **empty**, then let *V* = *R*.value.
14. If *R* is an abrupt completion, then return (*R*.type, *V*, *R*.target).
15. Go to step 10.
16. Return (**normal**, *V*, **empty**).

The production CaseBlock : { CaseClauses<sub>opt</sub> DefaultClause CaseClauses<sub>opt</sub> } is given an input parameter, *input*, and is evaluated as follows:

1. Let *V* = **empty**.
2. Let *A* be the list of CaseClause items in the first CaseClauses, in source text order.
3. Let *C* be the next CaseClause in *A*. If there is no such CaseClause, then go to step 11.
4. Evaluate *C*.
5. If *input* is not equal to Result(4) as defined by the !== operator, then go to step 3.
6. If *C* does not have a StatementList, then go to step 20.
7. Evaluate *C*'s StatementList and let *R* be the result.
8. If *R* is an abrupt completion, then return *R*.
9. Let *V* = *R*.value.
10. Go to step 20.
11. Let *B* be the list of CaseClause items in the second CaseClauses, in source text order.
12. Let *C* be the next CaseClause in *B*. If there is no such CaseClause, then go to step 26.
13. Evaluate *C*.
14. If *input* is not equal to Result(13) as defined by the !== operator, then go to step 12.
15. If *C* does not have a StatementList, then go to step 31.
16. Evaluate *C*'s StatementList and let *R* be the result.
17. If *R* is an abrupt completion, then return *R*.
18. Let *V* = *R*.value.

- 19. Go to step 31.
- 20. Let *C* be the next *CaseClause* in *A*. If there is no such *CaseClause*, then go to step 26.
- 21. If *C* does not have a *StatementList*, then go to step 20.
- 22. Evaluate *C*'s *StatementList* and let *R* be the result.
- 23. If *R.value* is not **empty**, then let *V* = *R.value*.
- 24. If *R* is an abrupt completion, then return (*R.type*, *V*, *R.target*).
- 25. Go to step 20.
- 26. If the *DefaultClause* does not have a *StatementList*, then go to step 30.
- 27. Evaluate the *DefaultClause*'s *StatementList* and let *R* be the result.
- 28. If *R.value* is not **empty**, then let *V* = *R.value*.
- 29. If *R* is an abrupt completion, then return (*R.type*, *V*, *R.target*).
- 30. Let *B* be the list of *CaseClause* items in the second *CaseClauses*, in source text order.
- 31. Let *C* be the next *CaseClause* in *B*. If there is no such *CaseClause*, then go to step 37.
- 32. If *C* does not have a *StatementList*, then go to step 31.
- 33. Evaluate *C*'s *StatementList* and let *R* be the result.
- 34. If *R.value* is not **empty**, then let *V* = *R.value*.
- 35. If *R* is an abrupt completion, then return (*R.type*, *V*, *R.target*).
- 36. Go to step 31.
- 37. Return (**normal**, *V*, **empty**).

The production *CaseClause* : **case** *Expression* : *StatementList*<sub>opt</sub> is evaluated as follows:

1. Evaluate *Expression*.
2. Call GetValue(Result(1)).
3. Return Result(2).

**NOTE**

Evaluating *CaseClause* does not execute the associated *StatementList*. It simply evaluates the *Expression* and returns the value, which the *CaseBlock* algorithm uses to determine which *StatementList* to start executing.

### 12.12 Labelled Statements

#### Syntax

*LabelledStatement* :

*Identifier* : *Statement*

#### Semantics

A *Statement* may be prefixed by a label. Labelled statements are only used in conjunction with labelled **break** and **continue** statements. ECMAScript has no **goto** statement.

An ECMAScript program is considered syntactically incorrect if it contains a *LabelledStatement* that is enclosed by a *LabelledStatement* with the same *Identifier* as label. This does not apply to labels appearing within the body of a *FunctionDeclaration* that is nested, directly or indirectly, within a labelled statement.

The production *Identifier* : *Statement* is evaluated by adding *Identifier* to the label set of *Statement* and then evaluating *Statement*. If the *LabelledStatement* itself has a non-empty label set, these labels are also added to the label set of *Statement* before evaluating it. If the result of evaluating *Statement* is (**break**, *V*, *L*) where *L* is equal to *Identifier*, the production results in (**normal**, *V*, **empty**).

Prior to the evaluation of a *LabelledStatement*, the contained *Statement* is regarded as possessing an empty label set, except if it is an *IterationStatement* or a *SwitchStatement*, in which case it is regarded as possessing a label set consisting of the single element, **empty**.

### 12.13 The throw statement

#### Syntax

*ThrowStatement* :

**throw** [no *LineTerminator* here] *Expression* ;

#### Semantics

pratapL 3/25/2008 1:40 AM  
 Deleted: The production *CaseBlock* : { *CaseClauses* *DefaultClause* *CaseClauses* } is given an input parameter, *input*, and is evaluated as follows: - ... [19]

The production *ThrowStatement* : **throw** [no *LineTerminator* here] *Expression* ; is evaluated as:

1. Evaluate *Expression*.
2. Call `GetValue(Result(1))`.
3. Return (**throw**, `Result(2)`, **empty**).

## 12.14 The **try** statement

### Syntax

*TryStatement* :

**try** *Block Catch*  
**try** *Block Finally*  
**try** *Block Catch Finally*

*Catch* :

**catch** (*Identifier*) *Block*

*Finally* :

**finally** *Block*

### Description

The **try** statement encloses a block of code in which an exceptional condition can occur, such as a runtime error or a **throw** statement. The **catch** clause provides the exception-handling code. When a catch clause catches an exception, its *Identifier* is bound to that exception.

### Semantics

The production *TryStatement* : **try** *Block Catch* is evaluated as follows:

1. Evaluate *Block*.
2. If `Result(1).type` is not **throw**, return `Result(1)`.
3. Evaluate *Catch* with parameter `Result(1)`.
4. Return `Result(3)`.

The production *TryStatement* : **try** *Block Finally* is evaluated as follows:

1. Evaluate *Block*.
2. Evaluate *Finally*.
3. If `Result(2).type` is **normal**, return `Result(1)`.
4. Return `Result(2)`.

The production *TryStatement* : **try** *Block Catch Finally* is evaluated as follows:

1. Evaluate *Block*.
2. Let *C* = `Result(1)`.
3. If `Result(1).type` is not **throw**, go to step 6.
4. Evaluate *Catch* with parameter `Result(1)`.
5. Let *C* = `Result(4)`.
6. Evaluate *Finally*.
7. If `Result(6).type` is **normal**, return *C*.
8. Return `Result(6)`.

The production *Catch* : **catch** (*Identifier*) *Block* is evaluated as follows:

1. Let *C* be the parameter that has been passed to this production.
2. Create a new object as if by the expression `new Object()` [where \*Object\* is the standard built-in constructor with that name](#).
3. Create a property in the object `Result(2)`. The property's name is *Identifier*, value is *C.value*, and attributes are { DontDelete }.
4. Add `Result(2)` to the front of the scope chain.
5. Evaluate *Block*.

pratapL 7/4/2008 11:12 AM

**Comment [40]:** Work still needs to be done to give catch blocks real lexical scoping.

pratapL 3/25/2008 1:15 AM

**Deleted:** If `Result(4).type` is not **normal**,

6. Remove Result(2) from the front of the scope chain.
7. Return Result(5).

The production *Finally* : **finally** *Block* is evaluated as follows:

1. Evaluate *Block*.
2. Return Result(1).

## 12.15 Constant statement

### Syntax

ConstantStatement :

**const** *ConstantDeclarationList* ;

ConstantDeclarationList :

ConstantDeclaration  
*ConstantDeclarationList* , *ConstantDeclaration*

ConstantDeclaration :

*Identifier Initialiser*

### Description

If the constant statement occurs inside a *FunctionDeclaration*, the constants are defined with function-local scope in that function, as described in §10.1.3. If a constant statement occurs inside a *Block*, the constants are defined with block-local scope. Otherwise, they are defined with global scope (that is, they are created as members of the global object, as described in 10.1.3) using property attributes { `[[Writable]]`: **true**, `[[Enumerable]]`: **true**, `[[Flexible]]`: **false** }. Constants are created when the execution scope is entered. Constants have no value when created. A constant is assigned the value of the *AssignmentExpression* of its *Initialiser* when the *ConstantStatement* is executed, not when the constant is created. Any attempts to access the value of a constant before it is assigned a value or to write to a constant throws a *ReferenceError* exception.

### Semantics

The production *ConstantStatement* : **const** *ConstantDeclarationList* ; is evaluated as follows:

1. Evaluate *ConstantDeclarationList*.
2. Return (**normal, empty, empty**).

The production *ConstantDeclarationList* ; *ConstantDeclaration* is evaluated as follows:

1. Evaluate *ConstantDeclaration*.

The production *ConstantDeclarationList* ; *ConstantDeclarationList* , *ConstantDeclaration* is evaluated as follows:

1. Evaluate *ConstantDeclarationList*.
2. Evaluate *ConstantDeclaration*.

The production *ConstantDeclaration* : *Identifier Initialiser* is evaluated as follows:

1. Evaluate *Identifier* as described in 11.1.2.
2. Evaluate *Initialiser*.
3. Call `GetValue(Result(2))`.
4. Call `GetBase(Result(1))`.
5. Call `GetPropertyNames(Result(1))`.
6. Call the `[[GetOwnProperty]]` method of `Result(4)` with argument `Result(5)`.
7. If `Result(6).[[Const]]` is not **Uninitialized** then throw a *SyntaxError* exception.
8. Update the own property *P* of `Result(4)` with attributes `[[Value]]`: `Result(2)` and `[[Const]]`: **Initialized**. This update is preformed irrespective of the current values of the properties `[[Writable]]` and `[[Flexible]]` attributes.

[9. Return a string value containing the same sequence of characters as in the Identifier.](#)

### 13 Function Definition

#### Syntax

*FunctionDeclaration* :

**function** *Identifier* ( *FormalParameterList<sub>opt</sub>* ) { *FunctionBody* }

*FunctionExpression* :

**function** *Identifier<sub>opt</sub>* ( *FormalParameterList<sub>opt</sub>* ) { *FunctionBody* }

*FormalParameterList* :

*Identifier*  
*FormalParameterList* , *Identifier*

*FunctionBody* :

*SourceElements*

#### Semantics

The production *FunctionDeclaration* : **function** *Identifier* ( *FormalParameterList<sub>opt</sub>* ) { *FunctionBody* } is processed for function declarations as follows:

1. Create a new Function object as specified in 13.2 with parameters specified by *FormalParameterList<sub>opt</sub>*, and body specified by *FunctionBody*. Pass in the scope chain of the running execution context as the *Scope*.
2. Create a property of the current variable object (as specified in 10.1.3) with name *Identifier* and value Result(1).

The production *FunctionExpression* : **function** ( *FormalParameterList<sub>opt</sub>* ) { *FunctionBody* } is evaluated as follows:

1. Create a new Function object as specified in 13.2 with parameters specified by *FormalParameterList<sub>opt</sub>* and body specified by *FunctionBody*. Pass in the scope chain of the running execution context as the *Scope*.
2. Return Result(1).

The production *FunctionExpression* : **function** *Identifier* ( *FormalParameterList<sub>opt</sub>* ) { *FunctionBody* } is evaluated as follows:

1. Create a new object as if by the expression **new Object()** [\\_where Object is the standard built-in constructor with that name.](#)
2. Add Result(1) to the front of the scope chain.
3. Create a new Function object as specified in 13.2 with parameters specified by *FormalParameterList<sub>opt</sub>* and body specified by *FunctionBody*. Pass in the scope chain of the running execution context as the *Scope*.
4. Create a property in the object Result(1). The property's name is *Identifier*, value is Result(3), and attributes are { **[[Writable]]: false, [[Enumerable]]: true, [[Flexible]]: false** }.
5. Remove Result(1) from the front of the scope chain.
6. Return Result(3).

#### NOTE

The *Identifier* in a *FunctionExpression* can be referenced from inside the *FunctionExpression*'s *FunctionBody* to allow the function to call itself recursively. However, unlike in a *FunctionDeclaration*, the *Identifier* in a *FunctionExpression* cannot be referenced from and does not affect the scope enclosing the *FunctionExpression*.

The production *FunctionBody* : *SourceElements* is evaluated as follows:

1. Process *SourceElements* for function declarations.
2. Evaluate *SourceElements*.
3. Return Result(2).

pratapL 3/25/2008 1:17 AM  
Deleted: 2

pratapL 7/4/2008 10:07 AM  
Comment [41]: Mark: is this observable?  
Lars: yes it is!

pratapL 5/28/2008 11:58 PM  
Deleted: DontDelete, ReadOnly



### 13.1 Definitions

[This section is no longer used.](#)

pratapL 7/3/2008 3:42 PM

Deleted: A couple of definitions are needed to describe the process of creating function objects:

pratapL 7/3/2008 3:42 PM

Deleted: - ... [20]

pratapL 5/29/2008 12:03 AM

Deleted: <#>If there already exists an object *E* that was created by an earlier call to this section's algorithm, and if that call to this section's algorithm was given a *FunctionBody* that is equated to the *FunctionBody* given now, then go to step 13. (If there is more than one object *E* satisfying these criteria, choose one at the implementation's discretion.) -

pratapL 7/2/2008 1:31 PM

Deleted: .

pratapL 6/18/2008 11:32 PM

Deleted: is given

pratapL 5/29/2008 12:05 AM

Deleted: DontEnum

pratapL 5/29/2008 12:05 AM

Deleted: <#>At the implementation's discretion, go to either step 2 or step 14. - ... [21]

pratapL 5/29/2008 12:06 AM

Deleted: Step 1 allows an implementation to optimise the common case of a function A that has a nested function B where B is not dependent on A. In this case the implementation is allowed to reuse the same object for B instead of creating a new one every time A is called. Step 13 makes this optimisation optional; an implementation that chooses not to implement it will go to step 2 ... [22]

### 13.2 Creating Function Objects

Given an optional parameter list specified by *FormalParameterList*, a body specified by *FunctionBody*, and a scope chain specified by *Scope*, a Function object is constructed as follows:

1. Create a new native ECMAScript object and let *F* be that object.
2. Set the `[[Class]]` property of *F* to "Function".
3. Set the `[[Prototype]]` property of *F* to the original Function prototype object as specified in 15.3.3.1.
4. Set the `[[Call]]` property of *F* as described in 13.2.1.
5. Set the `[[Construct]]` property of *F* as described in 13.2.2.
6. Set the `[[Scope]]` property of *F* to a new scope chain (10.1.4) that contains the same objects as *Scope*.
7. Set the `length` property of *F* to the number of formal properties specified in *FormalParameterList*. If no parameters are specified, set the `length` property of *F* to 0. This property is given attributes as specified in 15.3.5.1.
8. Set the `[[Extensible]]` property of *F* to true.
9. Create a new object as would be constructed by the expression `new Object()` where *Object* is the standard built-in constructor with that name.
10. Set the `constructor` property of Result(9) to *F*. This property has attributes { `[[Writable]]: true`, `[[Enumerable]]: false`, `[[Flexible]]: true` }.
11. Set the `prototype` property of *F* to Result(9). This property is given attributes as specified in 15.3.5.2.
12. Return *F*.

#### NOTE

A *prototype* property is automatically created for every function, to allow for the possibility that the function will be used as a constructor.

pratapL 7/2/2008 1:31 PM

Deleted: .

pratapL 6/18/2008 11:32 PM

Deleted: is given

pratapL 5/29/2008 12:05 AM

Deleted: DontEnum

pratapL 5/29/2008 12:05 AM

Deleted: <#>At the implementation's discretion, go to either step 2 or step 14. - ... [21]

pratapL 5/29/2008 12:06 AM

Deleted: Step 1 allows an implementation to optimise the common case of a function A that has a nested function B where B is not dependent on A. In this case the implementation is allowed to reuse the same object for B instead of creating a new one every time A is called. Step 13 makes this optimisation optional; an implementation that chooses not to implement it will go to step 2 ... [22]

#### 13.2.1 [[Call]]

When the `[[Call]]` property for a Function object *F* is called, the following steps are taken:

1. Establish a new execution context using *F*'s *FormalParameterList*, the passed arguments list, and the *this* value as described in 10.2.3.
2. Evaluate *F*'s *FunctionBody*.
3. Exit the execution context established in step 1, restoring the previous execution context.
4. If Result(2).type is **throw** then throw Result(2).value.
5. If Result(2).type is **return** then return Result(2).value.
6. (Result(2).type must be **normal**.) Return **undefined**.

#### 13.2.2 [[Construct]]

When the `[[Construct]]` property for a Function object *F* is called, the following steps are taken:

1. Create a new native ECMAScript object.
2. Set the `[[Class]]` property of Result(1) to "Object".
3. Set the `[[Extensible]]` property of Result(1) to true.
4. Get the value of the `prototype` property of *F*.
5. If Result(4) is an object, set the `[[Prototype]]` property of Result(1) to Result(4).
6. If Result(4) is not an object, set the `[[Prototype]]` property of Result(1) to the original Object prototype object as described in 15.2.3.1.
7. Invoke the `[[Call]]` property of *F*, providing Result(1) as the *this* value and providing the argument list passed into `[[Construct]]` as the argument values.
8. If Type(Result(7)) is **Object** then return Result(7).
9. Return Result(1).

pratapL 3/25/2008 1:18 AM

Deleted: the

pratapL 6/18/2008 11:35 PM

Deleted: 3

pratapL 6/18/2008 11:35 PM

Deleted: 3

pratapL 6/18/2008 11:35 PM

Deleted: 3

pratapL 7/4/2008 10:07 AM

Comment [42]: Herman Venter says: shouldn't this be "is an Object?"

pratapL 6/18/2008 11:35 PM

Deleted: 6

pratapL 6/18/2008 11:35 PM

Deleted: 6

## 14 Program

### Syntax

Program :

*UseSubsetDirective*<sub>opt</sub> *SourceElements*

*UseSubsetDirective*<sub>opt</sub> :

" use subset *SubsetList* " ;

*SubsetList* :

*Identifier*

*SubsetList* , *Identifier*

*SourceElements* :

*SourceElement*

*SourceElements* *SourceElement*

*SourceElement* :

*Statement*

### Semantics

The production *Program* : *UseSubsetDirective*<sub>opt</sub> *SourceElements* is evaluated as follows:

1. If the optional *UseSubsetDirective* is not present, the set of usage subsets for the *Program* is the empty set.
2. Else
  - a. Evaluate *SourceElements*.
3. The set of usage subsets for the *Program* is elements of the internal list that is Result(2a).
4. Process *SourceElements* for function declarations.
5. Evaluate *SourceElements*.
6. Return Result(5).

The production *SourceElements* : *SourceElement* is processed for function declarations as follows:

1. Process *SourceElement* for function declarations.

The production *SourceElements* : *SourceElement* is evaluated as follows:

1. Evaluate *SourceElement*.
2. Return Result(1).

The production *SourceElements* : *SourceElements* *SourceElement* is processed for function declarations as follows:

1. Process *SourceElements* for function declarations.
2. Process *SourceElement* for function declarations.

The production *SourceElements* : *SourceElements* *SourceElement* is evaluated as follows:

1. Evaluate *SourceElements*.
2. If Result(1) is an abrupt completion, return Result(1)
3. Evaluate *SourceElement*.
4. Return Result(3).

The production *SourceElement* : *Statement* is processed for function declarations by taking no action.

The production *SourceElement* : *Statement* is evaluated as follows:

1. Evaluate *Statement*.
2. Return Result(1).

The production *SourceElement* : *FunctionDeclaration* is processed for function declarations as follows:

Allen Wirfs-Brock 7/4/2008 10:07 AM

Comment [43]: Need to add semantics

pratapL 7/3/2008 3:43 PM

Deleted: ..

FunctionDeclaration

pratapL 7/3/2008 3:55 PM

Deleted: 2

1. Process *FunctionDeclaration* for function declarations (see clause 13).

The production *SourceElement* : *FunctionDeclaration* is evaluated as follows:

1. Return (**normal**, **empty**, **empty**).

The production *UseSubsetDirective<sub>opt</sub>* : " **use subset** *SubsetList* " ; is evaluated as follows:

1. Evaluate *SubsetList*
2. Return Result(1)

The production *SubsetList* : *Identifier* is evaluated as follows:

1. If *Identifier* is not the name of a usage subset that is supported by this ECMAScript implementation, return an empty internal list.
2. Return an internal list containing one element which is the *Identifier*.

The production *SubsetList* : *SubsetList* , *Identifier* is evaluated as follows:

1. Evaluate *SubsetList*.
2. If *Identifier* is not the name of a usage subset that is supported by this ECMAScript implementation, return Result(1)
3. If *Identifier* is already an element of Result(1), return Result(1)
4. Return an internal list whose length is one greater than the length of Result(1) and whose items are the items of Result(1), in order, followed at the end by *Identifier*, which is the last item of the new list.

DRAFT

## 15 Native ECMAScript Objects

There are certain built-in objects available whenever an ECMAScript program begins execution. One, the global object, is in the scope chain of the executing program. Others are accessible as initial properties of the global object.

Unless specified otherwise, the `[[Class]]` property of a built-in object is **"Function"** if that built-in object has a `[[Call]]` property, or **"Object"** if that built-in object does not have a `[[Call]]` property. [Unless specified otherwise, the `\[\[Extensible\]\]` property of a built-in object has the value \*\*true\*\*.](#)

Many built-in objects are functions: they can be invoked with arguments. Some of them furthermore are constructors: they are functions intended for use with the **new** operator. For each built-in function, this specification describes the arguments required by that function and properties of the Function object. For each built-in constructor, this specification furthermore describes properties of the prototype object of that constructor and properties of specific object instances returned by a **new** expression that invokes that constructor.

Unless otherwise specified in the description of a particular function, if a function or constructor described in this section is given fewer arguments than the function is specified to require, the function or constructor shall behave exactly as if it had been given sufficient additional arguments, each such argument being the **undefined** value.

Unless otherwise specified in the description of a particular function, if a function or constructor described in this section is given more arguments than the function is specified to allow, the [additional arguments are ignored](#).

### NOTE

*Implementations that add additional capabilities to the set of built-in functions are encouraged to do so by adding new functions rather than adding new parameters to existing functions.*

Every built-in function and every built-in constructor has the Function prototype object, which is the initial value of the expression **Function.prototype** (15.3.2.1), as the value of its internal `[[Prototype]]` property.

Every built-in prototype object has the Object prototype object, which is the initial value of the expression **Object.prototype** (15.3.2.1), as the value of its internal `[[Prototype]]` property, except the Object prototype object itself.

None of the built-in functions described in this section shall implement the internal `[[Construct]]` method unless otherwise specified in the description of a particular function. None of the built-in functions described in this section shall initially have a **prototype** property unless otherwise specified in the description of a particular function. Every built-in Function object described in this section—whether as a constructor, an ordinary function, or both—has a **length** property whose value is an integer. Unless otherwise specified, this value is equal to the largest number of named arguments shown in the section headings for the function description, including optional parameters.

### NOTE

*For example, the Function object that is the initial value of the `slice` property of the String prototype object is described under the section heading `"String.prototype.slice (start, end)"` which shows the two named arguments `start` and `end`; therefore the value of the `length` property of that Function object is 2.*

In every case, the **length** property of a built-in Function object described in this section has the attributes { `[[Writable]]`: **false**, `[[Enumerable]]`: **false**, `[[Flexible]]`: **false**, } (and no others). Every other property described in this section has the attribute { `[[Writable]]`: **true**, `[[Enumerable]]`: **false**, `[[Flexible]]`: **true**, } unless otherwise specified.

### 15.1 The Global Object

The global object does not have a `[[Construct]]` property; it is not possible to use the global object as a constructor with the **new** operator.

The global object does not have a `[[Call]]` property; it is not possible to invoke the global object as a function.

The values of the `[[Prototype]]` and `[[Class]]` properties of the global object are implementation-dependent.

pratapL 5/29/2008 12:10 AM

**Deleted:** behaviour of the function or constructor is undefined. In particular, an implementation is permitted (but not required) to throw a **TypeError** exception in this case

pratapL 7/4/2008 10:07 AM

**Comment [44]:** Breaking change!!  
Lars asks for the motivation of this change? Herman Venter says: I am not totally sure that this is OK, since the language was added before my time and presumably was required to allow either Navigator or IE to claim to be compliant with the standard while extending it. TODO: figure out if this issue is discussed anywhere.

pratapL 5/29/2008 12:11 AM

**Deleted:** **ReadOnly, DontDelete, DontEnum**

pratapL 5/29/2008 12:11 AM

**Deleted:** **DontEnum**

pratapL 5/29/2008 12:12 AM

**Deleted:** (and no others)

### 15.1.1 Value Properties of the Global Object

#### 15.1.1.1 NaN

The initial value of **NaN** is NaN (8.5). This property has the attributes { `[[Writable]]: false`, `[[Enumerable]]: false`, `[[Flexible]]: false` }.

#### 15.1.1.2 Infinity

The initial value of **Infinity** is  $+\infty$  (8.5). This property has the attributes { `[[Writable]]: false`, `[[Enumerable]]: false`, `[[Flexible]]: false` }.

#### 15.1.1.3 undefined

The initial value of **undefined** is **undefined** (8.1). This property has the attributes { `[[Writable]]: false`, `[[Enumerable]]: false`, `[[Flexible]]: false` }.

### 15.1.2 Function Properties of the Global Object

#### 15.1.2.1 eval (x)

When the **eval** function is called with one argument *x*, the following steps are taken:

1. If *x* is not a string value, return *x*.
2. Parse *x* as a *Program*. If the parse fails, throw a **SyntaxError** exception (but see also clause 16).
3. Evaluate the program from step 2.
4. If Result(3).type is **normal** and its completion value is a value *V*, then return the value *V*.
5. If Result(3).type is **normal** and its completion value is **empty**, then return the value **undefined**.
6. Result(3).type must be **throw**. Throw Result(3).value as an exception.

If the value of the **eval** property is used in any way other than a direct call (that is, other than by the explicit use of its name as an *Identifier* which is the *MemberExpression* in a *CallExpression*), or if the **eval** property is assigned to, an **EvalError** exception may be thrown.

##### 15.1.2.1.1 Usage Subset cautious Restrictions

If an execution context that is subset restricted to the cautious subset uses the value of the **eval** property any way other than a direct call (that is, other than by the explicit use of its name as an *Identifier* which is the *MemberExpression* in a *CallExpression*), or if the **eval** property is assigned to, an **EvalError** exception is thrown.

#### 15.1.2.2 parseInt (string , radix)

The **parseInt** function produces an integer value dictated by interpretation of the contents of the *string* argument according to the specified *radix*. Leading white space in the string is ignored. If *radix* is **undefined** or 0, it is assumed to be 10 except when the number begins with the character pairs **0x** or **0X**, in which case a radix of 16 is assumed. Any radix-16 number may also optionally begin with the character pairs **0x** or **0X**.

When the **parseInt** function is called, the following steps are taken:

1. Call ToString(*string*).
2. Let *S* be a newly created substring of Result(1) consisting of the first character that is not a *StrWhiteSpaceChar* and all characters following that character. (In other words, remove leading white space.)
3. Let *sign* be 1.
4. If *S* is not empty and the first character of *S* is a minus sign -, let *sign* be -1.
5. If *S* is not empty and the first character of *S* is a plus sign + or a minus sign -, then remove the first character from *S*.
6. Let *R* = ToInt32(*radix*).
7. If *R* = 0, go to step 11.
8. If *R* < 2 or *R* > 36, then return NaN.
9. If *R* = 16, go to step 13.
10. Go to step 14.
11. Let *R* = 10.
12. If the length of *S* is at least 1 and the first character of *S* is "0", then at the implementation's discretion either let *R* = 8 or leave *R* unchanged.

pratapL 7/4/2008 10:07 AM

**Comment [45]:** This is an intentional incompatible change from ES3.

pratapL 5/29/2008 12:14 AM

**Deleted:** DontEnum, DontDelete

pratapL 5/29/2008 12:15 AM

**Deleted:** DontEnum, DontDelete

pratapL 5/29/2008 12:15 AM

**Deleted:** DontEnum, DontDelete

pratapL 7/4/2008 11:15 AM

**Comment [46]:** From AWB: Need to do additional spec work to make eval act like an operator but without reserving the eval identifier.

13. If the length of *S* is at least 2 and the first two characters of *S* are either “0x” or “0X”, then remove the first two characters from *S* and let *R* = 16.
14. If *S* contains any character that is not a radix-*R* digit, then let *Z* be the substring of *S* consisting of all characters before the first such character; otherwise, let *Z* be *S*.
15. If *Z* is empty, return NaN.
16. Compute the mathematical integer value that is represented by *Z* in radix-*R* notation, using the letters **A-Z** and **a-z** for digits with values 10 through 35. (However, if *R* is 10 and *Z* contains more than 20 significant digits, every significant digit after the 20th may be replaced by a 0 digit, at the option of the implementation; and if *R* is not 2, 4, 8, 10, 16, or 32, then Result(16) may be an implementation-dependent approximation to the mathematical integer value that is represented by *Z* in radix-*R* notation.)
17. Compute the number value for Result(16).
18. Return *sign* × Result(17).

*NOTE*

**parseInt** may interpret only a leading portion of the string as an integer value; it ignores any characters that cannot be interpreted as part of the notation of an integer, and no indication is given that any such characters were ignored.

When radix is 0 or *undefined* and the string's number begins with a 0 digit not followed by an **x** or **X**, then the implementation may, at its discretion, interpret the number either as being octal or as being decimal. Implementations are encouraged to interpret numbers in this case as being decimal.

**15.1.2.3 parseInt (string)**

The **parseFloat** function produces a number value dictated by interpretation of the contents of the *string* argument as a decimal literal.

When the **parseFloat** function is called, the following steps are taken:

1. Call ToString(*string*).
2. Compute a substring of Result(1) consisting of the leftmost character that is not a *StrWhiteSpaceChar* and all characters to the right of that character. (In other words, remove leading white space.)
3. If neither Result(2) nor any prefix of Result(2) satisfies the syntax of a *StrDecimalLiteral* (see 0), return NaN.
4. Compute the longest prefix of Result(2), which might be Result(2) itself, which satisfies the syntax of a *StrDecimalLiteral*.
5. Return the number value for the MV of Result(4).

*NOTE*

**parseFloat** may interpret only a leading portion of the string as a number value; it ignores any characters that cannot be interpreted as part of the notation of a decimal literal, and no indication is given that any such characters were ignored.

**15.1.2.4 isNaN (number)**

Applies ToNumber to its argument, then returns **true** if the result is NaN, and otherwise returns **false**.

**15.1.2.5 isFinite (number)**

Applies ToNumber to its argument, then returns **false** if the result is NaN, +∞, or -∞, and otherwise returns **true**.

**15.1.3 URI Handling Function Properties**

Uniform Resource Identifiers, or URIs, are strings that identify resources (e.g. web pages or files) and transport protocols by which to access them (e.g. HTTP or FTP) on the Internet. The ECMAScript language itself does not provide any support for using URIs except for functions that encode and decode URIs as described in 15.1.3.1, 15.1.3.2, 15.1.3.3 and 15.1.3.4.

*NOTE*

Many implementations of ECMAScript provide additional functions and methods that manipulate web pages; these functions are beyond the scope of this standard.

pratapL 7/4/2008 10:07 AM  
Comment [47]: Fix this reference.

A URI is composed of a sequence of components separated by component separators. The general form is:

*Scheme* : *First* / *Second* ; *Third* ? *Fourth*

where the italicised names represent components and the “:”, “/”, “;” and “?” are reserved characters used as separators. The **encodeURI** and **decodeURI** functions are intended to work with complete URIs; they assume that any reserved characters in the URI are intended to have special meaning and so are not encoded. The **encodeURIComponent** and **decodeURIComponent** functions are intended to work with the individual component parts of a URI; they assume that any reserved characters represent text and so must be encoded so that they are not interpreted as reserved characters when the component is part of a complete URI.

The following lexical grammar specifies the form of encoded URIs.

```

uri :::
  uriCharactersopt

uriCharacters :::
  uriCharacter uriCharactersopt

uriCharacter :::
  uriReserved
  uriUnescaped
  uriEscaped

uriReserved ::: one of
  ; / ? : @ & = + $ ,

uriUnescaped :::
  uriAlpha
  DecimalDigit
  uriMark

uriEscaped :::
  % HexDigit HexDigit

uriAlpha ::: one of
  a b c d e f g h i j k l m n o p q r s t u v w x y z
  A B C D E F G H I J K L M N O P Q R S T U V W X Y Z

uriMark ::: one of
  - _ . ! ~ * ' ( )

```

When a character to be included in a URI is not listed above or is not intended to have the special meaning sometimes given to the reserved characters, that character must be encoded. The character is first transformed into a sequence of octets using the UTF-8 transformation, with surrogate pairs first transformed from their UCS-2 to UCS-4 encodings. (Note that for code points in the range [0,127] this results in a single octet with the same value.) The resulting sequence of octets is then transformed into a string with each octet represented by an escape sequence of the form “%xx”.

The encoding and escaping process is described by the hidden function Encode taking two string arguments *string* and *unescapedSet*. This function is defined for expository purpose only.

1. Compute the number of characters in *string*.
2. Let *R* be the empty string.
3. Let *k* be 0.
4. If *k* equals Result(1), return *R*.
5. Let *C* be the character at position *k* within *string*.
6. If *C* is not in *unescapedSet*, go to step 9.
7. Let *S* be a string containing only the character *C*.
8. Go to step 24.

9. If the code point value of  $C$  is not less than 0xDC00 and not greater than 0xDFFF, throw a **URIError** exception.
10. If the code point value of  $C$  is less than 0xD800 or greater than 0xDBFF, let  $V$  be the code point value of  $C$  and go to step 16.
11. Increase  $k$  by 1.
12. If  $k$  equals Result(1), throw a **URIError** exception.
13. Get the code point value of the character at position  $k$  within *string*.
14. If Result(13) is less than 0xDC00 or greater than 0xDFFF, throw a **URIError** exception.
15. Let  $V$  be  $((\text{the code point value of } C) - 0xD800) * 0x400 + (\text{Result}(13) - 0xDC00) + 0x10000$ .
16. Let *Octets* be the array of octets resulting by applying the UTF-8 transformation to  $V$ , and let  $L$  be the array size.
17. Let  $j$  be 0.
18. Get the value at position  $j$  within *Octets*.
19. Let  $S$  be a string containing three characters “%XY” where XY are two uppercase hexadecimal digits encoding the value of Result(18).
20. Let  $R$  be a new string value computed by concatenating the previous value of  $R$  and  $S$ .
21. Increase  $j$  by 1.
22. If  $j$  is equal to  $L$ , go to step 25.
23. Go to step 18.
24. Let  $R$  be a new string value computed by concatenating the previous value of  $R$  and  $S$ .
25. Increase  $k$  by 1.
26. Go to step 4.

The unescaping and decoding process is described by the hidden function Decode taking two string arguments *string* and *reservedSet*. This function is defined for expository purpose only.

1. Compute the number of characters in *string*.
2. Let  $R$  be the empty string.
3. Let  $k$  be 0.
4. If  $k$  equals Result(1), return  $R$ .
5. Let  $C$  be the character at position  $k$  within *string*.
6. If  $C$  is not ‘%’, go to step 40.
7. Let *start* be  $k$ .
8. If  $k + 2$  is greater than or equal to Result(1), throw a **URIError** exception.
9. If the characters at position  $(k+1)$  and  $(k + 2)$  within *string* do not represent hexadecimal digits, throw a **URIError** exception.
10. Let  $B$  be the 8-bit value represented by the two hexadecimal digits at position  $(k + 1)$  and  $(k + 2)$ .
11. Increment  $k$  by 2.
12. If the most significant bit in  $B$  is 0, let  $C$  be the character with code point value  $B$  and go to step 37.
13. Let  $n$  be the smallest non-negative number such that  $(B \ll n) \& 0x80$  is equal to 0.
14. If  $n$  equals 1 or  $n$  is greater than 4, throw a **URIError** exception.
15. Let *Octets* be an array of 8-bit integers of size  $n$ .
16. Put  $B$  into *Octets* at position 0.
17. If  $k + (3 * (n - 1))$  is greater than or equal to Result(1), throw a **URIError** exception.
18. Let  $j$  be 1.
19. If  $j$  equals  $n$ , go to step 29.
20. Increment  $k$  by 1.
21. If the character at position  $k$  is not ‘%’, throw a **URIError** exception.
22. If the characters at position  $(k + 1)$  and  $(k + 2)$  within *string* do not represent hexadecimal digits, throw a **URIError** exception.
23. Let  $B$  be the 8-bit value represented by the two hexadecimal digits at position  $(k + 1)$  and  $(k + 2)$ .
24. If the two most significant bits in  $B$  are not 10, throw a **URIError** exception.
25. Increment  $k$  by 2.
26. Put  $B$  into *Octets* at position  $j$ .
27. Increment  $j$  by 1.
28. Go to step 19.
29. Let  $V$  be the value obtained by applying the UTF-8 transformation to *Octets*, that is, from an array of octets into a 32-bit value.
30. If  $V$  is less than 0x10000, go to step 36.
31. If  $V$  is greater than 0x10FFFF, throw a **URIError** exception.



32. Let  $L$  be  $((V - 0x10000) \& 0x3FF) + 0xDC00$ .
33. Let  $H$  be  $((V - 0x10000) \gg 10) \& 0x3FF + 0xD800$ .
34. Let  $S$  be the string containing the two characters with code point values  $H$  and  $L$ .
35. Go to step 41.
36. Let  $C$  be the character with code point value  $V$ .
37. If  $C$  is not in *reservedSet*, go to step 40.
38. Let  $S$  be the substring of *string* from position *start* to position  $k$  included.
39. Go to step 41.
40. Let  $S$  be the string containing only the character  $C$ .
41. Let  $R$  be a new string value computed by concatenating the previous value of  $R$  and  $S$ .
42. Increase  $k$  by 1.
43. Go to step 4.

**NOTE 1**

The syntax of Uniform Resource Identifiers is given in RFC2396.

**NOTE 2**

A formal description and implementation of UTF-8 is given in the Unicode Standard, Version 2.0, Appendix A.

In UTF-8, characters are encoded using sequences of 1 to 6 octets. The only octet of a "sequence" of one has the higher-order bit set to 0, the remaining 7 bits being used to encode the character value. In a sequence of  $n$  octets,  $n > 1$ , the initial octet has the  $n$  higher-order bits set to 1, followed by a bit set to 0. The remaining bits of that octet contain bits from the value of the character to be encoded. The following octets all have the higher-order bit set to 1 and the following bit set to 0, leaving 6 bits in each to contain bits from the character to be encoded. The possible UTF-8 encodings of ECMAScript characters are:

Code Point Value	Representation	1 <sup>st</sup> Octet	2 <sup>nd</sup> Octet	3 <sup>rd</sup> Octet	4 <sup>th</sup> Octet
0x0000 - 0x007F	00000000 0zzzzzzz	0zzzzzzz			
0x0080 - 0x07FF	00000yyy yyzzzzzz	110yyyyy	10zzzzzz		
0x0800 - 0xD7FF	xxxxxyyy yyzzzzzz	1110xxxx	10yyyyyy	10zzzzzz	
0xD800 - 0xDBFF followed by 0xDC00 - 0xDFFF	110110vv vvvwwwww followed by 110111yy yyzzzzzz	11110uuu	10uuwww	10xyyyyy	10zzzzzz
0xD800 - 0xDBFF not followed by 0xDC00 - 0xDFFF	causes URIError				
0xDC00 - 0xDFFF	causes URIError				
0xE000 - 0xFFFF	xxxxxyyy yyzzzzzz	1110xxxx	10yyyyyy	10zzzzzz	

*Where*

$uuuuu = vvvv + 1$

to account for the addition of 0x10000 as in 3.7, Surrogates of the Unicode Standard version 2.0.

The range of code point values 0xD800-0xDFFF is used to encode surrogate pairs; the above transformation combines a UCS-2 surrogate pair into a UCS-4 representation and encodes the resulting 21-bit value in UTF-8. Decoding reconstructs the surrogate pair.

**15.1.3.1 decodeURI (encodedURI)**

The **decodeURI** function computes a new version of a URI in which each escape sequence and UTF-8 encoding of the sort that might be introduced by the **encodeURI** function is replaced with the

character that it represents. Escape sequences that could not have been introduced by **encodeURI** are not replaced.

When the **decodeURI** function is called with one argument *encodedURI*, the following steps are taken:

1. Call **ToString**(*encodedURI*).
2. Let *reservedURISet* be a string containing one instance of each character valid in *uriReserved* plus “#”.
3. Call **Decode**(**Result**(1), *reservedURISet*)
4. Return **Result**(3).

*NOTE*

The character “#” is not decoded from escape sequences even though it is not a reserved URI character.

**15.1.3.2 decodeURIComponent (encodedURIComponent)**

The **decodeURIComponent** function computes a new version of a URI in which each escape sequence and UTF-8 encoding of the sort that might be introduced by the **encodeURIComponent** function is replaced with the character that it represents.

When the **decodeURIComponent** function is called with one argument *encodedURIComponent*, the following steps are taken:

1. Call **ToString**(*encodedURIComponent*).
2. Let *reservedURIComponentSet* be the empty string.
3. Call **Decode**(**Result**(1), *reservedURIComponentSet*)
4. Return **Result**(3).

**15.1.3.3 encodeURI (uri)**

The **encodeURI** function computes a new version of a URI in which each instance of certain characters is replaced by one, two or three escape sequences representing the UTF-8 encoding of the character.

When the **encodeURI** function is called with one argument *uri*, the following steps are taken:

1. Call **ToString**(*uri*).
2. Let *unescapedURISet* be a string containing one instance of each character valid in *uriReserved* and *uriUnescaped* plus “#”.
3. Call **Encode**(**Result**(1), *unescapedURISet*)
4. Return **Result**(3).

*NOTE*

The character “#” is not encoded to an escape sequence even though it is not a reserved or unescaped URI character.

**15.1.3.4 encodeURIComponent (uriComponent)**

The **encodeURIComponent** function computes a new version of a URI in which each instance of certain characters is replaced by one, two or three escape sequences representing the UTF-8 encoding of the character.

When the **encodeURIComponent** function is called with one argument *uriComponent*, the following steps are taken:

1. Call **ToString**(*uriComponent*).
2. Let *unescapedURIComponentSet* be a string containing one instance of each character valid in *uriUnescaped*.
3. Call **Encode**(**Result**(1), *unescapedURIComponentSet*)
4. Return **Result**(3).

## 15.1.4 Constructor Properties of the Global Object

### 15.1.4.1 Object ( . . . )

See 15.2.1 and 15.2.2.

### 15.1.4.2 Function ( . . . )

See 15.3.1 and 15.3.2.

### 15.1.4.3 Array ( . . . )

See 15.4.1 and 15.4.2.

### 15.1.4.4 String ( . . . )

See 15.5.1 and 15.5.2.

### 15.1.4.5 Boolean ( . . . )

See 15.6.1 and 15.6.2.

### 15.1.4.6 Number ( . . . )

See 15.7.1 and 15.7.2.

### 15.1.4.7 Date ( . . . )

See 15.9.2.

### 15.1.4.8 RegExp ( . . . )

See 15.10.3 and 15.10.4.

### 15.1.4.9 Error ( . . . )

See 15.11.1 and 15.11.2.

### 15.1.4.10 EvalError ( . . . )

See 15.11.6.1.

### 15.1.4.11 RangeError ( . . . )

See 15.11.6.2.

### 15.1.4.12 ReferenceError ( . . . )

See 15.11.6.3.

### 15.1.4.13 SyntaxError ( . . . )

See 15.11.6.4.

### 15.1.4.14 TypeError ( . . . )

See 15.11.6.5.

### 15.1.4.15 URIError ( . . . )

See 15.11.6.6.

## 15.1.5 Other Properties of the Global Object

### 15.1.5.1 Math

See 15.8.

## 15.2 Object Objects

### 15.2.1 The Object Constructor Called as a Function

When `Object` is called as a function rather than as a constructor, it performs a type conversion.

#### 15.2.1.1 Object ( [ value ] )

When the `Object` function is called with no arguments or with one argument *value*, the following steps are taken:

1. If *value* is **null**, **undefined** or not supplied, create and return a new Object object exactly if the object constructor had been called with the same arguments (15.2.2.1).
2. Return `ToObject(value)`.

## 15.2.2 The Object Constructor

When **Object** is called as part of a **new** expression, it is a constructor that may create an object.

### 15.2.2.1 new Object ( [ value ] )

When the **Object** constructor is called with no arguments or with one argument *value*, the following steps are taken:

1. If *value* is not supplied, go to step 8.
2. If the type of *value* is not Object, go to step 5.
3. If the *value* is a native ECMAScript object, do not create a new object but simply return *value*.
4. If the *value* is a host object, then actions are taken and a result is returned in an implementation-dependent manner that may depend on the host object.
5. If the type of *value* is String, return `ToObject(value)`.
6. If the type of *value* is Boolean, return `ToObject(value)`.
7. If the type of *value* is Number, return `ToObject(value)`.
8. (The argument *value* was not supplied or its type was Null or Undefined.) Create a new native ECMAScript object.  
The `[[Prototype]]` property of the newly constructed object is set to the Object prototype object.  
The `[[Class]]` property of the newly constructed object is set to **"Object"**.  
The `[[Extensible]]` property of the newly constructed object is set to **true**.  
The newly constructed object has no `[[PrimitiveValue]]` property.
9. Return the newly created native object.

pratapL 7/4/2008 10:07 AM

**Comment [48]:** Deviations doc item 3.12 suggests removing this phrase.

## 15.2.3 Properties of the Object Constructor

The value of the internal `[[Prototype]]` property of the Object constructor is the Function prototype object.

Besides the internal properties and the **length** property (whose value is **1**), the Object constructor has the following properties:

### 15.2.3.1 Object.prototype

The initial value of **Object.prototype** is the Object prototype object (15.2.4).

This property has the attributes { `[[Writable]]: false`, `[[Enumerable]]: false`, `[[Flexible]]: false` }.

pratapL 7/2/2008 1:41 PM

**Deleted:** -

### 15.2.3.2 Object.getOwnProperty ( O, P )

When the static `getOwnProperty` function is called, the following steps are taken:

1. Call `ToObject(O)`.
2. If *P* is **undefined** or **null**, use the empty string, otherwise call `ToString(P)`.
3. Call the `[[GetOwnProperty]]` method of `Result(1)` with argument `Result(2)`.
4. Call `FromPropertyDescriptor`](`Result(3)`).
5. Return `Result(4)`.

pratapL 5/29/2008 12:17 AM

**Deleted:** DontEnum, DontDelete, ReadOnly

### 15.2.3.3 Object.getProperty ( O, P )

When the static `getProperty` function is called, the following steps are taken:

1. Call `ToObject(O)`.
2. If *P* is **undefined** or **null**, use the empty string, otherwise call `ToString(P)`.
3. Call the `[[GetOwnProperty]]` method of `Result(1)` with argument `Result(2)`.
4. Call `FromPropertyDescriptor`(`Result(3)`).
5. Return `Result(4)`.

### 15.2.3.4 Object.getOwnProperties ( O )

When the static `getOwnProperties` function is called, the following steps are taken:

1. Call `ToObject(O)`.
2. Create a new object as if by the expression `new Object()` where **Object** is the standard built-in constructor with that name.
3. For each named own property *P* of `Result(1)`, in insertion order
  - a. Call the `[[GetOwnProperty]]` method of `Result(1)` with *P*.

pratapL 7/4/2008 10:07 AM

**Comment [49]:** From AWB:  
Do we really want to specify this order?

- b. [Call FromPropertyDescriptor\(Result\(3a\)\).](#)
- c. [Call the \[\[Put\]\] method of Result\(2\) with arguments \(P, Result\(3b\)\).](#)
4. [Return Result\(2\).](#)

#### 15.2.3.5 [Object.getProperties \( O \)](#)

When the static [getProperties](#) function is called, the following steps are taken:

1. [Call ToObject\(O\).](#)
2. [Create a new object as if by the expression `new Object\(\)` where `Object` is the standard built-in constructor with that name.](#)
3. [For each named property \(whether own or inherited\) \*P\* of Result\(1\), in \[insertion order\]\(#\),](#)
  - a. [Call the \[\[GetProperty\]\] method of Result\(1\) with \*P\*.](#)
  - b. [Call FromPropertyDescriptor\(Result\(3a\)\).](#)
  - c. [Call the \[\[Put\]\] method of Result\(2\) with arguments \(P, Result\(3b\)\).](#)
4. [Return Result\(2\).](#)

#### 15.2.3.6 [Object.create \( O \)](#)

The [create](#) method creates a new object with a specified [prototype](#). When the static [create](#) method is called, the following steps are taken:

1. [If \*O\* is `null` use \*O\*, otherwise call \[ToObject\\(O\\)\]\(#\).](#)
2. [Create a new object as if by the expression `new Object\(\)` where `Object` is the standard built-in constructor with that name.](#)
3. [If Result\(1\) is not `null`, set the internal \[\[Prototype\]\] property of Result\(2\) to Result\(1\).](#)
4. [Return Result\(3\).](#)

#### 15.2.3.7 [Object.clone \( O \)](#)

The [clone](#) method creates a new object that has the same [prototype](#) as the object that is the argument. In addition, the new object has own properties that are copies of the own properties of *O*. When the static [clone](#) method is called, the following steps are taken:

1. [If \*O\* is `null` use \*O\*, otherwise call \[ToObject\\(O\\)\]\(#\).](#)
2. [If \*O\* is a host object return an implementation defined result.](#)
3. [Create a new object as if by the expression `new Object\(\)` where `Object` is the standard built-in constructor with that name.](#)
4. [If Result\(1\) is not `null`, set the internal \[\[Prototype\]\] property of Result\(2\) to Result\(1\).](#)
5. [Set the internal \[\[Class\]\], \[\[PrimitiveValue\]\], \[\[Construct\]\], and \[\[Call\]\] properties of Result\(3\) to the same state as the corresponding properties of \*O\*.](#)
6. [If \*O\* has implementations of any internal methods that are different from the standard implementation defined in section 8.6.2, provide those same methods implementations to Result\(3\).](#)
7. [For each named own property name \*P\* of \*O\*](#)
  - a. [Call the \[\[GetOwnProperty\]\] method of \*O\* with \*P\* as the argument.](#)
  - b. [Call the \[\[DefineOwnProperty\]\] method of Result\(3\) with arguments \*P\*, Result\(7a\), `true`.](#)
8. [If the internal \[\[Extensible\]\] property of \*O\* is `false`, set the internal \[\[Extensible\]\] property of Result\(3\) to `false`.](#)
9. [Return Result\(3\).](#)

#### 15.2.3.8 [Object.defineProperty \( O, P, Delta \)](#)

The [defineProperty](#) method is used to add own properties and/or update the attributes of existing own property of an object. When the static [defineProperty](#) method is called, the following steps are taken:

1. [Call \[ToObject\\(O\\)\]\(#\).](#)
2. [Call \[ToString\\(P\\)\]\(#\).](#)
3. [Call \[ToPropertyDescriptor\]\(#\) with \[Result\\(Delta\\)\]\(#\) as the argument.](#)
4. [Call the \[\[DefineOwnProperty\]\] method of Result\(1\) with arguments Result\(2\), Result\(3\), and `true`.](#)
5. [Return Result\(1\).](#)

#### 15.2.3.9 [Object.defineProperties \( O, DeltaMap \)](#)

The [defineProperties](#) method is used to add own properties and/or update the attributes of existing own properties of an object. When the static [defineProperties](#) method is called, the following steps are taken atomically:

pratapL 7/4/2008 10:07 AM

**Comment [50]:** From AWB:  
Really? BTW, what is the insertion order for built-in objects?

1. Call `ToObject(O)`.
2. Call `ToObject(DeltaMap)`.
3. For each named own property name *P* of `Result(2)`,
  - a. Call the `[[GetOwnProperty]]` method of `Result(2)` with *P* as the argument.
  - b. Call `ToPropertyDescriptor` with `Result(3a)` as the argument.
  - c. Call the `[[DefineOwnProperty]]` method of `Result(1)` with arguments *P*, `Result(3b)`, **true**.
4. Return `Result(1)`.

The above algorithm is specified as a set of sequential steps that include the possibility of an exception being thrown at various intermediate points. Rather than failing after a partial update of *O*, this function must be implemented such that it either atomically completes all property updates successfully or fails without making any update to the properties of object *O*.

#### 15.2.3.10 `Object.seal ( O )`

When the static seal function is called, the following steps are taken:

1. Call `ToObject(O)`.
2. For each named own property name *P* of `Result(1)`,
  - a. Call the `[[GetOwnProperty]]` method of `Result(1)` with *P*.
  - b. If `Result(2a).[[Flexible]]` is **true**, set `Result(2a).[[Flexible]]` to **false**.
  - c. Call the `[[DefineOwnProperty]]` method of `Result(1)` with *P*, `Result(2a)`, and **true** as arguments.
3. Set the internal `[[Extensible]]` property of `Result(1)` to **false**.
4. Return `Result(1)`.

The above algorithm is specified as a set of sequential steps that include the possibility of an exception being thrown at various intermediate points. Rather than failing after a partial update of *O*, this function must be implemented such that it either atomically completes all property updates successfully or fails without making any update to the properties of object *O*.

#### 15.2.3.11 `Object.const ( O )`

When the static const function is called, the following steps are taken:

1. Call `ToObject(O)`.
2. For each named own property name *P* of `Result(1)`,
  - a. Call the `[[GetOwnProperty]]` method of `Result(1)` with *P*.
  - b. If `IsDataDescriptor(Result(2a))` then
    - i. If `Result(2a).[[Writable]]` is true, set `result(2a).[[Writable]]` to **false**.
  - c. If `Result(2a).[[Flexible]]` is **true**, set `Result(2a).[[Flexible]]` to **false**.
  - d. Call the `[[DefineOwnProperty]]` method of `Result(1)` with *P*, `Result(2a)`, and **true** as arguments.
3. Set the internal `[[Extensible]]` property of `Result(1)` to **false**.
4. Return `Result(1)`.

The above algorithm is specified as a set of sequential steps that include the possibility of an exception being thrown at various intermediate points. Rather than failing after a partial update of *O*, this function must be implemented such that it either atomically completes all property updates successfully or fails without making any update to the properties of object *O*.

#### 15.2.3.12 `Object.isSealed ( O )`

When the `isSealed` function is called with argument *O*, the following steps are taken:

1. Call `ToObject(O)`.
2. For each named own data property *P* of `Result(1)`
  - a. Call the `[[GetOwnProperty]]` method of `Result(1)` with *P*.
  - b. If the `[[Flexible]]` field of `Result(2a)` is **true**, then return **false**.
3. If the internal `[[Extensible]]` property of `Result(1)` is **false**, then return **true**.
4. Otherwise, return **false**.

#### 15.2.3.13 `Object.isConst ( O )`

When the `isConst` function is called with argument *O*, the following steps are taken:

1. Call `ToObject(O)`.
2. For each named own data property name *P* of `Result(1)`
  - a. Call the `[[GetOwnProperty]]` method of `Result(1)` with *P*.
  - b. If `IsDataDescriptor(Result(2a))` then
    - i. If `Result(2a).[[Writable]]` is `true`, return `false`.
    - c. If the `[[Flexible]]` field of `Result(2a)` is `true`, then return `false`.
  3. If the internal `[[Extensible]]` property of `Result(1)` is `true`, then return `false`.
  4. Otherwise, return `true`.

#### 15.2.3.14 `Object.getPrototypeOf ( O )`

When the `getPrototypeOf` method is called with argument *O*, the following steps are taken:

1. Call `ToObject(O)`.
2. Return the `[[Prototype]]` property of `Result(1)`.

#### 15.2.4 Properties of the Object Prototype Object

The value of the internal `[[Prototype]]` property of the Object prototype object is `null`, the value of the internal `[[Class]]` property is `"Object"`, and the value of the internal `[[Extensible]]` property is `true`.

##### 15.2.4.1 `Object.prototype.constructor`

The initial value of `Object.prototype.constructor` is the built-in `Object` constructor.

##### 15.2.4.2 `Object.prototype.toString ( )`

When the `toString` method is called, the following steps are taken:

1. Get the `[[Class]]` property of this object.
2. Compute a string value by concatenating the three strings `"[object "`, `Result(1)`, and `"]"`.
3. Return `Result(2)`.

##### 15.2.4.3 `Object.prototype.toLocaleString ( )`

This function returns the result of calling `this.toString()`.

###### NOTE 1

This function is provided to give all Objects a generic `toLocaleString` interface, even though not all may use it. Currently, `Array`, `Number`, and `Date` provide their own locale-sensitive `toLocaleString` methods.

###### NOTE 2

The first parameter to this function is likely to be used in a future version of this standard; it is recommended that implementations do not use this parameter position for anything else.

##### 15.2.4.4 `Object.prototype.valueOf ( )`

The `valueOf` method returns its `this` value. If the object is the result of calling the `Object` constructor with a host object (15.2.2.1), it is implementation-defined whether `valueOf` returns its `this` value or another value such as the host object originally passed to the constructor.

##### 15.2.4.5 `Object.prototype.hasOwnProperty ( V )`

When the `hasOwnProperty` method is called with argument *V*, the following steps are taken:

1. Let *O* be this object.
2. Call `ToString(V)`.
3. If *O* doesn't have an `own` property with the name given by `Result(2)`, return `false`.
4. Return `true`.

###### NOTE

Unlike `[[HasProperty]]` (8.6.2.4), this method does not consider objects in the prototype chain.

##### 15.2.4.6 `Object.prototype.isPrototypeOf ( V )`

When the `isPrototypeOf` method is called with argument *V*, the following steps are taken:

1. Let *O* be this object.
2. If *V* is not an object, return `false`.

3. Let *V* be the value of the `[[Prototype]]` property of *V*.
4. if *V* is **null**, return **false**
5. If *O* and *V* refer to the same object, return **true**.
6. Go to step 3.

pratapL 5/29/2008 12:24 AM  
**Deleted:** or if they refer to objects joined to each other (13.1.2)

**15.2.4.7 Object.prototype.propertyIsEnumerable (V)**

When the `propertyIsEnumerable` method is called with argument *V*, the following steps are taken:

1. Let *O* be this object.
2. Call `ToString(V)`.
3. If *O* doesn't have a property with the name given by `Result(2)`, return **false**.
4. Return the value of the property's `[[Enumerable]]` attribute.

pratapL 5/29/2008 12:26 AM  
**Deleted:** <#-If the property has the DontEnum attribute, return **false**.

*NOTE*  
 This method does not consider objects in the prototype chain.

pratapL 5/29/2008 12:27 AM  
**Deleted:** true

**15.2.5 Properties of Object Instances**

Object instances have no special properties beyond those inherited from the Object prototype object.

**15.3 Function Objects**

**15.3.1 The Function Constructor Called as a Function**

When `Function` is called as a function rather than as a constructor, it creates and initialises a new Function object. Thus the function call `Function(...)` is equivalent to the object creation expression `new Function(...)` with the same arguments.

**15.3.1.1 Function (p1, p2, ... , pn, body)**

When the `Function` function is called with some arguments *p1*, *p2*, ... , *pn*, *body* (where *n* might be 0, that is, there are no "p" arguments, and where *body* might also not be provided), the following steps are taken:

1. Create and return a new Function object as if the [standard built-in constructor Function was used in a new expression](#) with the same arguments (15.3.2.1).

pratapL 6/30/2008 8:18 PM  
**Deleted:** function

**15.3.2 The Function Constructor**

When `Function` is called as part of a `new` expression, it is a constructor: it initialises the newly created object.

pratapL 6/30/2008 8:19 PM  
**Deleted:** had been called

**15.3.2.1 new Function (p1, p2, ... , pn, body)**

The last argument specifies the body (executable code) of a function; any preceding arguments specify formal parameters.

When the `Function` constructor is called with some arguments *p1*, *p2*, ... , *pn*, *body* (where *n* might be 0, that is, there are no "p" arguments, and where *body* might also not be provided), the following steps are taken:

1. Let *P* be the empty string.
2. If no arguments were given, let *body* be the empty string and go to step 13.
3. If one argument was given, let *body* be that argument and go to step 13.
4. Let `Result(4)` be the first argument.
5. Let *P* be `ToString(Result(4))`.
6. Let *k* be 2.
7. If *k* equals the number of arguments, let *body* be the *k*<sup>th</sup> argument and go to step 13.
8. Let `Result(8)` be the *k*<sup>th</sup> argument.
9. Call `ToString(Result(8))`.
10. Let *P* be the result of concatenating the previous value of *P*, the string ", " (a comma), and `Result(9)`.
11. Increase *k* by 1.
12. Go to step 7.
13. Call `ToString(body)`.



14. If *P* is not parsable as a *FormalParameterList<sub>opt</sub>* then throw a **SyntaxError** exception.
15. If *body* is not parsable as *FunctionBody* then throw a **SyntaxError** exception.
16. Create a new Function object as specified in 13.2 with parameters specified by parsing *P* as a *FormalParameterList<sub>opt</sub>* and body specified by parsing *body* as a *FunctionBody*. Pass in a scope chain consisting of the global object as the *Scope* parameter.
17. Return Result(16).

A **prototype** property is automatically created for every function, to provide for the possibility that the function will be used as a constructor.

*NOTE*

*It is permissible but not necessary to have one argument for each formal parameter to be specified. For example, all three of the following expressions produce the same result:*

```

new Function("a", "b", "c", "return a+b+c")

new Function("a, b, c", "return a+b+c")

new Function("a,b", "c", "return a+b+c")

```

**15.3.3 Properties of the Function Constructor**

The value of the internal `[[Prototype]]` property of the Function constructor is the Function prototype object (15.3.4).

[The value of the internal `\[\[Extensible\]\]` property of the Function constructor is true.](#) The Function constructor has the following properties:

**15.3.3.1 Function.prototype**

The initial value of `Function.prototype` is the Function prototype object (15.3.4).

This property has the attributes { `[[Writable]]: false`, `[[Enumerable]]: false`, `[[Flexible]]: false` }.

**15.3.3.2 Function.length**

[This is a data property with an initial value of 1.](#) This property has the attributes { `[[Writable]]: false`, `[[Enumerable]]: false`, `[[Flexible]]: false` }.

**15.3.4 Properties of the Function Prototype Object**

The Function prototype object is itself a Function object (its `[[Class]]` is `"Function"`) that, when invoked, accepts any arguments and returns **undefined**.

The value of the internal `[[Prototype]]` property of the Function prototype object is the Object prototype object (15.3.2.1). [The value of the internal `\[\[Extensible\]\]` property of the Function prototype object is true.](#)

It is a function with an “empty body”; if it is invoked, it merely returns **undefined**.

The Function prototype object does not have a `valueOf` property of its own; however, it inherits the `valueOf` property from the Object prototype Object.

**15.3.4.1 Function.prototype.constructor**

The initial value of `Function.prototype.constructor` is the built-in `Function` constructor.

**15.3.4.2 Function.prototype.toString ( )**

An implementation-dependent representation of the function is returned. This representation has the syntax of a *FunctionDeclaration*. Note in particular that the use and placement of white space, line terminators, and semicolons within the representation string is implementation-dependent.

The `toString` function is not generic; it throws a **TypeError** exception if its `this` value is not a Function object. Therefore, it cannot be transferred to other kinds of objects for use as a method.

pratapL 6/24/2008 4:44 PM  
**Deleted:** Besides the internal properties and the `length` property (whose value is 1), the

pratapL 5/29/2008 12:28 AM  
**Deleted:** DontEnum, DontDelete, ReadOnly

### 15.3.4.3 Function.prototype.apply (thisArg, argArray)

The **apply** method takes two arguments, *thisArg* and *argArray*, and performs a function call using the `[[Call]]` property of the object. If the object does not have a `[[Call]]` property, a **TypeError** exception is thrown.

If *thisArg* is **null** or **undefined**, the called function is passed the global object as the **this** value. Otherwise, the called function is passed `ToObject(thisArg)` as the **this** value.

If *argArray* is **null** or **undefined**, the called function is passed no arguments. Otherwise, if *argArray* is neither an array nor an arguments object (see 10.1.8), a **TypeError** exception is thrown. If *argArray* is either an array or an arguments object, the function is passed the `(ToUint32(argArray.length))` arguments *argArray*[0], *argArray*[1], ..., *argArray*[`ToUint32(argArray.length)-1`].

The **length** property of the **apply** method is 2.

### 15.3.4.4 Function.prototype.call (thisArg [, arg1 [, arg2, ... ]])

The **call** method takes one or more arguments, *thisArg* and (optionally) *arg1*, *arg2* etc, and performs a function call using the `[[Call]]` property of the object. If the object does not have a `[[Call]]` property, a **TypeError** exception is thrown. The called function is passed *arg1*, *arg2*, etc. as the arguments.

If *thisArg* is **null** or **undefined**, the called function is passed the global object as the **this** value. Otherwise, the called function is passed `ToObject(thisArg)` as the **this** value.

The **length** property of the **call** method is 1.

### 15.3.4.5 Function.prototype.bind (thisArg [, arg1 [, arg2, ...]])

The **bind** method takes one or more arguments, *thisArg* and (optionally) *arg1*, *arg2*, etc, and wraps the function in another, locking its execution scope to the object specified by *thisArg*. If additional arguments are provided, then they are **curried**.

The **length** data property of the **bind** method has the value 1.

pratapL 7/4/2008 10:07 AM  
**Comment [51]:** From AWB:  
Needs a more precise specification.

### 15.3.5 Properties of Function Instances

In addition to the required internal properties, every function instance has a `[[Call]]` property, a `[[Construct]]` property and a `[[Scope]]` property (see 8.6.2 and 13.2). The value of the `[[Class]]` property is **"Function"**.

#### 15.3.5.1 length

The value of the **length** property is usually an integer that indicates the "typical" number of arguments expected by the function. However, the language permits the function to be invoked with some other number of arguments. The behaviour of a function when invoked on a number of arguments other than the number specified by its **length** property depends on the function. This property has the attributes { `[[Writable]]`: **false**, `[[Enumerable]]`: **false**, `[[Flexible]]`: **false** }.

pratapL 5/29/2008 12:28 AM  
**Deleted:** DontDelete, ReadOnly, DontEnum

#### 15.3.5.2 prototype

The value of the **prototype** property is used to initialise the internal `[[Prototype]]` property of a newly created object before the Function object is invoked as a constructor for that newly created object. This property has the attribute { `[[Writable]]`: **true**, `[[Enumerable]]`: **true**, `[[Flexible]]`: **false** }.

pratapL 5/29/2008 12:29 AM  
**Deleted:** DontDelete

#### 15.3.5.3 [[HasInstance]] (V)

Assume *F* is a Function object.

When the `[[HasInstance]]` method of *F* is called with value *V*, the following steps are taken:

1. If *V* is not an object, return **false**.
2. Call the `[[Get]]` method of *F* with property name **"prototype"**.
3. Let *O* be `Result(2)`.
4. If *O* is not an object, throw a **TypeError** exception.
5. Let *V* be the value of the `[[Prototype]]` property of *V*.
6. If *V* is **null**, return **false**.
7. If *O* and *V* refer to the same object, return **true**.
8. Go to step 5.

pratapL 5/29/2008 12:30 AM  
**Deleted:** or if they refer to objects joined to each other (13.1.2)

## 15.4 Array Objects

Array objects give special treatment to a certain class of property names. A property name *P* (in the form of a string value) is an *array index* if and only if ToString(ToUint32(*P*)) is equal to *P* and ToUint32(*P*) is not equal to  $2^{32}-1$ . Every Array object has a **length** property whose value is always a nonnegative integer less than  $2^{32}$ . The value of the **length** property is numerically greater than the name of every property whose name is an array index; whenever a property of an Array object is created or changed, other properties are adjusted as necessary to maintain this invariant. Specifically, whenever a property is added whose name is an array index, the **length** property is changed, if necessary, to be one more than the numeric value of that array index; and whenever the **length** property is changed, every property whose name is an array index whose value is not smaller than the new length is automatically deleted. This constraint applies only to properties of the Array object itself and is unaffected by **length** or array index properties that may be inherited from its prototype.

### 15.4.1 The Array Constructor Called as a Function

When **Array** is called as a function rather than as a constructor, it creates and initialises a new Array object. Thus the function call **Array(...)** is equivalent to the object creation expression **new Array(...)** with the same arguments.

#### 15.4.1.1 Array ( [ item1 [ , item2 [ , ... ] ] ] )

When the **Array** function is called the following steps are taken:

1. Create and return a new Array object exactly as if the [standard built-in constructor Array](#) was used in a [new expression](#) with the same arguments (15.4.2).

### 15.4.2 The Array Constructor

When **Array** is called as part of a **new** expression, it is a constructor: it initialises the newly created object.

#### 15.4.2.1 new Array ( [ item0 [ , item1 [ , ... ] ] ] )

This description applies if and only if the Array constructor is given no arguments or at least two arguments.

The `[[Prototype]]` property of the newly constructed object is set to the original Array prototype object, the one that is the initial value of **Array.prototype** (15.4.3.1).

The `[[Class]]` property of the newly constructed object is set to **"Array"**.

[The `\[\[Extensible\]\]` property of the newly constructed object is set to \*\*true\*\*.](#)

The **length** property of the newly constructed object is set to the number of arguments.

The **0** property of the newly constructed object is set to *item0* (if supplied); the **1** property of the newly constructed object is set to *item1* (if supplied); and, in general, for as many arguments as there are, the *k* property of the newly constructed object is set to argument *k*, where the first argument is considered to be argument number 0.

#### 15.4.2.2 new Array (len)

The `[[Prototype]]` property of the newly constructed object is set to the original Array prototype object, the one that is the initial value of **Array.prototype** (15.4.3.1). The `[[Class]]` property of the newly constructed object is set to **"Array"**. [The `\[\[Extensible\]\]` property of the newly constructed object is set to \*\*true\*\*.](#)

If the argument *len* is a Number and ToUint32(*len*) is equal to *len*, then the **length** property of the newly constructed object is set to ToUint32(*len*). If the argument *len* is a Number and ToUint32(*len*) is not equal to *len*, a **RangeError** exception is thrown.

If the argument *len* is not a Number, then the **length** property of the newly constructed object is set to **1** and the **0** property of the newly constructed object is set to *len*.

pratapL 7/2/2008 1:54 PM
Deleted: array
pratapL 7/2/2008 1:55 PM
Deleted: had been called

### 15.4.3 Properties of the Array Constructor

The value of the internal `[[Prototype]]` property of the Array constructor is the Function prototype object (15.3.4).

Besides the internal properties and the `length` property (whose value is `1`), the Array constructor has the following properties:

#### 15.4.3.1 `Array.prototype`

The initial value of `Array.prototype` is the Array prototype object (15.4.4).

This property has the attributes `{ [[Writable]]: false, [[Enumerable]]: false, [[Flexible]]: false }`.

#### 15.4.3.2 `Array.isArray ( arg )`

The `isArray` function takes one argument `arg`, and returns the Boolean value `true` if the argument is determined to be an Array; otherwise it return `false`.

pratapL 5/29/2008 12:31 AM  
Deleted: DontEnum, DontDelete, ReadOnly

### 15.4.4 Properties of the Array Prototype Object

The value of the internal `[[Prototype]]` property of the Array prototype object is the Object prototype object (15.2.3.1).

The Array prototype object is itself an array; its `[[Class]]` is `"Array"`, and it has a `length` property (whose initial value is `+0`) and the special internal `[[ThrowablePut]]` method described in 15.2.3.1.

In following descriptions of functions that are properties of the Array prototype object, the phrase "this object" refers to the object that is the `this` value for the invocation of the function. It is permitted for the `this` to be an object for which the value of the internal `[[Class]]` property is not `"Array"`.

#### NOTE

The Array prototype object does not have a `valueOf` property of its own; however, it inherits the `valueOf` property from the Object prototype Object.

#### 15.4.4.1 `Array.prototype.constructor`

The initial value of `Array.prototype.constructor` is the built-in `Array` constructor.

#### 15.4.4.2 `Array.prototype.toString ( )`

The result of calling this function is the same as if the `standard` built-in `method Array.prototype.join` were invoked for this object with no argument.

The `toString` function is not generic; it throws a `TypeError` exception if its `this` value is not an Array object. Therefore, it cannot be transferred to other kinds of objects for use as a method.

pratapL 7/2/2008 1:56 PM  
Deleted: method

#### 15.4.4.3 `Array.prototype.toLocaleString ( )`

The elements of the array are converted to strings using their `toLocaleString` methods, and these strings are then concatenated, separated by occurrences of a separator string that has been derived in an implementation-defined locale-specific way. The result of calling this function is intended to be analogous to the result of `toString`, except that the result of this function is intended to be locale-specific.

The result is calculated as follows:

1. Call the `[[Get]]` method of this object with argument `"length"`.
2. Call `ToUint32(Result(1))`.
3. Let `separator` be the list-separator string appropriate for the host environment's current locale (this is derived in an implementation-defined way).
4. Call `Tostring(separator)`.
5. If `Result(2)` is zero, return the empty string.
6. Call the `[[Get]]` method of this object with argument `"0"`.
7. If `Result(6)` is `undefined` or `null`, use the empty string; otherwise, call `ToObject(Result(6)).toLocaleString()`.
8. Let `R` be `Result(7)`.
9. Let `k` be `1`.
10. If `k` equals `Result(2)`, return `R`.
11. Let `S` be a string value produced by concatenating `R` and `Result(4)`.

12. Call the `[[Get]]` method of this object with argument `ToString(k)`.
13. If `Result(12)` is **undefined** or **null**, use the empty string; otherwise, call `ToObject(Result(12)).toLocaleString()`.
14. Let *R* be a string value produced by concatenating *S* and `Result(13)`.
15. Increase *k* by 1.
16. Go to step 10.

The `toLocaleString` function is not generic; it throws a **TypeError** exception if its **this** value is not an `Array` object. Therefore, it cannot be transferred to other kinds of objects for use as a method.

*NOTE*

*The first parameter to this function is likely to be used in a future version of this standard; it is recommended that implementations do not use this parameter position for anything else.*

#### 15.4.4.4 `Array.prototype.concat` ( [ *item1* [ , *item2* [ , ... ] ] ] )

When the `concat` method is called with zero or more arguments *item1*, *item2*, etc., it returns an array containing the array elements of the object followed by the array elements of each argument in order.

The following steps are taken:

1. Let *A* be a new array created as if by the expression `new Array()` [where `Array` is the standard built-in constructor with that name.](#)
2. Let *n* be 0.
3. Let *E* be this object.
4. If *E* is not an `Array` object, go to step 16.
5. Let *k* be 0.
6. Call the `[[Get]]` method of *E* with argument `"length"`.
7. If *k* equals `Result(6)` go to step 19.
8. Call `ToString(k)`.
9. If *E* has a property named by `Result(8)`, go to step 10, but if *E* has no property named by `Result(8)`, go to step 13.
10. Call `ToString(n)`.
11. Call the `[[Get]]` method of *E* with argument `Result(8)`.
12. Call the `[[Put]]` method of *A* with arguments `Result(10)` and `Result(11)`.
13. Increase *n* by 1.
14. Increase *k* by 1.
15. Go to step 7.
16. Call `ToString(n)`.
17. Call the `[[Put]]` method of *A* with arguments `Result(16)` and *E*.
18. Increase *n* by 1.
19. Get the next argument in the argument list; if there are no more arguments, go to step 22.
20. Let *E* be `Result(19)`.
21. Go to step 4.
22. Call the `[[Put]]` method of *A* with arguments `"length"` and *n*.
23. Return *A*.

The `length` property of the `concat` method is **1**.

*NOTE*

*The `concat` function is intentionally generic; it does not require that its **this** value be an `Array` object. Therefore it can be transferred to other kinds of objects for use as a method. Whether the `concat` function can be applied successfully to a host object is implementation-dependent.*

#### 15.4.4.5 `Array.prototype.join` (*separator*)

The elements of the array are converted to strings, and these strings are then concatenated, separated by occurrences of the *separator*. If no *separator* is provided, a single comma is used as the *separator*.

The `join` method takes one argument, *separator*, and performs the following steps:

1. Call the `[[Get]]` method of this object with argument `"length"`.
2. Call `ToUint32(Result(1))`.

3. If *separator* is **undefined**, let *separator* be the single-character string `" , "`.
4. Call `ToString(separator)`.
5. If `Result(2)` is zero, return the empty string.
6. Call the `[[Get]]` method of this object with argument `"0"`.
7. If `Result(6)` is **undefined** or **null**, use the empty string; otherwise, call `ToString(Result(6))`.
8. Let *R* be `Result(7)`.
9. Let *k* be `1`.
10. If *k* equals `Result(2)`, return *R*.
11. Let *S* be a string value produced by concatenating *R* and `Result(4)`.
12. Call the `[[Get]]` method of this object with argument `ToString(k)`.
13. If `Result(12)` is **undefined** or **null**, use the empty string; otherwise, call `ToString(Result(12))`.
14. Let *R* be a string value produced by concatenating *S* and `Result(13)`.
15. Increase *k* by `1`.
16. Go to step 10.

The **length** property of the `join` method is `1`.

*NOTE*

The `join` function is intentionally generic; it does not require that its *this* value be an Array object. Therefore, it can be transferred to other kinds of objects for use as a method. Whether the `join` function can be applied successfully to a host object is implementation-dependent.

#### 15.4.4.6 Array.prototype.pop ( )

The last element of the array is removed from the array and returned.

1. Call the `[[Get]]` method of this object with argument `"length"`.
2. Call `ToUint32(Result(1))`.
3. If `Result(2)` is not zero, go to step 6.
4. Call the `[[Put]]` method of this object with arguments `"length"` and `Result(2)`.
5. Return **undefined**.
6. Call `ToString(Result(2)-1)`.
7. Call the `[[Get]]` method of this object with argument `Result(6)`.
8. Call the `[[Delete]]` method of this object with argument `Result(6)`.
9. Call the `[[Put]]` method of this object with arguments `"length"` and `(Result(2)-1)`.
10. Return `Result(7)`.

*NOTE*

The `pop` function is intentionally generic; it does not require that its *this* value be an Array object. Therefore it can be transferred to other kinds of objects for use as a method. Whether the `pop` function can be applied successfully to a host object is implementation-dependent.

#### 15.4.4.7 Array.prototype.push ( [ item1 [ , item2 [ , ... ] ] ] )

The arguments are appended to the end of the array, in the order in which they appear. The new length of the array is returned as the result of the call.

When the `push` method is called with zero or more arguments *item1*, *item2*, etc., the following steps are taken:

1. Call the `[[Get]]` method of this object with argument `"length"`.
2. Let *n* be the result of calling `ToUint32(Result(1))`.
3. Get the next argument in the argument list; if there are no more arguments, go to step 7.
4. Call the `[[Put]]` method of this object with arguments `ToString(n)` and `Result(3)`.
5. Increase *n* by `1`.
6. Go to step 3.
7. Call the `[[Put]]` method of this object with arguments `"length"` and *n*.
8. Return *n*.

The **length** property of the `push` method is `1`.

*NOTE*

The **push** function is intentionally generic; it does not require that its **this** value be an Array object. Therefore it can be transferred to other kinds of objects for use as a method. Whether the **push** function can be applied successfully to a host object is implementation-dependent.

#### 15.4.4.8 Array.prototype.reverse ( )

The elements of the array are rearranged so as to reverse their order. The object is returned as the result of the call.

1. Call the `[[Get]]` method of this object with argument **"length"**.
2. Call `ToUint32(Result(1))`.
3. Compute `floor(Result(2)/2)`.
4. Let *k* be 0.
5. If *k* equals `Result(3)`, return this object.
6. Compute `Result(2)-k-1`.
7. Call `ToString(k)`.
8. Call `ToString(Result(6))`.
9. Call the `[[Get]]` method of this object with argument `Result(7)`.
10. Call the `[[Get]]` method of this object with argument `Result(8)`.
11. If this object does not have a property named by `Result(8)`, go to step 19.
12. If this object does not have a property named by `Result(7)`, go to step 16.
13. Call the `[[Put]]` method of this object with arguments `Result(7)` and `Result(10)`.
14. Call the `[[Put]]` method of this object with arguments `Result(8)` and `Result(9)`.
15. Go to step 25.
16. Call the `[[Put]]` method of this object with arguments `Result(7)` and `Result(10)`.
17. Call the `[[Delete]]` method on this object, providing `Result(8)` as the name of the property to delete.
18. Go to step 25.
19. If this object does not have a property named by `Result(7)`, go to step 23.
20. Call the `[[Delete]]` method on this object, providing `Result(7)` as the name of the property to delete.
21. Call the `[[Put]]` method of this object with arguments `Result(8)` and `Result(9)`.
22. Go to step 25.
23. Call the `[[Delete]]` method on this object, providing `Result(7)` as the name of the property to delete.
24. Call the `[[Delete]]` method on this object, providing `Result(8)` as the name of the property to delete.
25. Increase *k* by 1.
26. Go to step 5.

#### NOTE

The **reverse** function is intentionally generic; it does not require that its **this** value be an Array object. Therefore, it can be transferred to other kinds of objects for use as a method. Whether the **reverse** function can be applied successfully to a host object is implementation-dependent.

#### 15.4.4.9 Array.prototype.shift ( )

The first element of the array is removed from the array and returned.

1. Call the `[[Get]]` method of this object with argument **"length"**.
2. Call `ToUint32(Result(1))`.
3. If `Result(2)` is not zero, go to step 6.
4. Call the `[[Put]]` method of this object with arguments **"length"** and `Result(2)`.
5. Return **undefined**.
6. Call the `[[Get]]` method of this object with argument 0.
7. Let *k* be 1.
8. If *k* equals `Result(2)`, go to step 18.
9. Call `ToString(k)`.
10. Call `ToString(k-1)`.
11. If this object has a property named by `Result(9)`, go to step 12; but if this object has no property named by `Result(9)`, then go to step 15.

12. Call the `[[Get]]` method of this object with argument `Result(9)`.
13. Call the `[[Put]]` method of this object with arguments `Result(10)` and `Result(12)`.
14. Go to step 16.
15. Call the `[[Delete]]` method of this object with argument `Result(10)`.
16. Increase *k* by 1.
17. Go to step 8.
18. Call the `[[Delete]]` method of this object with argument `ToString(Result(2)-1)`.
19. Call the `[[Put]]` method of this object with arguments `"length"` and `(Result(2)-1)`.
20. Return `Result(6)`.

**NOTE**

The `shift` function is intentionally generic; it does not require that its `this` value be an Array object. Therefore it can be transferred to other kinds of objects for use as a method. Whether the `shift` function can be applied successfully to a host object is implementation-dependent.

**15.4.4.10 Array.prototype.slice (start, end)**

The `slice` method takes two arguments, *start* and *end*, and returns an array containing the elements of the array from element *start* up to, but not including, element *end* (or through the end of the array if *end* is `undefined`). If *start* is negative, it is treated as  $(length+start)$  where *length* is the length of the array. If *end* is negative, it is treated as  $(length+end)$  where *length* is the length of the array. The following steps are taken:

1. Let *A* be a new array created as if by the expression `new Array()` [where Array is the standard built-in constructor with that name](#).
2. Call the `[[Get]]` method of this object with argument `"length"`.
3. Call `ToUint32(Result(2))`.
4. Call `ToInteger(start)`.
5. If `Result(4)` is negative, use  $\max((\text{Result}(3)+\text{Result}(4)),0)$ ; else use  $\min(\text{Result}(4),\text{Result}(3))$ .
6. Let *k* be `Result(5)`.
7. If *end* is `undefined`, use `Result(3)`; else use `ToInteger(end)`.
8. If `Result(7)` is negative, use  $\max((\text{Result}(3)+\text{Result}(7)),0)$ ; else use  $\min(\text{Result}(7),\text{Result}(3))$ .
9. Let *n* be 0.
10. If *k* is greater than or equal to `Result(8)`, go to step 19.
11. Call `ToString(k)`.
12. If this object has a property named by `Result(11)`, go to step 13; but if this object has no property named by `Result(11)`, then go to step 16.
13. Call `ToString(n)`.
14. Call the `[[Get]]` method of this object with argument `Result(11)`.
15. Call the `[[Put]]` method of *A* with arguments `Result(13)` and `Result(14)`.
16. Increase *k* by 1.
17. Increase *n* by 1.
18. Go to step 10.
19. Call the `[[Put]]` method of *A* with arguments `"length"` and *n*.
20. Return *A*.

The `length` property of the `slice` method is 2.

**NOTE**

The `slice` function is intentionally generic; it does not require that its `this` value be an Array object. Therefore it can be transferred to other kinds of objects for use as a method. Whether the `slice` function can be applied successfully to a host object is implementation-dependent.

**15.4.4.11 Array.prototype.sort (comparefn)**

The elements of this array are sorted. The sort is not necessarily stable (that is, elements that compare equal do not necessarily remain in their original order). If *comparefn* is not `undefined`, it should be a function that accepts two arguments *x* and *y* and returns a negative value if  $x < y$ , zero if  $x = y$ , or a positive value if  $x > y$ .

If *comparefn* is not `undefined` and is not a consistent comparison function for the elements of this array (see below), the behaviour of `sort` is implementation-defined. Let *len* be



ToUint32(**this.length**). If there exist integers  $i$  and  $j$  and an object  $P$  such that all of the conditions below are satisfied then the behaviour of **sort** is implementation-defined:

$0 \leq i < len$

$0 \leq j < len$

**this** does not have a property with name ToString( $i$ )

$P$  is obtained by following one or more [[Prototype]] properties starting at **this**

$P$  has a property with name ToString( $j$ )

Otherwise the following steps are taken.

1. Call the [[Get]] method of this object with argument "**length**".
2. Call ToUint32(Result(1)).
3. Perform an implementation-dependent sequence of calls to the [[Get]], [[Put]], and [[Delete]] methods of this object and to SortCompare (described below), where the first argument for each call to [[Get]], [[Put]], or [[Delete]] is a nonnegative integer less than Result(2) and where the arguments for calls to SortCompare are results of previous calls to the [[Get]] method.
4. Return this object.

The returned object must have the following two properties.

There must be some mathematical permutation  $\pi$  of the nonnegative integers less than Result(2), such that for every nonnegative integer  $j$  less than Result(2), if property **old**[ $j$ ] existed, then **new**[ $\pi(j)$ ] is exactly the same value as **old**[ $j$ ]. But if property **old**[ $j$ ] did not exist, then **new**[ $\pi(j)$ ] does not exist.

Then for all nonnegative integers  $j$  and  $k$ , each less than Result(2), if  $\text{SortCompare}(j,k) < 0$  (see SortCompare below), then  $\pi(j) < \pi(k)$ .

Here the notation **old**[ $j$ ] is used to refer to the hypothetical result of calling the [[Get]] method of this object with argument  $j$  before this function is executed, and the notation **new**[ $j$ ] to refer to the hypothetical result of calling the [[Get]] method of this object with argument  $j$  after this function has been executed.

A function *comparefn* is a consistent comparison function for a set of values  $S$  if all of the requirements below are met for all values  $a$ ,  $b$ , and  $c$  (possibly the same value) in the set  $S$ : The notation  $a <_{CF} b$  means *comparefn*( $a,b$ ) < 0;  $a =_{CF} b$  means *comparefn*( $a,b$ ) = 0 (of either sign); and  $a >_{CF} b$  means *comparefn*( $a,b$ ) > 0.

Calling *comparefn*( $a,b$ ) always returns the same value  $v$  when given a specific pair of values  $a$  and  $b$  as its two arguments. Furthermore,  $v$  has type Number, and  $v$  is not NaN. Note that this implies that exactly one of  $a <_{CF} b$ ,  $a =_{CF} b$ , and  $a >_{CF} b$  will be true for a given pair of  $a$  and  $b$ .

$a =_{CF} a$  (reflexivity)

If  $a =_{CF} b$ , then  $b =_{CF} a$  (symmetry)

If  $a =_{CF} b$  and  $b =_{CF} c$ , then  $a =_{CF} c$  (transitivity of =<sub>CF</sub>)

If  $a <_{CF} b$  and  $b <_{CF} c$ , then  $a <_{CF} c$  (transitivity of <<sub>CF</sub>)

If  $a >_{CF} b$  and  $b >_{CF} c$ , then  $a >_{CF} c$  (transitivity of ><sub>CF</sub>)

#### NOTE

The above conditions are necessary and sufficient to ensure that *comparefn* divides the set  $S$  into equivalence classes and that these equivalence classes are totally ordered.

When the SortCompare operator is called with two arguments  $j$  and  $k$ , the following steps are taken:

1. Call ToString( $j$ ).
2. Call ToString( $k$ ).
3. If this object does not have a property named by Result(1), and this object does not have a property named by Result(2), return +0.
4. If this object does not have a property named by Result(1), return 1.
5. If this object does not have a property named by Result(2), return -1.

6. Call the `[[Get]]` method of this object with argument `Result(1)`.
7. Call the `[[Get]]` method of this object with argument `Result(2)`.
8. Let  $x$  be `Result(6)`.
9. Let  $y$  be `Result(7)`.
10. If  $x$  and  $y$  are both **undefined**, return **+0**.
11. If  $x$  is **undefined**, return `1`.
12. If  $y$  is **undefined**, return `-1`.
13. If the argument `comparefn` is **undefined**, go to step 16.
14. Call `comparefn` with arguments  $x$  and  $y$ .
15. Return `Result(14)`.
16. Call `ToString(x)`.
17. Call `ToString(y)`.
18. If `Result(16) < Result(17)`, return `-1`.
19. If `Result(16) > Result(17)`, return `1`.
20. Return **+0**.

*NOTE 1*

*Because non-existent property values always compare greater than **undefined** property values, and **undefined** always compares greater than any other value, undefined property values always sort to the end of the result, followed by non-existent property values.*

*NOTE 2*

*The `sort` function is intentionally generic; it does not require that its `this` value be an Array object. Therefore, it can be transferred to other kinds of objects for use as a method. Whether the `sort` function can be applied successfully to a host object is implementation-dependent.*

**15.4.4.12 Array.prototype.splice (start, deleteCount [, item1 [, item2 [, ... ] ] ] )**

When the `splice` method is called with two or more arguments `start`, `deleteCount` and (optionally) `item1`, `item2`, etc., the `deleteCount` elements of the array starting at array index `start` are replaced by the arguments `item1`, `item2`, etc. The following steps are taken:

1. Let  $A$  be a new array created as if by the expression `new Array()` [where Array is the standard built-in constructor with that name](#).
2. Call the `[[Get]]` method of this object with argument `"length"`.
3. Call `ToUint32(Result(2))`.
4. Call `ToInteger(start)`.
5. If `Result(4)` is negative, use `max((Result(3)+Result(4)),0)`; else use `min(Result(4),Result(3))`.
6. Compute `min(max(ToInteger(deleteCount),0),Result(3)-Result(5))`.
7. Let  $k$  be `0`.
8. If  $k$  equals `Result(6)`, go to step 16.
9. Call `ToString(Result(5)+k)`.
10. If this object has a property named by `Result(9)`, go to step 11; but if this object has no property named by `Result(9)`, then go to step 14.
11. Call `ToString(k)`.
12. Call the `[[Get]]` method of this object with argument `Result(9)`.
13. Call the `[[Put]]` method of  $A$  with arguments `Result(11)` and `Result(12)`.
14. Increment  $k$  by `1`.
15. Go to step 8.
16. Call the `[[Put]]` method of  $A$  with arguments `"length"` and `Result(6)`.
17. Compute the number of additional arguments `item1`, `item2`, etc.
18. If `Result(17)` is equal to `Result(6)`, go to step 48.
19. If `Result(17)` is greater than `Result(6)`, go to step 37.
20. Let  $k$  be `Result(5)`.
21. If  $k$  is equal to `(Result(3)-Result(6))`, go to step 31.
22. Call `ToString(k+Result(6))`.
23. Call `ToString(k+Result(17))`.
24. If this object has a property named by `Result(22)`, go to step 25; but if this object has no property named by `Result(22)`, then go to step 28.
25. Call the `[[Get]]` method of this object with argument `Result(22)`.

26. Call the `[[Put]]` method of this object with arguments `Result(23)` and `Result(25)`.
27. Go to step 29.
28. Call the `[[Delete]]` method of this object with argument `Result(23)`.
29. Increase  $k$  by 1.
30. Go to step 21.
31. Let  $k$  be `Result(3)`.
32. If  $k$  is equal to  $(\text{Result}(3) - \text{Result}(6) + \text{Result}(17))$ , go to step 48.
33. Call `ToString(k-1)`.
34. Call the `[[Delete]]` method of this object with argument `Result(33)`.
35. Decrease  $k$  by 1.
36. Go to step 32.
37. Let  $k$  be  $(\text{Result}(3) - \text{Result}(6))$ .
38. If  $k$  is equal to `Result(5)`, go to step 48.
39. Call `ToString(k+Result(6)-1)`.
40. Call `ToString(k+Result(17)-1)`.
41. If this object has a property named by `Result(39)`, go to step 42; but if this object has no property named by `Result(39)`, then go to step 45.
42. Call the `[[Get]]` method of this object with argument `Result(39)`.
43. Call the `[[Put]]` method of this object with arguments `Result(40)` and `Result(42)`.
44. Go to step 46.
45. Call the `[[Delete]]` method of this object with argument `Result(40)`.
46. Decrease  $k$  by 1.
47. Go to step 38.
48. Let  $k$  be `Result(5)`.
49. Get the next argument in the part of the argument list that starts with *item1*; if there are no more arguments, go to step 53.
50. Call the `[[Put]]` method of this object with arguments `ToString(k)` and `Result(49)`.
51. Increase  $k$  by 1.
52. Go to step 49.
53. Call the `[[Put]]` method of this object with arguments `"length"` and  $(\text{Result}(3) - \text{Result}(6) + \text{Result}(17))$ .
54. Return *A*.

The `length` property of the `splice` method is 2.

**NOTE**

The `splice` function is intentionally generic; it does not require that its *this* value be an Array object. Therefore it can be transferred to other kinds of objects for use as a method. Whether the `splice` function can be applied successfully to a host object is implementation-dependent.

**15.4.4.13 Array.prototype.unshift ( [ item1 [ , item2 [ , ... ] ] ] )**

The arguments are prepended to the start of the array, such that their order within the array is the same as the order in which they appear in the argument list.

When the `unshift` method is called with zero or more arguments *item1*, *item2*, etc., the following steps are taken:

1. Call the `[[Get]]` method of this object with argument `"length"`.
2. Call `ToUint32(Result(1))`.
3. Compute the number of arguments.
4. Let  $k$  be `Result(2)`.
5. If  $k$  is zero, go to step 15.
6. Call `ToString(k-1)`.
7. Call `ToString(k+Result(3)-1)`.
8. If this object has a property named by `Result(6)`, go to step 9; but if this object has no property named by `Result(6)`, then go to step 12.
9. Call the `[[Get]]` method of this object with argument `Result(6)`.
10. Call the `[[Put]]` method of this object with arguments `Result(7)` and `Result(9)`.
11. Go to step 13.
12. Call the `[[Delete]]` method of this object with argument `Result(7)`.

13. Decrease *k* by 1.
14. Go to step 5.
15. Let *k* be 0.
16. Get the next argument in the part of the argument list that starts with *item1*; if there are no more arguments, go to step 21.
17. Call ToString(*k*).
18. Call the [[Put]] method of this object with arguments Result(17) and Result(16).
19. Increase *k* by 1.
20. Go to step 16.
21. Call the [[Put]] method of this object with arguments "length" and (Result(2)+Result(3)).
22. Return (Result(2)+Result(3)).

The **length** property of the **unshift** method is 1.

*NOTE*

The **unshift** function is intentionally generic; it does not require that its **this** value be an Array object. Therefore it can be transferred to other kinds of objects for use as a method. Whether the **unshift** function can be applied successfully to a host object is implementation-dependent.

#### 15.4.4.14 Array.prototype.indexOf ( searchElement [, fromIndex ] )

indexOf compares *searchElement* to the elements of the array, in ascending order, using strict equality, and if found at one or more positions, returns the index of the first such position; otherwise, -1 is returned.

The optional second argument *fromIndex* defaults to 0 (i.e. the whole array is searched). If it is greater than or equal to the length of the array, -1 is returned, i.e. the array will not be searched. If it is negative, it is used as the offset from the end of the array to compute *fromIndex*. If the computed index is less than 0, the whole array will be searched.

When the **indexOf** method is called with one or two arguments, the following steps are taken:

1. Let *E* be this object.
2. Call the [[Get]] method of *E* with the argument "length".
3. Call ToUint32(Result(2)).
4. If Result(3) is 0 go to step 18.
5. Call ToInt32(*fromIndex*) (if *fromIndex* is **undefined** this step produces 0).
6. Let *n* be Result(5).
7. If *n* is greater than or equal to Result(3) go to step 18.
8. If *n* is greater than or equal to 0, let *k* be *n*, and go to step 11.
9. Let *k* be Result(3) - abs(*n*).
10. If *k* is less than 0, let *k* be 0.
11. Call ToString(*k*).
12. Call the [[Get]] method of *E* with the argument Result(11).
13. Perform the comparison *searchElement* === Result(12).
14. If Result(13) is **false** go to step 16.
15. Return *k*.
16. Increase *k* by 1.
17. If *k* is less than Result(3) go to step 11.
18. Return -1.

The **length** property of the **indexOf** method is 1.

*NOTE*

The **indexOf** function is intentionally generic; it does not require that its **this** value be an Array object. Therefore it can be transferred to other kinds of objects for use as a method. Whether the **indexOf** function can be applied successfully to a host object is implementation-dependent.

#### 15.4.4.15 Array.prototype.lastIndexOf ( searchElement [, fromIndex ] )

**lastIndexOf** compares *searchElement* to the elements of the array in descending order using strict equality, and if found at one or more positions, returns the index of the last such position; otherwise, -1 is returned.

The optional second argument *fromIndex* defaults to the array's length (i.e. the whole array is searched). If it is greater than or equal to the length of the array, the whole array will be searched. If it is negative, it is used as the offset from the end of the array to compute *fromIndex*. If the computed index is less than 0, -1 is returned.

When the **lastIndexOf** method is called with one or two arguments, the following steps are taken:

1. Let *E* be this object.
2. Call the [[Get]] method of *E* with the argument "**length**".
3. Call ToUint32(Result(2)).
4. If Result(3) is 0 go to step 18.
5. Call ToInt32(fromIndex) (if *fromIndex* is undefined this step produces the same values as Result(3)).
6. Let *n* be Result(5).
7. If *n* is greater than or equal to Result(3), let *k* be Result(3) - 1, and go to step 11.
8. If *n* is greater than or equal to 0, let *k* be *n*, and go to step 11.
9. Let *k* be Result(3) - abs(*n*).
10. If *k* is less than 0 go to step 18.
11. Call ToString(*k*).
12. Call the [[Get]] method of *E* with the argument Result(11).
13. Perform the comparison searchElement === Result(12).
14. If Result(13) is false go to step 16.
15. Return *k*.
16. Decrease *k* by 1.
17. If *k* is greater than or equal to 0 go to step 11.
18. Return -1.

The **length** property of the **lastIndexOf** method is 1.

#### NOTE

*The **lastIndexOf** function is intentionally generic; it does not require that its **this** value be an Array object. Therefore it can be transferred to other kinds of objects for use as a method. Whether the **lastIndexOf** function can be applied successfully to a host object is implementation-dependent.*

#### 15.4.4.16 Array.prototype.every ( callbackfn [, thisArg ] )

*callbackfn* should be a function that accepts three arguments and returns the boolean value **true** or **false**. **every** calls the provided *callback*, as a function, once for each element present in the array, in ascending order, until it finds one where *callbackfn* returns **false**. If such an element is found, **every** immediately returns **false**. Otherwise, if *callbackfn* returned **true** for all elements, **every** will return **true**. *callbackfn* is called only for indexes of the array which have assigned values; it is not called for indexes which have been deleted or which have never been assigned values.

If a *thisArg* parameter is provided, it will be used as the **this** for each invocation of the callback. If it is not provided, or is **null**, the global object associated with the callback is used instead.

*callbackfn* is called with three arguments: the value of the element, the index of the element, and the Array object being traversed.

**every** does not mutate the array on which it is called.

The range of elements processed by **every** is set before the first call to *callbackfn*. Elements which are appended to the array after the call to **every** begins will not be visited by *callbackfn*. If existing elements of the array are changed, their value as passed to *callbackfn* will be the value at the time **every** visits them; elements that are deleted are not visited. **every** acts like the "for all" quantifier in mathematics. In particular, for an empty array, it returns **true**.

When the **every** method is called with one or two arguments, the following steps are taken:

1. Let *E* be this object.
2. Call the `[[Get]]` method of *E* with the argument "`length`".
3. Call `ToUint32(Result(2))`.
4. If `Result(3)` is 0 go to step 18.
5. If `Type(callbackfn)` is not `Object`, throw a `TypeError` exception.
6. If `IsCallable(callbackfn)` is `false`, throw a `TypeError` exception.
7. Let *O* be *thisArg*.
8. Let *k* be 0.
9. Call `ToString(k)`.
10. If *E* does not have a property named by `Result(9)`, go to step 16.
11. Call the `[[Get]]` method of *E* with argument `Result(9)`.
12. Call the `[[Call]]` method of *callbackfn* with *O* as the `this` value and arguments `Result(11)`, *k*, and *E*.
13. Call `ToBoolean(Result(12))`.
14. If `Result(13)` is `true` go to step 16.
15. Return `false`.
16. Increase *k* by 1.
17. If *k* is less than `Result(3)` go to step 9.
18. Return `true`.

The `length` property of the `every` method is 1.

**NOTE**

*The `every` function is intentionally generic; it does not require that its `this` value be an Array object. Therefore it can be transferred to other kinds of objects for use as a method. Whether the `every` function can be applied successfully to a host object is implementation-dependent.*

**15.4.4.17 Array.prototype.some ( callbackfn [, thisArg ] )**

*callbackfn* should be a function that accepts three arguments and returns the boolean value `true` or `false`. `some` calls the callback, as a function, once for each element present in the array, in ascending order, until it finds one where *callbackfn* returns `true`. If such an element is found, `some` immediately returns `true`. Otherwise, `some` returns `false`. *callbackfn* is called only for indexes of the array which have assigned values; it is not called for indexes which have been deleted or which have never been assigned values.

If a *thisArg* parameter is provided, it will be used as the `this` for each invocation of the callback. If it is not provided, or is `null`, the global object associated with the callback is used instead.

*callbackfn* is called with three arguments: the value of the element, the index of the element, and the Array object being traversed.

`some` does not mutate the array on which it is called.

The range of elements processed by `some` is set before the first call to *callbackfn*. Elements that are appended to the array after the call to `some` begins will not be visited by *callbackfn*. If an existing, unvisited element of the array is changed by *callbackfn*, their value as passed to *callbackfn* will be the value at the time that `some` visits them; elements that are deleted are not visited.

When the `some` method is called with one or two arguments, the following steps are taken:

1. Let *E* be this object.
2. Call the `[[Get]]` method of *E* with the argument "`length`".
3. Call `ToUint32(Result(2))`.
4. If `Result(3)` is 0 go to step 18.
5. If `Type(callbackfn)` is not `Object`, throw a `TypeError` exception.
6. If `IsCallable(callbackfn)` is `false`, throw a `TypeError` exception.
7. Let *O* be *thisArg*.
8. Let *k* be 0.
9. Call `ToString(k)`.
10. If *E* does not have a property named by `Result(9)`, go to step 16.
11. Call the `[[Get]]` method of *E* with argument `Result(9)`.
12. Call the `[[Call]]` method of *callbackfn* with *O* as the `this` value and arguments `Result(11)`, *k*, and *E*.

13. Call `ToBoolean(Result(12))`.
14. If `Result(13)` is `false` go to step 16.
15. Return `true`.
16. Increase `k` by 1.
17. If `k` is less than `Result(3)` go to step 9.
18. Return `false`.

The `length` property of the `some` method is 1.

*NOTE*

*The `some` function is intentionally generic; it does not require that its `this` value be an Array object. Therefore it can be transferred to other kinds of objects for use as a method. Whether the `some` function can be applied successfully to a host object is implementation-dependent.*

#### 15.4.4.18 `Array.prototype.forEach ( callbackfn [ , thisArg ] )`

`callbackfn` should be a function that accepts three arguments. `forEach` calls the provided callback, as a function, once for each element present in the array, in ascending order. `callbackfn` is called only for indexes of the array which have assigned values; it is not called for indexes which have been deleted or which have never been assigned values.

If a `thisArg` parameter is provided, it will be used as the `this` for each invocation of the callback. If it is not provided, or is `null`, the global object associated with the callback is used instead.

`callbackfn` is called with three arguments: the value of the element, the index of the element, and the Array object being traversed.

`forEach` does not mutate the array on which it is called.

The range of elements processed by `forEach` is set before the first call to `callbackfn`. Elements which are appended to the array after the call to `forEach` begins will not be visited by `callbackfn`. If existing elements of the array are changed, or deleted, their value as passed to callback will be the value at the time `forEach` visits them; elements that are deleted are not visited.

When the `forEach` method is called with one or two arguments, the following steps are taken:

1. Let `E` be this object.
2. Call the `[[Get]]` method of `E` with the argument `"length"`.
3. Call `ToUint32(Result(2))`.
4. If `Result(3)` is 0 go to step 14.
5. If `Type(callbackfn)` is not `Object`, throw a `TypeError` exception.
6. If `IsCallable(callbackfn)` is `false`, throw a `TypeError` exception.
7. Let `O` be `thisArg`.
8. Let `k` be 0.
9. Call `ToString(k)`.
10. If `E` does not have a property named by `Result(9)`, go to step 13.
11. Call the `[[Get]]` method of `E` with argument `Result(9)`.
12. Call the `[[Call]]` method of `callbackfn` with `O` as `this` value and arguments `Result(11)`, `k`, and `E`.
13. Increase `k` by 1.
14. If `k` is less than `Result(3)` go to step 9.
15. Return.

The `length` property of the `forEach` method is 1.

*NOTE*

*The `forEach` function is intentionally generic; it does not require that its `this` value be an Array object. Therefore it can be transferred to other kinds of objects for use as a method. Whether the `forEach` function can be applied successfully to a host object is implementation-dependent.*

#### 15.4.4.19 `Array.prototype.map ( callbackfn [ , thisArg ] )`

`callbackfn` should be a function that accepts three arguments. `map` calls the provided callback, as a function, once for each element in the array, in ascending order, and constructs a new array from the

results. *callbackfn* is called only for indexes of the array which have assigned values; it is not called for indexes which have been deleted or which have never been assigned values.

If a *thisArg* parameter is provided, it will be used as the **this** for each invocation of the callback. If it is not provided, or is **null**, the global object associated with the callback is used instead.

*callbackfn* is called with three arguments: the value of the element, the index of the element, and the Array object being traversed.

**map** does not mutate the array on which it is called.

The range of elements processed by **map** is set before the first call to *callbackfn*. Elements which are appended to the array after the call to **map** begins will not be visited by *callbackfn*. If existing elements of the array are changed, or deleted, their value as passed to *callbackfn* will be the value at the time **map** visits them; elements that are deleted are not visited.

When the **map** method is called with one or two arguments, the following steps are taken:

1. Let *A* be a new array created as if by the expression **new Array()** where **Array** is the standard built-in constructor with that name.
2. Let *n* be 0.
3. Let *E* be this object
4. Call the **[[Get]]** method of *E* with the argument "**length**".
5. Call **ToUint32**(**Result**(4)).
6. If **Result**(5) is 0 go to step 20.
7. If **Type**(*callbackfn*) is not **Object**, throw a **TypeError** exception.
8. If **IsCallable**(*callbackfn*) is **false**, throw a **TypeError** exception.
9. Let *O* be *thisArg*.
10. Let *k* be 0.
11. Call **ToString**(*k*).
12. If *E* does not have a property named by **Result**(11), go to step 19.
13. Call the **[[Get]]** method of *E* with argument **Result**(11).
14. Call the **[[Call]]** method of *callbackfn* with *O* as the **this** value and arguments **Result**(13), *k*, and *E*.
15. Call **ToString**(*n*).
16. Call the **[[Put]]** method of *A* with the argument **Result**(14) and **Result**(15).
17. Increase *n* by 1.
18. Increase *k* by 1.
19. If *k* is less than **Result**(5) go to step 11.
20. Return *A*.

The **length** property of the **map** method is **1**.

#### NOTE

The **map** function is intentionally generic; it does not require that its **this** value be an Array object. Therefore it can be transferred to other kinds of objects for use as a method. Whether the **map** function can be applied successfully to a host object is implementation-dependent.

#### **15.4.4.20** **Array.prototype.filter** ( *callbackfn* [, *thisArg* ] )

*callbackfn* should be a function that accepts three arguments and returns the boolean value **true** or **false**. **filter** calls the provided callback, as a function, once for each element in the array, in ascending order, and constructs a new array of all the values for which *callbackfn* returns **true**. *callbackfn* is called only for indexes of the array which have assigned values; it is not called for indexes which have been deleted or which have never been assigned values.

If a *thisArg* parameter is provided, it will be used as the **this** for each invocation of the callback. If it is not provided, or is **null**, the global object associated with the callback is used instead.

*callbackfn* is called with three arguments: the value of the element, the index of the element, and the Array object being traversed.

**filter** does not mutate the array on which it is called.



The range of elements processed by **filter** is set before the first call to *callbackfn*. Elements which are appended to the array after the call to **filter** begins will not be visited by *callbackfn*. If existing elements of the array are changed, or deleted, their value as passed to *callbackfn* will be the value at the time **filter** visits them; elements that are deleted are not visited.

When the **filter** method is called with one or two arguments, the following steps are taken:

1. Let *A* be a new array created as if by the expression `new Array()` where **Array** is the standard built-in constructor with that name.
2. Let *n* be 0.
3. Let *E* be this object
4. Call the `[[Get]]` method of *E* with the argument "**length**".
5. Call `ToUint32(Result(4))`.
6. If `Result(5)` is 0 go to step 22.
7. If `Type(callbackfn)` is not Object, throw a **TypeError** exception.
8. If `IsCallable(callbackfn)` is **false**, throw a **TypeError** exception.
9. Let *O* be *thisArg*.
10. Let *k* be 0.
11. Call `ToString(k)`.
12. If *E* does not have a property named by `Result(11)`, go to step 20.
13. Call the `[[Get]]` method of *E* with argument `Result(11)`.
14. Call the `[[Call]]` method of *callbackfn* with *O* as the **this** value and arguments `Result(13)`, *k*, and *E*.
15. Call `ToBoolean(Result(14))`.
16. If `Result(15)` is **false** go to step 20.
17. Call `ToString(n)`.
18. Call the `[[Put]]` method of *A* with the argument `Result(13)` and `Result(17)`.
19. Increase *n* by 1.
20. Increase *k* by 1.
21. If *k* is less than `Result(5)` go to step 11.
22. Return *A*.

The **length** property of the **filter** method is 1.

#### NOTE

*The filter function is intentionally generic; it does not require that its this value be an Array object. Therefore it can be transferred to other kinds of objects for use as a method. Whether the filter function can be applied successfully to a host object is implementation-dependent.*

#### 15.4.4.21 Array.prototype.reduce ( callbackfn [ , initialValue ] )

*callbackfn* should be a function that takes four arguments. **reduce** calls the callback, as a function, once for each element present in the array, in ascending order.

*callbackfn* is called with four arguments: the previousValue (or value from the previous call to *callbackfn*), the currentValue (value of the current element), the currentIndex, and the Array object being traversed. The first time that callback is called, the previousValue and currentValue can be one of two values. If an *initialValue* was provided in the call to **reduce**, then previousValue will be equal to *initialValue* and currentValue will be equal to the first value in the array. If no *initialValue* was provided, then previousValue will be equal to the first value in the array and currentValue will be equal to the second.

**reduce** does not mutate the array on which it is called.

The range of elements processed by **reduce** is set before the first call to *callbackfn*. Elements that are appended to the array after the call to **reduce** begins will not be visited by *callbackfn*. If an existing, unvisited element is changed by *callbackfn*, their value as passed to *callbackfn* will be the value at the time **reduce** visits them; elements that are deleted are not visited.

When the **reduce** method is called with one or two arguments, the following steps are taken:

1. Let *E* be this object.
2. Call the `[[Get]]` method on *E* with argument "**length**".

3. Call `ToUint32(Result(2))`.
4. If `Type(callbackfn)` is not `Object`, throw a **`TypeError`** exception.
5. If `IsCallable(callbackfn)` is **false**, throw a **`TypeError`** exception.
6. If `Result(3)` is 0 and `initialValue` is not supplied throw a **`TypeError`** exception.
7. Let `k` be 0.
8. If `initialValue` is supplied let `P` be `initialValue` and go to step 17.
9. Call `ToString(k)`.
10. If `E` does not have a property named by `Result(9)`, go to step 14.
11. Call the `[[Get]]` method on `E` with the argument `Result(9)`.
12. Increase `k` by 1.
13. Let `P` be `Result(11)` and go to step 17.
14. Increase `k` by 1.
15. If `k < Result(3)` go to step 9.
16. Throw a **`TypeError`** exception.
17. Call `ToString(k)`.
18. If `E` does not have a property named by `Result(17)`, go to step 22.
19. Call the `[[Get]]` method of `E` with the argument `Result(17)`.
20. Call the `[[Call]]` method on `callbackfn` with **null** as the `this` value and arguments `P`, `Result(19)`, `k`, `E`.
21. Let `P` be `Result(20)`.
22. Increase `k` by 1.
23. If `k < Result(3)` go to step 17.
24. Return `P`.

The `length` property of the `reduce` method is 1.

**NOTE**

The `reduce` function is intentionally generic; it does not require that its `this` value be an `Array` object. Therefore it can be transferred to other kinds of objects for use as a method. Whether the `reduce` function can be applied successfully to a host object is implementation-dependent.

**15.4.4.22 `Array.prototype.reduceRight ( callbackfn [, initialValue ] )`**

`callbackfn` should be a function that takes four arguments. `reduceRight` calls the callback, as a function, once for each element present in the array, in descending order.

`callbackfn` is called with four arguments: the `previousValue` (or value from the previous call to `callbackfn`), the `currentValue` (value of the current element), the `currentIndex`, and the `Array` object being traversed. The first time the function is called, the `previousValue` and `currentValue` can be one of two values. If an `initialValue` was provided in the call to `reduceRight`, then `previousValue` will be equal to `initialValue` and `currentValue` will be equal to the last value in the array. If no `initialValue` was provided, then `previousValue` will be equal to the last value in the array and `currentValue` will be equal to the second-to-last value.

`reduceRight` does not mutate the array on which it is called.

The range of elements processed by `reduceRight` is set before the first call to `callbackfn`. Elements that are appended to the array after the call to `reduceRight` begins will not be visited by `callbackfn`. If an existing, unvisited element is changed by `callbackfn`, their value as passed to `callbackfn` will be the value at the time `reduceRight` visits them; elements that are deleted are not visited.

When the `reduceRight` method is called with one or two arguments, the following steps are taken:

1. Let `E` be this object.
2. Call the `[[Get]]` method on `E` with argument `"length"`.
3. Call `ToUint32(Result(2))`.
4. If `Type(callbackfn)` is not `Object` throw a **`TypeError`** exception.
5. If `IsCallable(callbackfn)` is **false**, throw a **`TypeError`** exception.
6. If `Result(3)` is 0 and `initialValue` is not supplied throw a **`TypeError`** exception.
7. Let `k` be `Result(3) - 1`.
8. If `initialValue` is supplied let `P` be `initialValue` and go to step 17.
9. Call `ToString(k)`.

- 10. If *E* does not have a property named by Result(9), go to step 14.
- 11. Call the `[[Get]]` method on *E* with the argument Result(9).
- 12. Decrease *k* by 1.
- 13. Let *P* be Result(11) and go to step 17.
- 14. Decrease *k* by 1.
- 15. If *k* is greater than or equal to 0 go to step 9.
- 16. Throw a **TypeError** exception.
- 17. Call `ToString(k)`.
- 18. If *E* does not have a property named by Result(17), go to step 22.
- 19. Call the `[[Get]]` method of *E* with the argument Result(17).
- 20. Call the `[[Call]]` method on *callbackfn* with **null** as the **this** value and arguments *P*, Result(19), *k*, *E*.
- 21. Let *P* be Result(20).
- 22. Decrease *k* by 1.
- 23. If *k* is greater than or equal to 0 go to step 17.
- 24. Return *P*.

The `length` property of the `reduceRight` method is 1.

**NOTE**

The `reduceRight` function is intentionally generic; it does not require that its **this** value be an Array object. Therefore it can be transferred to other kinds of objects for use as a method. Whether the `reduceRight` function can be applied successfully to a host object is implementation-dependent.

**15.4.5 Properties of Array Instances**

Array instances inherit properties from the Array prototype object and also have the following properties.

**15.4.5.1 `[[ThrowablePut]]` (*P*, *V*, *Throw*)**

Array objects use a variation of the `[[ThrowablePut]]` method used for other native ECMAScript objects (8.6.2.10).

Assume *A* is an Array object, *P* is a string, and *Throw* is a boolean flag.

When the `[[ThrowablePut]]` method of *A* is called with property *P*, value *V*, and Boolean flag *Throw*, the following steps are taken:

- 1. Call the `[[CanPut]]` method of *A* with name *P*.
- 2. If Result(1) is false, then
  - a. If *Throw* is true, throw a **TypeError** exception.
  - b. Else return.
- 3. If *A* doesn't have a property with name *P*, go to step 7.
- 4. If *P* is "length", go to step 12.
- 5. Set the value of property *P* of *A* to *V*.
- 6. Go to step 8.
- 7. Create a property with name *P*, set its value to *V* and give it empty attributes.
- 8. If *P* is not an array index, return.
- 9. If `ToUint32(P)` is less than the value of the length property of *A*, then return.
- 10. Change (or set) the value of the length property of *A* to `ToUint32(P)+1`.
- 11. Return.
- 12. Compute `ToUint32(V)`.
- 13. If Result(12) is not equal to `ToNumber(V)`, throw a **RangeError** exception.
- 14. For every integer *k* that is less than the value of the length property of *A* but not less than Result(12), if *A* itself has a property (not an inherited property) named `ToString(k)`, then delete that property.
- 15. Set the value of property *P* of *A* to Result(12).
- 16. Return.

**15.4.5.2 `length`**

The `length` property of this Array object is always numerically greater than the name of every property whose name is an array index.

pratapL 7/2/2008 7:02 AM  
Deleted: 2

pratapL 6/30/2008 9:58 PM  
Deleted: and

pratapL 6/30/2008 9:59 PM  
Deleted: and

pratapL 6/30/2008 10:01 PM  
Deleted: return

pratapL 7/4/2008 10:07 AM  
**Comment [52]:** From AWB:  
This probably should be rewritten using the structured notation

The `length` property has the attributes { `[[Enumerable]]: false, [[Flexible]]: false` }.

pratapL 6/30/2008 10:04 PM  
Deleted: DontEnum, DontDelete

## 15.5 String Objects

### 15.5.1 The String Constructor Called as a Function

When `String` is called as a function rather than as a constructor, it performs a type conversion.

#### 15.5.1.1 String ( [ value ] )

Returns a string value (not a String object) computed by `ToString(value)`. If `value` is not supplied, the empty string "" is returned.

### 15.5.2 The String Constructor

When `String` is called as part of a `new` expression, it is a constructor: it initialises the newly created object.

#### 15.5.2.1 new String ( [ value ] )

The `[[Prototype]]` property of the newly constructed object is set to the original String prototype object, the one that is the initial value of `String.prototype` (15.5.3.1).

The `[[Class]]` property of the newly constructed object is set to `"String"`. [The `\[\[Extensible\]\]` property of the newly constructed object is set to `true`.](#)

The `[[PrimitiveValue]]` property of the newly constructed object is set to `ToString(value)`, or to the empty string if `value` is not supplied.

### 15.5.3 Properties of the String Constructor

The value of the internal `[[Prototype]]` property of the String constructor is the Function prototype object (15.3.4).

Besides the internal properties and the `length` property (whose value is 1), the String constructor has the following properties:

#### 15.5.3.1 String.prototype

The initial value of `String.prototype` is the String prototype object (15.5.4).

This property has the attributes { `[[Writable]]: false, [[Enumerable]]: false, [[Flexible]]: false` }.

#### 15.5.3.2 String.fromCharCode ( [ char0 [ , char1 [ , ... ] ] ] )

Returns a string value containing as many characters as the number of arguments. Each argument specifies one character of the resulting string, with the first argument specifying the first character, and so on, from left to right. An argument is converted to a character by applying the operation `ToUint16` (9.7) and regarding the resulting 16-bit integer as the code point value of a character. If no arguments are supplied, the result is the empty string.

The `length` property of the `fromCharCode` function is 1.

#### 15.5.3.3 String.uniqueIdentifier ( seed )

Returns a string value that is different from the value return by any previous or future call to this function within the program and which does not conform to the syntax of either *Identifier* or *NumericLiteral*. The string value must incorporate the content of the string value that is the result of calling `ToString(seed)` but must also contain other characters in order to achieve the required uniqueness characteristics.

The `length` property of the `uniqueIdentifier` function is 1.

pratapL 5/29/2008 12:33 AM  
Deleted: DontEnum, DontDelete, ReadOnly

### 15.5.4 Properties of the String Prototype Object

The String prototype object is itself a String object (its `[[Class]]` is `"String"`) whose value is an empty string.

The value of the internal `[[Prototype]]` property of the String prototype object is the Object prototype object (15.2.3.1).

#### 15.5.4.1 String.prototype.constructor

The initial value of `String.prototype.constructor` is the built-in `String` constructor.

#### 15.5.4.2 **String.prototype.toString ( )**

Returns this string value. (Note that, for a String object, the **toString** method happens to return the same thing as the **valueOf** method.)

The **toString** function is not generic; it throws a **TypeError** exception if its **this** value is not a String object. Therefore, it cannot be transferred to other kinds of objects for use as a method.

#### 15.5.4.3 **String.prototype.valueOf ( )**

Returns this string value.

The **valueOf** function is not generic; it throws a **TypeError** exception if its **this** value is not a String object. Therefore, it cannot be transferred to other kinds of objects for use as a method.

#### 15.5.4.4 **String.prototype.charAt (pos)**

Returns a string containing the character at position *pos* in the string resulting from converting this object to a string. If there is no character at that position, the result is the empty string. The result is a string value, not a String object.

If *pos* is a value of Number type that is an integer, then the result of **x.charAt(pos)** is equal to the result of **x.substring(pos, pos+1)**.

When the **charAt** method is called with one argument *pos*, the following steps are taken:

1. Call **ToString**, giving it the **this** value as its argument.
2. Call **ToInteger(pos)**.
3. Compute the number of characters in **Result(1)**.
4. If **Result(2)** is less than 0 or is not less than **Result(3)**, return the empty string.
5. Return a string of length 1, containing one character from **Result(1)**, namely the character at position **Result(2)**, where the first (leftmost) character in **Result(1)** is considered to be at position 0, the next one at position 1, and so on.

#### NOTE

The **charAt** function is intentionally generic; it does not require that its **this** value be a String object. Therefore, it can be transferred to other kinds of objects for use as a method.

#### 15.5.4.5 **String.prototype.charCodeAt (pos)**

Returns a number (a nonnegative integer less than 2<sup>16</sup>) representing the code point value of the character at position *pos* in the string resulting from converting this object to a string. If there is no character at that position, the result is **NaN**.

When the **charCodeAt** method is called with one argument *pos*, the following steps are taken:

1. Call **ToString**, giving it the **this** value as its argument.
2. Call **ToInteger(pos)**.
3. Compute the number of characters in **Result(1)**.
4. If **Result(2)** is less than 0 or is not less than **Result(3)**, return **NaN**.
5. Return a value of Number type, whose value is the code point value of the character at position **Result(2)** in the string **Result(1)**, where the first (leftmost) character in **Result(1)** is considered to be at position 0, the next one at position 1, and so on.

#### NOTE

The **charCodeAt** function is intentionally generic; it does not require that its **this** value be a String object. Therefore it can be transferred to other kinds of objects for use as a method.

#### 15.5.4.6 **String.prototype.concat ( [ string1 [ , string2 [ , ... ] ] ] )**

When the **concat** method is called with zero or more arguments *string1*, *string2*, etc., it returns a string consisting of the characters of this object (converted to a string) followed by the characters of each of *string1*, *string2*, etc. (where each argument is converted to a string). The result is a string value, not a String object. The following steps are taken:

1. Call **ToString**, giving it the **this** value as its argument.
2. Let *R* be **Result(1)**.

3. Get the next argument in the argument list; if there are no more arguments, go to step 7.
4. Call ToString(Result(3)).
5. Let *R* be the string value consisting of the characters in the previous value of *R* followed by the characters Result(4).
6. Go to step 3.
7. Return *R*.

The **length** property of the **concat** method is **1**.

**NOTE**

The **concat** function is intentionally generic; it does not require that its **this** value be a String object. Therefore it can be transferred to other kinds of objects for use as a method.

**15.5.4.7 String.prototype.indexOf (searchString, position)**

If *searchString* appears as a substring of the result of converting this object to a string, at one or more positions that are greater than or equal to *position*, then the index of the smallest such position is returned; otherwise, **-1** is returned. If *position* is **undefined**, 0 is assumed, so as to search all of the string.

The **indexOf** method takes two arguments, *searchString* and *position*, and performs the following steps:

1. Call ToString, giving it the **this** value as its argument.
2. Call ToString(*searchString*).
3. Call ToInteger(*position*). (If *position* is **undefined**, this step produces the value **0**).
4. Compute the number of characters in Result(1).
5. Compute min(max(Result(3), 0), Result(4)).
6. Compute the number of characters in the string that is Result(2).
7. Compute the smallest possible integer *k* not smaller than Result(5) such that *k*+Result(6) is not greater than Result(4), and for all nonnegative integers *j* less than Result(6), the character at position *k*+*j* of Result(1) is the same as the character at position *j* of Result(2); but if there is no such integer *k*, then compute the value **-1**.
8. Return Result(7).

The **length** property of the **indexOf** method is **1**.

**NOTE**

The **indexOf** function is intentionally generic; it does not require that its **this** value be a String object. Therefore, it can be transferred to other kinds of objects for use as a method.

**15.5.4.8 String.prototype.lastIndexOf (searchString, position)**

If *searchString* appears as a substring of the result of converting this object to a string at one or more positions that are smaller than or equal to *position*, then the index of the greatest such position is returned; otherwise, **-1** is returned. If *position* is **undefined**, the length of the string value is assumed, so as to search all of the string.

The **lastIndexOf** method takes two arguments, *searchString* and *position*, and performs the following steps:

1. Call ToString, giving it the **this** value as its argument.
2. Call ToString(*searchString*).
3. Call ToNumber(*position*). (If *position* is **undefined**, this step produces the value **NaN**).
4. If Result(3) is **NaN**, use **+∞**; otherwise, call ToInteger(Result(3)).
5. Compute the number of characters in Result(1).
6. Compute min(max(Result(4), 0), Result(5)).
7. Compute the number of characters in the string that is Result(2).
8. Compute the largest possible nonnegative integer *k* not larger than Result(6) such that *k*+Result(7) is not greater than Result(5), and for all nonnegative integers *j* less than Result(7), the character at position *k*+*j* of Result(1) is the same as the character at position *j* of Result(2); but if there is no such integer *k*, then compute the value **-1**.
9. Return Result(8).

The **length** property of the **lastIndexOf** method is 1.

**NOTE**

The **lastIndexOf** function is intentionally generic; it does not require that its **this** value be a *String* object. Therefore, it can be transferred to other kinds of objects for use as a method.

**15.5.4.9 String.prototype.localeCompare (that)**

When the **localeCompare** method is called with one argument *that*, it returns a number other than **NaN** that represents the result of a locale-sensitive string comparison of this object (converted to a string) with *that* (converted to a string). The two strings are compared in an implementation-defined fashion. The result is intended to order strings in the sort order specified by the system default locale, and will be negative, zero, or positive, depending on whether **this** comes before *that* in the sort order, the strings are equal, or **this** comes after *that* in the sort order, respectively.

The **localeCompare** method, if considered as a function of two arguments **this** and *that*, is a consistent comparison function (as defined in 15.4.4.11) on the set of all strings. Furthermore, **localeCompare** returns 0 or -0 when comparing two strings that are considered canonically equivalent by the Unicode standard.

The actual return values are left implementation-defined to permit implementers to encode additional information in the result value, but the function is required to define a total ordering on all strings and to return 0 when comparing two strings that are considered canonically equivalent by the Unicode standard.

**NOTE 1**

The **localeCompare** method itself is not directly suitable as an argument to **Array.prototype.sort** because the latter requires a function of two arguments.

**NOTE 2**

This function is intended to rely on whatever language-sensitive comparison functionality is available to the ECMAScript environment from the host environment, and to compare according to the rules of the host environment's current locale. It is strongly recommended that this function treat strings that are canonically equivalent according to the Unicode standard as identical (in other words, compare the strings as if they had both been converted to Normalised Form C or D first). It is also recommended that this function not honour Unicode compatibility equivalences or decompositions.

If no language-sensitive comparison at all is available from the host environment, this function may perform a bitwise comparison.

**NOTE 3**

The **localeCompare** function is intentionally generic; it does not require that its **this** value be a *String* object. Therefore, it can be transferred to other kinds of objects for use as a method.

**NOTE 4**

The second parameter to this function is likely to be used in a future version of this standard; it is recommended that implementations do not use this parameter position for anything else.

**15.5.4.10 String.prototype.match (regexp)**

If *regexp* is not an object whose **[[Class]]** property is "**RegExp**", it is replaced with the result of the expression **new RegExp (regexp)**. Let *string* denote the result of converting the **this** value to a string. Then do one of the following:

If **regexp.global** is **false**: Return the result obtained by invoking **RegExp.prototype.exec** (see 15.10.6.2) on *regexp* with *string* as parameter.

If **regexp.global** is **true**: Set the **regexp.lastIndex** property to 0 and invoke **RegExp.prototype.exec** repeatedly until there is no match. If there is a match with an empty string (in other words, if the value of **regexp.lastIndex** is left unchanged), increment **regexp.lastIndex** by 1. Let *n* be the number of matches. If *n*=0, then the value returned is null; otherwise, the value returned is an array with the **length** property set to *n* and properties 0 through *n*-1 corresponding to the first elements of the results of all matching invocations of **RegExp.prototype.exec**.

pratapL 3/25/2008 1:21 AM

**Deleted:** The value returned is an array with the **length** property set to *n* and properties 0 through *n*-1 corresponding to the first elements of the results of all matching invocations of **RegExp.prototype.exec**.

**NOTE**

The **match** function is intentionally generic; it does not require that its **this** value be a *String* object. Therefore, it can be transferred to other kinds of objects for use as a method.

**15.5.4.11 String.prototype.replace (searchValue, replaceValue)**

Let *string* denote the result of converting the **this** value to a string.

If *searchValue* is a regular expression (an object whose `[[Class]]` property is **"RegExp"**), do the following: If *searchValue*.`global` is **false**, then search *string* for the first match of the regular expression *searchValue*. If *searchValue*.`global` is **true**, then search *string* for all matches of the regular expression *searchValue*. Do the search in the same manner as in **String.prototype.match**, including the update of *searchValue*.`lastIndex`. Let *m* be the number of left capturing parentheses in *searchValue* (*NcapturingParens* as specified in 15.10.2.1).

If *searchValue* is not a regular expression, let *searchString* be `ToString(searchValue)` and search *string* for the first occurrence of *searchString*. Let *m* be 0.

If *replaceValue* is a function, then for each matched substring, call the function with the following *m* + 3 arguments. Argument 1 is the substring that matched. If *searchValue* is a regular expression, the next *m* arguments are all of the captures in the `MatchResult` (see 15.10.2.1). Argument *m* + 2 is the offset within *string* where the match occurred, and argument *m* + 3 is *string*. The result is a string value derived from the original input by replacing each matched substring with the corresponding return value of the function call, converted to a string if need be.

Otherwise, let *newstring* denote the result of converting *replaceValue* to a string. The result is a string value derived from the original input string by replacing each matched substring with a string derived from *newstring* by replacing characters in *newstring* by replacement text as specified in the following table. These **\$** replacements are done left-to-right, and, once such a replacement is performed, the new replacement text is not subject to further replacements. For example, `"$1,$2".replace(/(\$(\d))/g, "$$1-$1$2")` returns `"$1-$11,$1-$22"`. A **\$** in *newstring* that does not match any of the forms below is left as is.

Characters	Replacement text
<b>\$\$</b>	<b>\$</b>
<b>\$&amp;</b>	The matched substring.
<b>\$^</b>	The portion of <i>string</i> that precedes the matched substring.
<b>\$'</b>	The portion of <i>string</i> that follows the matched substring.
<b>\$n</b>	The <i>n</i> th capture, where <i>n</i> is a single digit 1-9 and <b>\$n</b> is not followed by a decimal digit. If <i>n</i> ≤ <i>m</i> and the <i>n</i> th capture is <b>undefined</b> , use the empty string instead. If <i>n</i> > <i>m</i> , the result is implementation-defined.
<b>\$nn</b>	The <i>nn</i> <sup>th</sup> capture, where <i>nn</i> is a two-digit decimal number 01-99. If <i>nn</i> ≤ <i>m</i> and the <i>nn</i> <sup>th</sup> capture is <b>undefined</b> , use the empty string instead. If <i>nn</i> > <i>m</i> , the result is implementation-defined.

**NOTE**

The **replace** function is intentionally generic; it does not require that its **this** value be a *String* object. Therefore, it can be transferred to other kinds of objects for use as a method.

**15.5.4.12 String.prototype.search (regexp)**

If *regexp* is not an object whose `[[Class]]` property is **"RegExp"**, it is replaced with the result of the expression `new RegExp(regexp)`. Let *string* denote the result of converting the **this** value to a string.

The value *string* is searched from its beginning for an occurrence of the regular expression pattern *regexp*. The result is a number indicating the offset within the string where the pattern matched, or -1 if there was no match.



*NOTE 1*

*This method ignores the **lastIndex** and **global** properties of **regexp**. The **lastIndex** property of **regexp** is left unchanged.*

*NOTE 2*

*The **search** function is intentionally generic; it does not require that its **this** value be a **String** object. Therefore, it can be transferred to other kinds of objects for use as a method.*

**15.5.4.13 String.prototype.slice (start, end)**

The **slice** method takes two arguments, *start* and *end*, and returns a substring of the result of converting this object to a string, starting from character position *start* and running to, but not including, character position *end* (or through the end of the string if *end* is **undefined**). If *start* is negative, it is treated as (*sourceLength*+*start*) where *sourceLength* is the length of the string. If *end* is negative, it is treated as (*sourceLength*+*end*) where *sourceLength* is the length of the string. The result is a string value, not a **String** object. The following steps are taken:

1. Call **ToString**, giving it the **this** value as its argument.
2. Compute the number of characters in **Result(1)**.
3. Call **ToInteger**(*start*).
4. If *end* is **undefined**, use **Result(2)**; else use **ToInteger**(*end*).
5. If **Result(3)** is negative, use **max**(**Result(2)**+**Result(3)**,0); else use **min**(**Result(3)**,**Result(2)**).
6. If **Result(4)** is negative, use **max**(**Result(2)**+**Result(4)**,0); else use **min**(**Result(4)**,**Result(2)**).
7. Compute **max**(**Result(6)**-**Result(5)**,0).
8. Return a string containing **Result(7)** consecutive characters from **Result(1)** beginning with the character at position **Result(5)**.

The **length** property of the **slice** method is **2**.

*NOTE*

*The **slice** function is intentionally generic; it does not require that its **this** value be a **String** object. Therefore it can be transferred to other kinds of objects for use as a method.*

**15.5.4.14 String.prototype.split (separator, limit)**

Returns an **Array** object into which substrings of the result of converting this object to a string have been stored. The substrings are determined by searching from left to right for occurrences of *separator*; these occurrences are not part of any substring in the returned array, but serve to divide up the string value. The value of *separator* may be a string of any length or it may be a **RegExp** object (i.e., an object whose **[[Class]]** property is **"RegExp"**; see 15.10).

The value of *separator* may be an empty string, an empty regular expression, or a regular expression that can match an empty string. In this case, *separator* does not match the empty substring at the beginning or end of the input string, nor does it match the empty substring at the end of the previous separator match. (For example, if *separator* is the empty string, the string is split up into individual characters; the length of the result array equals the length of the string, and each substring contains one character.) If *separator* is a regular expression, only the first match at a given position of the **this** string is considered, even if backtracking could yield a non-empty-substring match at that position. (For example, **"ab".split(/a\*/)** evaluates to the array **["a","b"]**, while **"ab".split(/a\*/)** evaluates to the array **["","b"]**.)

If the **this** object is (or converts to) the empty string, the result depends on whether *separator* can match the empty string. If it can, the result array contains no elements. Otherwise, the result array contains one element, which is the empty string.

If *separator* is a regular expression that contains capturing parentheses, then each time *separator* is matched the results (including any **undefined** results) of the capturing parentheses are spliced into the output array. (For example,

**"A<B>bold</B>and<CODE>coded</CODE>".split(/<(\/?)([<>]+)/)** evaluates to the array **["A", undefined, "B", "bold", "/", "B", "and", undefined, "CODE", "coded", "/", "CODE", ""]**.)

If *separator* is **undefined**, then the result array contains just one string, which is the **this** value (converted to a string). If *limit* is not **undefined**, then the output array is truncated so that it contains no more than *limit* elements.

When the **split** method is called, the following steps are taken:

1. Let *S* = ToString(**this**).
2. Let *A* be a new array created as if by the expression **new Array()** [where Array is the standard built-in constructor with that name](#).
3. If *limit* is **undefined**, let *lim* =  $2^{32}-1$ ; else let *lim* = ToUint32(*limit*).
4. Let *s* be the number of characters in *S*.
5. Let *p* = 0.
6. If *separator* is a RegExp object (its [[Class]] is "**RegExp**"), let *R* = *separator*; otherwise let *R* = ToString(*separator*).
7. If *lim* = 0, return *A*.
8. If *separator* is **undefined**, go to step 33.
9. If *s* = 0, go to step 31.
10. Let *q* = *p*.
11. If *q* = *s*, go to step 28.
12. Call *SplitMatch*(*R*, *S*, *q*) and let *z* be its MatchResult result.
13. If *z* is **failure**, go to step 26.
14. *z* must be a State. Let *e* be *z*'s *endIndex* and let *cap* be *z*'s *captures* array.
15. If *e* = *p*, go to step 26.
16. Let *T* be a string value equal to the substring of *S* consisting of the characters at positions *p* (inclusive) through *q* (exclusive).
17. Call the [[Put]] method of *A* with arguments *A.length* and *T*.
18. If *A.length* = *lim*, return *A*.
19. Let *p* = *e*.
20. Let *i* = 0.
21. If *i* is equal to the number of elements in *cap*, go to step 10.
22. Let *i* = *i*+1.
23. Call the [[Put]] method of *A* with arguments *A.length* and *cap*[*i*].
24. If *A.length* = *lim*, return *A*.
25. Go to step 21.
26. Let *q* = *q*+1.
27. Go to step 11.
28. Let *T* be a string value equal to the substring of *S* consisting of the characters at positions *p* (inclusive) through *s* (exclusive).
29. Call the [[Put]] method of *A* with arguments *A.length* and *T*.
30. Return *A*.
31. Call *SplitMatch*(*R*, *S*, 0) and let *z* be its MatchResult result.
32. If *z* is not **failure**, return *A*.
33. Call the [[Put]] method of *A* with arguments "0" and *S*.
34. Return *A*.

The internal helper function *SplitMatch* takes three parameters, a string *S*, an integer *q*, and a string or RegExp *R*, and performs the following in order to return a MatchResult (see 15.10.2.1):

1. If *R* is a RegExp object (its [[Class]] is "**RegExp**"), go to step 8.
2. *R* must be a string. Let *r* be the number of characters in *R*.
3. Let *s* be the number of characters in *S*.
4. If  $q+r > s$  then return the MatchResult **failure**.
5. If there exists an integer *i* between 0 (inclusive) and *r* (exclusive) such that the character at position  $q+i$  of *S* is different from the character at position *i* of *R*, then return **failure**.
6. Let *cap* be an empty array of captures (see 15.10.2.1).
7. Return the State ( $q+r$ , *cap*). (see 15.10.2.1)
8. Call the [[Match]] method of *R* giving it the arguments *S* and *q*, and return the MatchResult result.

The **length** property of the **split** method is 2.

*NOTE 1*

The **split** function is intentionally generic; it does not require that its **this** value be a String object. Therefore, it can be transferred to other kinds of objects for use as a method.

*NOTE 2*

The **split** method ignores the value of separator **.global** for separators that are RegExp objects.

**15.5.4.15 String.prototype.substring (start, end)**

The **substring** method takes two arguments, *start* and *end*, and returns a substring of the result of converting this object to a string, starting from character position *start* and running to, but not including, character position *end* of the string (or through the end of the string if *end* is **undefined**). The result is a string value, not a String object.

If either argument is NaN or negative, it is replaced with zero; if either argument is larger than the length of the string, it is replaced with the length of the string.

If *start* is larger than *end*, they are swapped.

The following steps are taken:

1. Call ToString, giving it the **this** value as its argument.
2. Compute the number of characters in Result(1).
3. Call ToInteger(*start*).
4. If *end* is **undefined**, use Result(2); else use ToInteger(*end*).
5. Compute min(max(Result(3), 0), Result(2)).
6. Compute min(max(Result(4), 0), Result(2)).
7. Compute min(Result(5), Result(6)).
8. Compute max(Result(5), Result(6)).
9. Return a string whose length is the difference between Result(8) and Result(7), containing characters from Result(1), namely the characters with indices Result(7) through Result(8)-1, in ascending order.

The **length** property of the **substring** method is 2.

*NOTE*

The **substring** function is intentionally generic; it does not require that its **this** value be a String object. Therefore, it can be transferred to other kinds of objects for use as a method.

**15.5.4.16 String.prototype.toLowerCase ( )**

If this object is not already a string, it is converted to a string. The characters in that string are converted one by one to lower case. The result is a string value, not a String object.

The characters are converted one by one. The result of each conversion is the original character, unless that character has a Unicode lowercase equivalent, in which case the lowercase equivalent is used instead.

*NOTE 1*

The result should be derived according to the case mappings in the Unicode character database (this explicitly includes not only the UnicodeData.txt file, but also the SpecialCasings.txt file that accompanies it in Unicode 2.1.8 and later).

*NOTE 2*

The **toLowerCase** function is intentionally generic; it does not require that its **this** value be a String object. Therefore, it can be transferred to other kinds of objects for use as a method.

**15.5.4.17 String.prototype.toLocaleLowerCase ( )**

This function works exactly the same as **toLowerCase** except that its result is intended to yield the correct result for the host environment's current locale, rather than a locale-independent result. There will only be a difference in the few cases (such as Turkish) where the rules for that language conflict with the regular Unicode case mappings.

*NOTE 1*

The **toLocaleLowerCase** function is intentionally generic; it does not require that its **this** value be a String object. Therefore, it can be transferred to other kinds of objects for use as a method.

NOTE 2

The first parameter to this function is likely to be used in a future version of this standard; it is recommended that implementations do not use this parameter position for anything else.

15.5.4.18 **String.prototype.toUpperCase ( )**

This function behaves in exactly the same way as **String.prototype.toLowerCase**, except that characters are mapped to their *uppercase* equivalents as specified in the Unicode Character Database.

NOTE 1

Because both **toUpperCase** and **toLowerCase** have context-sensitive behaviour, the functions are not symmetrical. In other words, *s.toUpperCase().toLowerCase()* is not necessarily equal to *s.toLowerCase()*.

NOTE 2

The **toUpperCase** function is intentionally generic; it does not require that its **this** value be a String object. Therefore, it can be transferred to other kinds of objects for use as a method.

15.5.4.19 **String.prototype.toLocaleUpperCase ( )**

This function works exactly the same as **toUpperCase** except that its result is intended to yield the correct result for the host environment's current locale, rather than a locale-independent result. There will only be a difference in the few cases (such as Turkish) where the rules for that language conflict with the regular Unicode case mappings.

NOTE 1

The **toLocaleUpperCase** function is intentionally generic; it does not require that its **this** value be a String object. Therefore, it can be transferred to other kinds of objects for use as a method.

NOTE 2

The first parameter to this function is likely to be used in a future version of this standard; it is recommended that implementations do not use this parameter position for anything else.

15.5.4.20 **String.prototype.trim ( )**

If this object is not already a string, it is converted to a string. The result is a copy of the string with both leading and trailing white space removed. The definition of white space is the union of WhiteSpace and LineTerminator. The result is a string value, not a String object.

NOTE

The **trim** function is intentionally generic; it does not require that its **this** value be a String object. Therefore, it can be transferred to other kinds of objects for use as a method.

15.5.5 **Properties of String Instances**

String instances inherit properties from the String prototype object and also have a **[[PrimitiveValue]]** property and a **length** property.

The **[[PrimitiveValue]]** property is the string value represented by this String object.

15.5.5.1 **length**

The number of characters in the String value represented by this String object.

Once a String object is created, this property is unchanging. It has the attributes { **[[Writable]]**: **false**, **[[Enumerable]]**: **false**, **[[Flexible]]**: **false** }.

15.5.5.2 **[[GetOwnProperty]] ( P )**

String objects use a variation of the **[[GetOwnProperty]]** method used for other native ECMAScript objects (8.6.2.8).

Assume *S* is a String object and *P* is a string.

When the **[[GetOwnProperty]]** method of *S* is called with property name *P*, the following steps are taken:

1. Call the default **[[GetOwnProperty]]** method (8.6.2.8) with *S* as the **this** value and argument *P*.
2. If Result(1) is not **undefined** return Result(1).

3. [If P is not an array index \(15.4\), return \*\*undefined\*\*.](#)
4. [Call `ToString`, giving \*S\* as its argument.](#)
5. [Call `ToInteger\(P\)`.](#)
6. [Compute the number of characters in `Result\(4\)`.](#)
7. [If `Result\(5\)` is less than 0 or is not less than `Result\(6\)`, return \*\*undefined\*\*.](#)
8. [Create a string of length \*l\*, containing one character from `Result\(4\)`, namely the character at position `Result\(5\)`, where the first \(leftmost\) character in `Result\(4\)` is considered to be at position 0, the next one at position 1, and so on.](#)
9. [Return a Property Descriptor { `\[\[Value\]\]`: `Result\(8\)`, `\[\[Enumerable\]\]`: \*\*false\*\*, `\[\[Writable\]\]`: \*\*false\*\*, `\[\[Flexible\]\]`: \*\*false\*\* }](#)

## 15.6 Boolean Objects

### 15.6.1 The Boolean Constructor Called as a Function

When **Boolean** is called as a function rather than as a constructor, it performs a type conversion.

#### 15.6.1.1 Boolean (value)

Returns a boolean value (not a Boolean object) computed by `ToBoolean(value)`.

### 15.6.2 The Boolean Constructor

When **Boolean** is called as part of a **new** expression it is a constructor: it initialises the newly created object.

#### 15.6.2.1 new Boolean (value)

The `[[Prototype]]` property of the newly constructed object is set to the original Boolean prototype object, the one that is the initial value of `Boolean.prototype` (15.6.3.1).

The `[[Class]]` property of the newly constructed Boolean object is set to **"Boolean"**.

The `[[PrimitiveValue]]` property of the newly constructed Boolean object is set to `ToBoolean(value)`.

[The `\[\[Extensible\]\]` property of the newly constructed object is set to \*\*true\*\*.](#)

### 15.6.3 Properties of the Boolean Constructor

The value of the internal `[[Prototype]]` property of the Boolean constructor is the Function prototype object (15.3.4).

Besides the internal properties and the `length` property (whose value is 1), the Boolean constructor has the following property:

#### 15.6.3.1 Boolean.prototype

The initial value of `Boolean.prototype` is the Boolean prototype object (15.6.4).

This property has the attributes { `[[Writable]]`: **false**, `[[Enumerable]]`: **false**, `[[Flexible]]`: **false** }.

### 15.6.4 Properties of the Boolean Prototype Object

The Boolean prototype object is itself a Boolean object (its `[[Class]]` is **"Boolean"**) whose value is **false**.

The value of the internal `[[Prototype]]` property of the Boolean prototype object is the Object prototype object (15.2.3.1).

In following descriptions of functions that are properties of the Boolean prototype object, the phrase "this Boolean object" refers to the object that is the **this** value for the invocation of the function; a **TypeError** exception is thrown if the **this** value is not an object for which the value of the internal `[[Class]]` property is **"Boolean"**. Also, the phrase "this boolean value" refers to the boolean value represented by this Boolean object, that is, the value of the internal `[[PrimitiveValue]]` property of this Boolean object.

#### 15.6.4.1 Boolean.prototype.constructor

The initial value of `Boolean.prototype.constructor` is the built-in **Boolean** constructor.

pratapL 5/29/2008 12:34 AM

Deleted: DontEnum, DontDelete, ReadOnly

#### 15.6.4.2 Boolean.prototype.toString ( )

If this boolean value is **true**, then the string "**true**" is returned. Otherwise, this boolean value must be **false**, and the string "**false**" is returned.

The **toString** function is not generic; it throws a **TypeError** exception if its **this** value is not a Boolean object. Therefore, it cannot be transferred to other kinds of objects for use as a method.

#### 15.6.4.3 Boolean.prototype.valueOf ( )

Returns this boolean value.

The **valueOf** function is not generic; it throws a **TypeError** exception if its **this** value is not a Boolean object. Therefore, it cannot be transferred to other kinds of objects for use as a method.

#### 15.6.5 Properties of Boolean Instances

Boolean instances have no special properties beyond those inherited from the Boolean prototype object.

### 15.7 Number Objects

#### 15.7.1 The Number Constructor Called as a Function

When **Number** is called as a function rather than as a constructor, it performs a type conversion.

##### 15.7.1.1 Number ( [ value ] )

Returns a number value (not a Number object) computed by `ToNumber(value)` if *value* was supplied, else returns `+0`.

#### 15.7.2 The Number Constructor

When **Number** is called as part of a **new** expression it is a constructor: it initialises the newly created object.

##### 15.7.2.1 new Number ( [ value ] )

The `[[Prototype]]` property of the newly constructed object is set to the original Number prototype object, the one that is the initial value of **Number.prototype** (15.7.3.1).

The `[[Class]]` property of the newly constructed object is set to "**Number**".

The `[[PrimitiveValue]]` property of the newly constructed object is set to `ToNumber(value)` if *value* was supplied, else to `+0`.

[The `\[\[Extensible\]\]` property of the newly constructed object is set to `true`.](#)

#### 15.7.3 Properties of the Number Constructor

The value of the internal `[[Prototype]]` property of the Number constructor is the Function prototype object (15.3.4).

Besides the internal properties and the **length** property (whose value is **1**), the Number constructor has the following property:

##### 15.7.3.1 Number.prototype

The initial value of **Number.prototype** is the Number prototype object (15.7.4).

This property has the attributes { `[[Writable]]: false, [[Enumerable]]: false, [[Flexible]]: false` }.

##### 15.7.3.2 Number.MAX\_VALUE

The value of **Number.MAX\_VALUE** is the largest positive finite value of the number type, which is approximately  $1.7976931348623157 \times 10^{308}$ .

This property has the attributes { `[[Writable]]: false, [[Enumerable]]: false, [[Flexible]]: false` }.

##### 15.7.3.3 Number.MIN\_VALUE

The value of **Number.MIN\_VALUE** is the smallest positive value of the number type, which is approximately  $5 \times 10^{-324}$ .

This property has the attributes { `[[Writable]]: false, [[Enumerable]]: false, [[Flexible]]: false` }.

pratapL 5/29/2008 12:35 AM  
Deleted: DontEnum, DontDelete, ReadOnly

pratapL 5/29/2008 12:35 AM  
Deleted: DontEnum, DontDelete, ReadOnly

pratapL 5/29/2008 12:35 AM  
Deleted: DontEnum, DontDelete, ReadOnly

- 15.7.3.4 Number.NaN**

The value of `Number.NaN` is NaN.

This property has the attributes { `[[Writable]]: false, [[Enumerable]]: false, [[Flexible]]: false` }.
- 15.7.3.5 Number.NEGATIVE\_INFINITY**

The value of `Number.NEGATIVE_INFINITY` is  $-\infty$ .

This property has the attributes { `[[Writable]]: false, [[Enumerable]]: false, [[Flexible]]: false` }.
- 15.7.3.6 Number.POSITIVE\_INFINITY**

The value of `Number.POSITIVE_INFINITY` is  $+\infty$ .

This property has the attributes { `[[Writable]]: false, [[Enumerable]]: false, [[Flexible]]: false` }.
- 15.7.4 Properties of the Number Prototype Object**

The Number prototype object is itself a Number object (its `[[Class]]` is `"Number"`) whose value is  $+0$ .

The value of the internal `[[Prototype]]` property of the Number prototype object is the Object prototype object (15.2.3.1).

In following descriptions of functions that are properties of the Number prototype object, the phrase “this Number object” refers to the object that is the `this` value for the invocation of the function; a `TypeError` exception is thrown if the `this` value is not an object for which the value of the internal `[[Class]]` property is `"Number"`. Also, the phrase “this number value” refers to the number value represented by this Number object, that is, the value of the internal `[[PrimitiveValue]]` property of this Number object.

  - 15.7.4.1 Number.prototype.constructor**

The initial value of `Number.prototype.constructor` is the built-in `Number` constructor.
  - 15.7.4.2 Number.prototype.toString (radix)**

If `radix` is the number 10 or `undefined`, then this number value is given as an argument to the `ToString` operator; the resulting string value is returned.

If `radix` is an integer from 2 to 36, but not 10, the result is a string, the choice of which is implementation-dependent.

The `toString` function is not generic; it throws a `TypeError` exception if its `this` value is not a Number object. Therefore, it cannot be transferred to other kinds of objects for use as a method.
  - 15.7.4.3 Number.prototype.toLocaleString()**

Produces a string value that represents the value of the Number formatted according to the conventions of the host environment’s current locale. This function is implementation-dependent, and it is permissible, but not encouraged, for it to return the same thing as `toString`.

*NOTE*  
The first parameter to this function is likely to be used in a future version of this standard; it is recommended that implementations do not use this parameter position for anything else.
  - 15.7.4.4 Number.prototype.valueOf ()**

Returns this number value.

The `valueOf` function is not generic; it throws a `TypeError` exception if its `this` value is not a Number object. Therefore, it cannot be transferred to other kinds of objects for use as a method.
  - 15.7.4.5 Number.prototype.toFixed (fractionDigits)**

Return a string containing the number represented in fixed-point notation with `fractionDigits` digits after the decimal point. If `fractionDigits` is `undefined`, 0 is assumed. Specifically, perform the following steps:

    1. Let `f` be `ToInteger(fractionDigits)`. (If `fractionDigits` is `undefined`, this step produces the value 0).
    2. If `f < 0` or `f > 20`, throw a `RangeError` exception.
    3. Let `x` be this number value.

pratapL 5/29/2008 12:36 AM  
Deleted: DontEnum, DontDelete, ReadOnly

pratapL 5/29/2008 12:36 AM  
Deleted: DontEnum, DontDelete, ReadOnly

pratapL 5/29/2008 12:36 AM  
Deleted: DontEnum, DontDelete, ReadOnly

4. If  $x$  is **NaN**, return the string "**NaN**".
5. Let  $s$  be the empty string.
6. If  $x \geq 0$ , go to step 9.
7. Let  $s$  be "-".
8. Let  $x = -x$ .
9. If  $x \geq 10^{21}$ , let  $m = \text{ToString}(x)$  and go to step 20.
10. Let  $n$  be an integer for which the exact mathematical value of  $n \div 10^f - x$  is as close to zero as possible. If there are two such  $n$ , pick the larger  $n$ .
11. If  $n = 0$ , let  $m$  be the string "**0**". Otherwise, let  $m$  be the string consisting of the digits of the decimal representation of  $n$  (in order, with no leading zeroes).
12. If  $f = 0$ , go to step 20.
13. Let  $k$  be the number of characters in  $m$ .
14. If  $k > f$ , go to step 18.
15. Let  $z$  be the string consisting of  $f+1-k$  occurrences of the character '0'.
16. Let  $m$  be the concatenation of strings  $z$  and  $m$ .
17. Let  $k = f + 1$ .
18. Let  $a$  be the first  $k-f$  characters of  $m$ , and let  $b$  be the remaining  $f$  characters of  $m$ .
19. Let  $m$  be the concatenation of the three strings  $a$ , ".", and  $b$ .
20. Return the concatenation of the strings  $s$  and  $m$ .

The **length** property of the **toFixed** method is **1**.

If the **toFixed** method is called with more than one argument, then the behaviour is undefined (see clause 15).

An implementation is permitted to extend the behaviour of **toFixed** for values of *fractionDigits* less than 0 or greater than 20. In this case **toFixed** would not necessarily throw **RangeError** for such values.

**NOTE**

The output of **toFixed** may be more precise than **toString** for some values because **toString** only prints enough significant digits to distinguish the number from adjacent number values. For example, `(100000000000000128).toString()` returns `"100000000000000100"`, while `(100000000000000128).toFixed(0)` returns `"100000000000000128"`.

**15.7.4.6 Number.prototype.toExponential (fractionDigits)**

Return a string containing the number represented in exponential notation with one digit before the significand's decimal point and *fractionDigits* digits after the significand's decimal point. If *fractionDigits* is **undefined**, include as many significand digits as necessary to uniquely specify the number (just like in **ToString** except that in this case the number is always output in exponential notation). Specifically, perform the following steps:

1. Let  $x$  be this number value.
2. Let  $f$  be **ToInteger**(*fractionDigits*).
3. If  $x$  is **NaN**, return the string "**NaN**".
4. Let  $s$  be the empty string.
5. If  $x \geq 0$ , go to step 8.
6. Let  $s$  be "-".
7. Let  $x = -x$ .
8. If  $x = +\infty$ , let  $m = \text{"Infinity"}$  and go to step 30.
9. If *fractionDigits* is **undefined**, go to step 14.
10. If  $f < 0$  or  $f > 20$ , throw a **RangeError** exception.
11. If  $x = 0$ , go to step 16.
12. Let  $e$  and  $n$  be integers such that  $10^e \leq n < 10^{e+1}$  and for which the exact mathematical value of  $n \times 10^{e-f} - x$  is as close to zero as possible. If there are two such sets of  $e$  and  $n$ , pick the  $e$  and  $n$  for which  $n \times 10^{e-f}$  is larger.
13. Go to step 20.
14. If  $x \neq 0$ , go to step 19.
15. Let  $f = 0$ .



16. Let  $m$  be the string consisting of  $f+1$  occurrences of the character '0'.
  17. Let  $e = 0$ .
  18. Go to step 21.
  19. Let  $e$ ,  $n$ , and  $f$  be integers such that  $f \geq 0$ ,  $10^f \leq n < 10^{f+1}$ , the number value for  $n \times 10^{e-f}$  is  $x$ , and  $f$  is as small as possible. Note that the decimal representation of  $n$  has  $f+1$  digits,  $n$  is not divisible by 10, and the least significant digit of  $n$  is not necessarily uniquely determined by these criteria.
  20. Let  $m$  be the string consisting of the digits of the decimal representation of  $n$  (in order, with no leading zeroes).
  21. If  $f = 0$ , go to step 24.
  22. Let  $a$  be the first character of  $m$ , and let  $b$  be the remaining  $f$  characters of  $m$ .
  23. Let  $m$  be the concatenation of the three strings  $a$ , ".", and  $b$ .
  24. If  $e = 0$ , let  $c = "+"$  and  $d = "0"$  and go to step 29.
  25. If  $e > 0$ , let  $c = "+"$  and go to step 28.
  26. Let  $c = "-"$ .
  27. Let  $e = -e$ .
  28. Let  $d$  be the string consisting of the digits of the decimal representation of  $e$  (in order, with no leading zeroes).
  29. Let  $m$  be the concatenation of the four strings  $m$ , "**e**",  $c$ , and  $d$ .
  30. Return the concatenation of the strings  $s$  and  $m$ .
- The **length** property of the **toExponential** method is 1.

If the **toExponential** method is called with more than one argument, then the behaviour is undefined (see clause 15).

An implementation is permitted to extend the behaviour of **toExponential** for values of *fractionDigits* less than 0 or greater than 20. In this case **toExponential** would not necessarily throw **RangeError** for such values.

**NOTE**

*For implementations that provide more accurate conversions than required by the rules above, it is recommended that the following alternative version of step 19 be used as a guideline:*

*Let  $e$ ,  $n$ , and  $f$  be integers such that  $f \geq 0$ ,  $10^f \leq n < 10^{f+1}$ , the number value for  $n \times 10^{e-f}$  is  $x$ , and  $f$  is as small as possible. If there are multiple possibilities for  $n$ , choose the value of  $n$  for which  $n \times 10^{e-f}$  is closest in value to  $x$ . If there are two such possible values of  $n$ , choose the one that is even.*

**15.7.4.7 Number.prototype.toPrecision (precision)**

Return a string containing the number represented either in exponential notation with one digit before the significand's decimal point and *precision*-1 digits after the significand's decimal point or in fixed notation with *precision* significant digits. If *precision* is **undefined**, call **ToString** (9.8.1) instead. Specifically, perform the following steps:

1. Let  $x$  be this number value.
2. If *precision* is **undefined**, return **ToString**( $x$ ).
3. Let  $p$  be **ToInteger**(*precision*).
4. If  $x$  is **NaN**, return the string "**NaN**".
5. Let  $s$  be the empty string.
6. If  $x \geq 0$ , go to step 9.
7. Let  $s$  be "-".
8. Let  $x = -x$ .
9. If  $x = +\infty$ , let  $m = "$ **Infinity** $"$  and go to step 30.
10. If  $p < 1$  or  $p > 21$ , throw a **RangeError** exception.
11. If  $x \neq 0$ , go to step 15.
12. Let  $m$  be the string consisting of  $p$  occurrences of the character '0'.
13. Let  $e = 0$ .
14. Go to step 18.
15. Let  $e$  and  $n$  be integers such that  $10^{e-1} \leq n < 10^e$  and for which the exact mathematical value of  $n \times 10^{e-p+1} - x$  is as close to zero as possible. If there are two such sets of  $e$  and  $n$ , pick the  $e$  and  $n$  for which  $n \times 10^{e-p+1}$  is larger.

16. Let  $m$  be the string consisting of the digits of the decimal representation of  $n$  (in order, with no leading zeroes).
17. If  $e < -6$  or  $e \geq p$ , go to step 22.
18. If  $e = p-1$ , go to step 30.
19. If  $e \geq 0$ , let  $m$  be the concatenation of the first  $e+1$  characters of  $m$ , the character '.', and the remaining  $p-(e+1)$  characters of  $m$  and go to step 30.
20. Let  $m$  be the concatenation of the string "0.",  $-(e+1)$  occurrences of the character '0', and the string  $m$ .
21. Go to step 30.
22. Let  $a$  be the first character of  $m$ , and let  $b$  be the remaining  $p-1$  characters of  $m$ .
23. Let  $m$  be the concatenation of the three strings  $a$ , ".", and  $b$ .
24. If  $e = 0$ , let  $c = "+"$  and  $d = "0"$  and go to step 29.
25. If  $e > 0$ , let  $c = "+"$  and go to step 28.
26. Let  $c = "-"$ .
27. Let  $e = -e$ .
28. Let  $d$  be the string consisting of the digits of the decimal representation of  $e$  (in order, with no leading zeroes).
29. Let  $m$  be the concatenation of the four strings  $m$ , "e",  $c$ , and  $d$ .
30. Return the concatenation of the strings  $s$  and  $m$ .

The **length** property of the **toPrecision** method is **1**.

If the **toPrecision** method is called with more than one argument, then the behaviour is undefined (see clause 15).

An implementation is permitted to extend the behaviour of **toPrecision** for values of *precision* less than 1 or greater than 21. In this case **toPrecision** would not necessarily throw **RangeError** for such values.

### 15.7.5 Properties of Number Instances

Number instances have no special properties beyond those inherited from the Number prototype object.

### 15.8 The Math Object

The Math object is a single object that has some named properties, some of which are functions.

The value of the internal **[[Prototype]]** property of the Math object is the Object prototype object (15.2.3.1). The value of the internal **[[Class]]** property of the Math object is **"Math"**.

The Math object does not have a **[[Construct]]** property; it is not possible to use the Math object as a constructor with the **new** operator.

The Math object does not have a **[[Call]]** property; it is not possible to invoke the Math object as a function.

#### NOTE

In this specification, the phrase "the number value for  $x$ " has a technical meaning defined in 8.5.

### 15.8.1 Value Properties of the Math Object

#### 15.8.1.1 E

The number value for  $e$ , the base of the natural logarithms, which is approximately 2.7182818284590452354.

This property has the attributes { **[[Writable]]: false, [[Enumerable]]: false, [[Flexible]]: false** }.

#### 15.8.1.2 LN10

The number value for the natural logarithm of 10, which is approximately 2.302585092994046.

This property has the attributes { **[[Writable]]: false, [[Enumerable]]: false, [[Flexible]]: false** }.

#### 15.8.1.3 LN2

The number value for the natural logarithm of 2, which is approximately 0.6931471805599453.

This property has the attributes { **[[Writable]]: false, [[Enumerable]]: false, [[Flexible]]: false** }.

pratapL 5/29/2008 12:37 AM  
Deleted: DontEnum, DontDelete, ReadOnly

pratapL 5/29/2008 12:37 AM  
Deleted: DontEnum, DontDelete, ReadOnly

pratapL 5/29/2008 12:37 AM  
Deleted: DontEnum, DontDelete, ReadOnly

15.8.1.4 LOG2E

The number value for the base-2 logarithm of *e*, the base of the natural logarithms; this value is approximately 1.4426950408889634.

This property has the attributes { [[Writable]]: false, [[Enumerable]]: false, [[Flexible]]: false }.

NOTE

The value of `Math.LOG2E` is approximately the reciprocal of the value of `Math.LN2`.

pratapL 5/29/2008 12:38 AM  
Deleted: DontEnum, DontDelete, ReadOnly

15.8.1.5 LOG10E

The number value for the base-10 logarithm of *e*, the base of the natural logarithms; this value is approximately 0.4342944819032518.

This property has the attributes { [[Writable]]: false, [[Enumerable]]: false, [[Flexible]]: false }.

NOTE

The value of `Math.LOG10E` is approximately the reciprocal of the value of `Math.LN10`.

pratapL 5/29/2008 12:38 AM  
Deleted: DontEnum, DontDelete, ReadOnly

15.8.1.6 PI

The number value for  $\pi$ , the ratio of the circumference of a circle to its diameter, which is approximately 3.1415926535897932.

This property has the attributes { [[Writable]]: false, [[Enumerable]]: false, [[Flexible]]: false }.

pratapL 5/29/2008 12:38 AM  
Deleted: DontEnum, DontDelete, ReadOnly

15.8.1.7 SQRT1\_2

The number value for the square root of 1/2, which is approximately 0.7071067811865476.

This property has the attributes { [[Writable]]: false, [[Enumerable]]: false, [[Flexible]]: false }.

NOTE

The value of `Math.SQRT1_2` is approximately the reciprocal of the value of `Math.SQRT2`.

pratapL 5/29/2008 12:38 AM  
Deleted: DontEnum, DontDelete, ReadOnly

15.8.1.8 SQRT2

The number value for the square root of 2, which is approximately 1.4142135623730951.

This property has the attributes { [[Writable]]: false, [[Enumerable]]: false, [[Flexible]]: false }.

pratapL 5/29/2008 12:38 AM  
Deleted: DontEnum, DontDelete, ReadOnly

15.8.2 Function Properties of the Math Object

Every function listed in this section applies the `ToNumber` operator to each of its arguments (in left-to-right order if there is more than one) and then performs a computation on the resulting number value(s).

In the function descriptions below, the symbols `NaN`, `-0`, `+0`, `-∞` and `+∞` refer to the number values described in 8.5.

NOTE

The behaviour of the functions `acos`, `asin`, `atan`, `atan2`, `cos`, `exp`, `log`, `pow`, `sin`, and `sqrt` is not precisely specified here except to require specific results for certain argument values that represent boundary cases of interest. For other argument values, these functions are intended to compute approximations to the results of familiar mathematical functions, but some latitude is allowed in the choice of approximation algorithms. The general intent is that an implementer should be able to use the same mathematical library for ECMAScript on a given hardware platform that is available to C programmers on that platform.

Although the choice of algorithms is left to the implementation, it is recommended (but not specified by this standard) that implementations use the approximation algorithms for IEEE 754 arithmetic contained in `fdlibm`, the freely distributable mathematical library from Sun Microsystems ([fdlibm-comment@sunpro.eng.sun.com](mailto:fdlibm-comment@sunpro.eng.sun.com)). This specification also requires specific results for certain argument values that represent boundary cases of interest

15.8.2.1 abs (x)

Returns the absolute value of *x*; the result has the same magnitude as *x* but has positive sign.

If *x* is `NaN`, the result is `NaN`.

If *x* is `-0`, the result is `+0`.

If  $x$  is  $-\infty$ , the result is  $+\infty$ .

**15.8.2.2 acos (x)**

Returns an implementation-dependent approximation to the arc cosine of  $x$ . The result is expressed in radians and ranges from  $+0$  to  $+\pi$ .

If  $x$  is NaN, the result is NaN.

If  $x$  is greater than 1, the result is NaN.

If  $x$  is less than  $-1$ , the result is NaN.

If  $x$  is exactly 1, the result is  $+0$ .

**15.8.2.3 asin (x)**

Returns an implementation-dependent approximation to the arc sine of  $x$ . The result is expressed in radians and ranges from  $-\pi/2$  to  $+\pi/2$ .

If  $x$  is NaN, the result is NaN.

If  $x$  is greater than 1, the result is NaN.

If  $x$  is less than  $-1$ , the result is NaN.

If  $x$  is  $+0$ , the result is  $+0$ .

If  $x$  is  $-0$ , the result is  $-0$ .

**15.8.2.4 atan (x)**

Returns an implementation-dependent approximation to the arc tangent of  $x$ . The result is expressed in radians and ranges from  $-\pi/2$  to  $+\pi/2$ .

If  $x$  is NaN, the result is NaN.

If  $x$  is  $+0$ , the result is  $+0$ .

If  $x$  is  $-0$ , the result is  $-0$ .

If  $x$  is  $+\infty$ , the result is an implementation-dependent approximation to  $+\pi/2$ .

If  $x$  is  $-\infty$ , the result is an implementation-dependent approximation to  $-\pi/2$ .

**15.8.2.5 atan2 (y, x)**

Returns an implementation-dependent approximation to the arc tangent of the quotient  $y/x$  of the arguments  $y$  and  $x$ , where the signs of  $y$  and  $x$  are used to determine the quadrant of the result. Note that it is intentional and traditional for the two-argument arc tangent function that the argument named  $y$  be first and the argument named  $x$  be second. The result is expressed in radians and ranges from  $-\pi$  to  $+\pi$ .

If either  $x$  or  $y$  is NaN, the result is NaN.

If  $y > 0$  and  $x$  is  $+0$ , the result is an implementation-dependent approximation to  $+\pi/2$ .

If  $y > 0$  and  $x$  is  $-0$ , the result is an implementation-dependent approximation to  $+\pi/2$ .

If  $y$  is  $+0$  and  $x > 0$ , the result is  $+0$ .

If  $y$  is  $+0$  and  $x$  is  $+0$ , the result is  $+0$ .

If  $y$  is  $+0$  and  $x$  is  $-0$ , the result is an implementation-dependent approximation to  $+\pi$ .

If  $y$  is  $+0$  and  $x < 0$ , the result is an implementation-dependent approximation to  $+\pi$ .

If  $y$  is  $-0$  and  $x > 0$ , the result is  $-0$ .

If  $y$  is  $-0$  and  $x$  is  $+0$ , the result is  $-0$ .

If  $y$  is  $-0$  and  $x$  is  $-0$ , the result is an implementation-dependent approximation to  $-\pi$ .

If  $y$  is  $-0$  and  $x < 0$ , the result is an implementation-dependent approximation to  $-\pi$ .

If  $y < 0$  and  $x$  is  $+0$ , the result is an implementation-dependent approximation to  $-\pi/2$ .

If  $y < 0$  and  $x$  is  $-0$ , the result is an implementation-dependent approximation to  $-\pi/2$ .

If  $y > 0$  and  $y$  is finite and  $x$  is  $+\infty$ , the result is  $+0$ .

If  $y > 0$  and  $y$  is finite and  $x$  is  $-\infty$ , the result is an implementation-dependent approximation to  $+\pi$ .

If  $y < 0$  and  $y$  is finite and  $x$  is  $+\infty$ , the result is  $-0$ .

If  $y < 0$  and  $y$  is finite and  $x$  is  $-\infty$ , the result is an implementation-dependent approximation to  $-\pi$ .  
If  $y$  is  $+\infty$  and  $x$  is finite, the result is an implementation-dependent approximation to  $+\pi/2$ .  
If  $y$  is  $-\infty$  and  $x$  is finite, the result is an implementation-dependent approximation to  $-\pi/2$ .  
If  $y$  is  $+\infty$  and  $x$  is  $+\infty$ , the result is an implementation-dependent approximation to  $+\pi/4$ .  
If  $y$  is  $+\infty$  and  $x$  is  $-\infty$ , the result is an implementation-dependent approximation to  $+3\pi/4$ .  
If  $y$  is  $-\infty$  and  $x$  is  $+\infty$ , the result is an implementation-dependent approximation to  $-\pi/4$ .  
If  $y$  is  $-\infty$  and  $x$  is  $-\infty$ , the result is an implementation-dependent approximation to  $-3\pi/4$ .

#### 15.8.2.6 **ceil (x)**

Returns the smallest (closest to  $-\infty$ ) number value that is not less than  $x$  and is equal to a mathematical integer. If  $x$  is already an integer, the result is  $x$ .

If  $x$  is NaN, the result is NaN.

If  $x$  is  $+0$ , the result is  $+0$ .

If  $x$  is  $-0$ , the result is  $-0$ .

If  $x$  is  $+\infty$ , the result is  $+\infty$ .

If  $x$  is  $-\infty$ , the result is  $-\infty$ .

If  $x$  is less than 0 but greater than  $-1$ , the result is  $-0$ .

The value of `Math.ceil(x)` is the same as the value of `-Math.floor(-x)`.

#### 15.8.2.7 **cos (x)**

Returns an implementation-dependent approximation to the cosine of  $x$ . The argument is expressed in radians.

If  $x$  is NaN, the result is NaN.

If  $x$  is  $+0$ , the result is 1.

If  $x$  is  $-0$ , the result is 1.

If  $x$  is  $+\infty$ , the result is NaN.

If  $x$  is  $-\infty$ , the result is NaN.

#### 15.8.2.8 **exp (x)**

Returns an implementation-dependent approximation to the exponential function of  $x$  ( $e$  raised to the power of  $x$ , where  $e$  is the base of the natural logarithms).

If  $x$  is NaN, the result is NaN.

If  $x$  is  $+0$ , the result is 1.

If  $x$  is  $-0$ , the result is 1.

If  $x$  is  $+\infty$ , the result is  $+\infty$ .

If  $x$  is  $-\infty$ , the result is  $+0$ .

#### 15.8.2.9 **floor (x)**

Returns the greatest (closest to  $+\infty$ ) number value that is not greater than  $x$  and is equal to a mathematical integer. If  $x$  is already an integer, the result is  $x$ .

If  $x$  is NaN, the result is NaN.

If  $x$  is  $+0$ , the result is  $+0$ .

If  $x$  is  $-0$ , the result is  $-0$ .

If  $x$  is  $+\infty$ , the result is  $+\infty$ .

If  $x$  is  $-\infty$ , the result is  $-\infty$ .

If  $x$  is greater than 0 but less than 1, the result is  $+0$ .

#### *NOTE*

*The value of `Math.floor(x)` is the same as the value of `-Math.ceil(-x)`.*

**15.8.2.10 log (x)**

Returns an implementation-dependent approximation to the natural logarithm of  $x$ .

If  $x$  is NaN, the result is NaN.

If  $x$  is less than 0, the result is NaN.

If  $x$  is +0 or -0, the result is  $-\infty$ .

If  $x$  is 1, the result is +0.

If  $x$  is  $+\infty$ , the result is  $+\infty$ .

**15.8.2.11 max ( [ value1 [ , value2 [ , ... ] ] ] )**

Given zero or more arguments, calls ToNumber on each of the arguments and returns the largest of the resulting values.

If no arguments are given, the result is  $-\infty$ .

If any value is NaN, the result is NaN.

The comparison of values to determine the largest value is done as in 11.8.5 except that +0 is considered to be larger than -0.

The **length** property of the **max** method is 2.

**15.8.2.12 min ( [ value1 [ , value2 [ , ... ] ] ] )**

Given zero or more arguments, calls ToNumber on each of the arguments and returns the smallest of the resulting values.

If no arguments are given, the result is  $+\infty$ .

If any value is NaN, the result is NaN.

The comparison of values to determine the smallest value is done as in 11.8.5 except that +0 is considered to be larger than -0.

The **length** property of the **min** method is 2.

**15.8.2.13 pow (x, y)**

Returns an implementation-dependent approximation to the result of raising  $x$  to the power  $y$ .

If  $y$  is NaN, the result is NaN.

If  $y$  is +0, the result is 1, even if  $x$  is NaN.

If  $y$  is -0, the result is 1, even if  $x$  is NaN.

If  $x$  is NaN and  $y$  is nonzero, the result is NaN.

If  $\text{abs}(x) > 1$  and  $y$  is  $+\infty$ , the result is  $+\infty$ .

If  $\text{abs}(x) > 1$  and  $y$  is  $-\infty$ , the result is +0.

If  $\text{abs}(x) = 1$  and  $y$  is  $+\infty$ , the result is NaN.

If  $\text{abs}(x) = 1$  and  $y$  is  $-\infty$ , the result is NaN.

If  $\text{abs}(x) < 1$  and  $y$  is  $+\infty$ , the result is +0.

If  $\text{abs}(x) < 1$  and  $y$  is  $-\infty$ , the result is  $+\infty$ .

If  $x$  is  $+\infty$  and  $y > 0$ , the result is  $+\infty$ .

If  $x$  is  $+\infty$  and  $y < 0$ , the result is +0.

If  $x$  is  $-\infty$  and  $y > 0$  and  $y$  is an odd integer, the result is  $-\infty$ .

If  $x$  is  $-\infty$  and  $y > 0$  and  $y$  is not an odd integer, the result is  $+\infty$ .

If  $x$  is  $-\infty$  and  $y < 0$  and  $y$  is an odd integer, the result is -0.

If  $x$  is  $-\infty$  and  $y < 0$  and  $y$  is not an odd integer, the result is +0.

If  $x$  is +0 and  $y > 0$ , the result is +0.

If  $x$  is +0 and  $y < 0$ , the result is  $+\infty$ .

If  $x$  is -0 and  $y > 0$  and  $y$  is an odd integer, the result is -0.

If  $x$  is -0 and  $y > 0$  and  $y$  is not an odd integer, the result is +0.

If  $x$  is  $-0$  and  $y < 0$  and  $y$  is an odd integer, the result is  $-\infty$ .  
If  $x$  is  $-0$  and  $y < 0$  and  $y$  is not an odd integer, the result is  $+\infty$ .  
If  $x < 0$  and  $x$  is finite and  $y$  is finite and  $y$  is not an integer, the result is NaN.

**15.8.2.14 random ( )**

Returns a number value with positive sign, greater than or equal to 0 but less than 1, chosen randomly or pseudo randomly with approximately uniform distribution over that range, using an implementation-dependent algorithm or strategy. This function takes no arguments.

**15.8.2.15 round (x)**

Returns the number value that is closest to  $x$  and is equal to a mathematical integer. If two integer number values are equally close to  $x$ , then the result is the number value that is closer to  $+\infty$ . If  $x$  is already an integer, the result is  $x$ .

If  $x$  is NaN, the result is NaN.  
If  $x$  is  $+0$ , the result is  $+0$ .  
If  $x$  is  $-0$ , the result is  $-0$ .  
If  $x$  is  $+\infty$ , the result is  $+\infty$ .  
If  $x$  is  $-\infty$ , the result is  $-\infty$ .  
If  $x$  is greater than 0 but less than 0.5, the result is  $+0$ .  
If  $x$  is less than 0 but greater than or equal to  $-0.5$ , the result is  $-0$ .

*NOTE 1*

*Math.round(3.5) returns 4, but Math.round(-3.5) returns -3.*

*NOTE 2*

*The value of **Math.round(x)** is the same as the value of **Math.floor(x+0.5)**, except when  $x$  is  $-0$  or is less than 0 but greater than or equal to  $-0.5$ ; for these cases **Math.round(x)** returns  $-0$ , but **Math.floor(x+0.5)** returns  $+0$ .*

**15.8.2.16 sin (x)**

Returns an implementation-dependent approximation to the sine of  $x$ . The argument is expressed in radians.

If  $x$  is NaN, the result is NaN.  
If  $x$  is  $+0$ , the result is  $+0$ .  
If  $x$  is  $-0$ , the result is  $-0$ .  
If  $x$  is  $+\infty$  or  $-\infty$ , the result is NaN.

**15.8.2.17 sqrt (x)**

Returns an implementation-dependent approximation to the square root of  $x$ .

If  $x$  is NaN, the result is NaN.  
If  $x$  less than 0, the result is NaN.  
If  $x$  is  $+0$ , the result is  $+0$ .  
If  $x$  is  $-0$ , the result is  $-0$ .  
If  $x$  is  $+\infty$ , the result is  $+\infty$ .

**15.8.2.18 tan (x)**

Returns an implementation-dependent approximation to the tangent of  $x$ . The argument is expressed in radians.

If  $x$  is NaN, the result is NaN.  
If  $x$  is  $+0$ , the result is  $+0$ .  
If  $x$  is  $-0$ , the result is  $-0$ .  
If  $x$  is  $+\infty$  or  $-\infty$ , the result is NaN.

## 15.9 Date Objects

### 15.9.1 Overview of Date Objects and Definitions of Internal Operators

A Date object contains a number indicating a particular instant in time to within a millisecond. The number may also be **NaN**, indicating that the Date object does not represent a specific instant of time.

The following sections define a number of functions for operating on time values. Note that, in every case, if any argument to such a function is **NaN**, the result will be **NaN**.

#### 15.9.1.1 Time Range

Time is measured in ECMAScript in milliseconds since 01 January, 1970 UTC. Leap seconds are ignored. It is assumed that there are exactly 86,400,000 milliseconds per day. ECMAScript number values can represent all integers from  $-9,007,199,254,740,991$  to  $9,007,199,254,740,991$ ; this range suffices to measure times to millisecond precision for any instant that is within approximately 285,616 years, either forward or backward, from 01 January, 1970 UTC.

The actual range of times supported by ECMAScript Date objects is slightly smaller: exactly  $-100,000,000$  days to  $100,000,000$  days measured relative to midnight at the beginning of 01 January, 1970 UTC. This gives a range of 8,640,000,000,000 milliseconds to either side of 01 January, 1970 UTC.

The exact moment of midnight at the beginning of 01 January, 1970 UTC is represented by the value **+0**.

#### 15.9.1.2 Day Number and Time within Day

A given time value  $t$  belongs to day number

$$\text{Day}(t) = \text{floor}(t / \text{msPerDay})$$

where the number of milliseconds per day is

$$\text{msPerDay} = 86400000$$

The remainder is called the time within the day:

$$\text{TimeWithinDay}(t) = t \text{ modulo } \text{msPerDay}$$

#### 15.9.1.3 Year Number

ECMAScript uses an extrapolated Gregorian system to map a day number to a year number and to determine the month and date within that year. In this system, leap years are precisely those which are (divisible by 4) and ((not divisible by 100) or (divisible by 400)). The number of days in year number  $y$  is therefore defined by

$$\begin{aligned} \text{DaysInYear}(y) &= 365 \text{ if } (y \text{ modulo } 4) \neq 0 \\ &= 366 \text{ if } (y \text{ modulo } 4) = 0 \text{ and } (y \text{ modulo } 100) \neq 0 \\ &= 365 \text{ if } (y \text{ modulo } 100) = 0 \text{ and } (y \text{ modulo } 400) \neq 0 \\ &= 366 \text{ if } (y \text{ modulo } 400) = 0 \end{aligned}$$

All non-leap years have 365 days with the usual number of days per month and leap years have an extra day in February. The day number of the first day of year  $y$  is given by:

$$\text{DayFromYear}(y) = 365 \times (y - 1970) + \text{floor}((y - 1969)/4) - \text{floor}((y - 1901)/100) + \text{floor}((y - 1601)/400)$$

The time value of the start of a year is:

$$\text{TimeFromYear}(y) = \text{msPerDay} \times \text{DayFromYear}(y)$$

A time value determines a year by:

$$\text{YearFromTime}(t) = \text{the largest integer } y \text{ (closest to positive infinity) such that } \text{TimeFromYear}(y) \leq t$$

The leap-year function is 1 for a time within a leap year and otherwise is zero:

$$\begin{aligned} \text{InLeapYear}(t) &= 0 \text{ if } \text{DaysInYear}(\text{YearFromTime}(t)) = 365 \\ &= 1 \text{ if } \text{DaysInYear}(\text{YearFromTime}(t)) = 366 \end{aligned}$$



### 15.9.1.4 Month Number

Months are identified by an integer in the range 0 to 11, inclusive. The mapping MonthFromTime(*t*) from a time value *t* to a month number is defined by:

MonthFromTime( <i>t</i> ) = 0	if	0	≤ DayWithinYear( <i>t</i> ) < 31
= 1	if	31	≤ DayWithinYear( <i>t</i> ) < 59+InLeapYear( <i>t</i> )
= 2	if	59+InLeapYear( <i>t</i> )	≤ DayWithinYear( <i>t</i> ) < 90+InLeapYear( <i>t</i> )
= 3	if	90+InLeapYear( <i>t</i> )	≤ DayWithinYear( <i>t</i> ) < 120+InLeapYear( <i>t</i> )
= 4	if	120+InLeapYear( <i>t</i> )	≤ DayWithinYear( <i>t</i> ) < 151+InLeapYear( <i>t</i> )
= 5	if	151+InLeapYear( <i>t</i> )	≤ DayWithinYear( <i>t</i> ) < 181+InLeapYear( <i>t</i> )
= 6	if	181+InLeapYear( <i>t</i> )	≤ DayWithinYear( <i>t</i> ) < 212+InLeapYear( <i>t</i> )
= 7	if	212+InLeapYear( <i>t</i> )	≤ DayWithinYear( <i>t</i> ) < 243+InLeapYear( <i>t</i> )
= 8	if	243+InLeapYear( <i>t</i> )	≤ DayWithinYear( <i>t</i> ) < 273+InLeapYear( <i>t</i> )
= 9	if	273+InLeapYear( <i>t</i> )	≤ DayWithinYear( <i>t</i> ) < 304+InLeapYear( <i>t</i> )
= 10	if	304+InLeapYear( <i>t</i> )	≤ DayWithinYear( <i>t</i> ) < 334+InLeapYear( <i>t</i> )
= 11	if	334+InLeapYear( <i>t</i> )	≤ DayWithinYear( <i>t</i> ) < 365+InLeapYear( <i>t</i> )

where

$$\text{DayWithinYear}(t) = \text{Day}(t) - \text{DayFromYear}(\text{YearFromTime}(t))$$

A month value of 0 specifies January; 1 specifies February; 2 specifies March; 3 specifies April; 4 specifies May; 5 specifies June; 6 specifies July; 7 specifies August; 8 specifies September; 9 specifies October; 10 specifies November; and 11 specifies December. Note that MonthFromTime(0) = 0, corresponding to Thursday, 01 January, 1970.

### 15.9.1.5 Date Number

A date number is identified by an integer in the range 1 through 31, inclusive. The mapping DateFromTime(*t*) from a time value *t* to a month number is defined by:

DateFromTime( <i>t</i> ) = DayWithinYear( <i>t</i> )+1	if MonthFromTime( <i>t</i> )=0
= DayWithinYear( <i>t</i> )-30	if MonthFromTime( <i>t</i> )=1
= DayWithinYear( <i>t</i> )-58-InLeapYear( <i>t</i> )	if MonthFromTime( <i>t</i> )=2
= DayWithinYear( <i>t</i> )-89-InLeapYear( <i>t</i> )	if MonthFromTime( <i>t</i> )=3
= DayWithinYear( <i>t</i> )-119-InLeapYear( <i>t</i> )	if MonthFromTime( <i>t</i> )=4
= DayWithinYear( <i>t</i> )-150-InLeapYear( <i>t</i> )	if MonthFromTime( <i>t</i> )=5
= DayWithinYear( <i>t</i> )-180-InLeapYear( <i>t</i> )	if MonthFromTime( <i>t</i> )=6
= DayWithinYear( <i>t</i> )-211-InLeapYear( <i>t</i> )	if MonthFromTime( <i>t</i> )=7
= DayWithinYear( <i>t</i> )-242-InLeapYear( <i>t</i> )	if MonthFromTime( <i>t</i> )=8
= DayWithinYear( <i>t</i> )-272-InLeapYear( <i>t</i> )	if MonthFromTime( <i>t</i> )=9
= DayWithinYear( <i>t</i> )-303-InLeapYear( <i>t</i> )	if MonthFromTime( <i>t</i> )=10
= DayWithinYear( <i>t</i> )-333-InLeapYear( <i>t</i> )	if MonthFromTime( <i>t</i> )=11

### 15.9.1.6 Week Day

The weekday for a particular time value *t* is defined as

$$\text{WeekDay}(t) = (\text{Day}(t) + 4) \text{ modulo } 7$$

A weekday value of 0 specifies Sunday; 1 specifies Monday; 2 specifies Tuesday; 3 specifies Wednesday; 4 specifies Thursday; 5 specifies Friday; and 6 specifies Saturday. Note that WeekDay(0) = 4, corresponding to Thursday, 01 January, 1970.

### 15.9.1.7 Local Time Zone Adjustment

An implementation of ECMAScript is expected to determine the local time zone adjustment. The local time zone adjustment is a value LocalTZA measured in milliseconds which when added to UTC represents the local *standard* time. Daylight saving time is *not* reflected by LocalTZA. [The value LocalTZA does not vary with time but depends only on the geographic location.]

### 15.9.1.8 Daylight Saving Time Adjustment

An implementation of ECMAScript is expected to determine the daylight saving time algorithm. The algorithm to determine the daylight saving time adjustment DaylightSavingTA(*t*), measured in milliseconds, must depend only on four things:

pratapL 7/2/2008 2:05 PM  
Deleted: 8

pratapL 7/4/2008 10:07 AM  
Comment [53]: This assertion is incorrect. It assumes time zone boundaries are fixed for eternity. It is not, and is subject to politics (as seen by the recent DST change that has happened in US.

The wording in this section needs to change.

pratapL 7/2/2008 2:05 PM  
Deleted: 9

pratapL 7/4/2008 10:07 AM  
Comment [54]: Same as the earlier comment. This assertion about DST is incorrect. The wording needs to be changed.

(1) the time since the beginning of the year

$$t - \text{TimeFromYear}(\text{YearFromTime}(t))$$

(2) whether  $t$  is in a leap year

$$\text{InLeapYear}(t)$$

(3) the week day of the beginning of the year

$$\text{WeekDay}(\text{TimeFromYear}(\text{YearFromTime}(t)))$$

and (4) the geographic location.

The implementation of ECMAScript should not try to determine whether the exact time was subject to daylight saving time, but just whether daylight saving time would have been in effect if the current daylight saving time algorithm had been used at the time. This avoids complications such as taking into account the years that the locale observed daylight saving time year round.

If the host environment provides functionality for determining daylight saving time, the implementation of ECMAScript is free to map the year in question to an equivalent year (same leap-year-ness and same starting week day for the year) for which the host environment provides daylight saving time information. The only restriction is that all equivalent years should produce the same result.

#### 15.9.1.9 Local Time

Conversion from UTC to local time is defined by

$$\text{LocalTime}(t) = t + \text{LocalTZA} + \text{DaylightSavingTA}(t)$$

Conversion from local time to UTC is defined by

$$\text{UTC}(t) = t - \text{LocalTZA} - \text{DaylightSavingTA}(t - \text{LocalTZA})$$

Note that  $\text{UTC}(\text{LocalTime}(t))$  is not necessarily always equal to  $t$ .

#### 15.9.1.10 Hours, Minutes, Second, and Milliseconds

The following functions are useful in decomposing time values:

$$\text{HourFromTime}(t) = \text{floor}(t / \text{msPerHour}) \text{ modulo } \text{HoursPerDay}$$

$$\text{MinFromTime}(t) = \text{floor}(t / \text{msPerMinute}) \text{ modulo } \text{MinutesPerHour}$$

$$\text{SecFromTime}(t) = \text{floor}(t / \text{msPerSecond}) \text{ modulo } \text{SecondsPerMinute}$$

$$\text{msFromTime}(t) = t \text{ modulo } \text{msPerSecond}$$

where

$$\text{HoursPerDay} = 24$$

$$\text{MinutesPerHour} = 60$$

$$\text{SecondsPerMinute} = 60$$

$$\text{msPerSecond} = 1000$$

$$\text{msPerMinute} = \text{msPerSecond} \times \text{SecondsPerMinute} = 60000$$

$$\text{msPerHour} = \text{msPerMinute} \times \text{MinutesPerHour} = 3600000$$

#### 15.9.1.11 MakeTime (hour, min, sec, ms)

The operator `MakeTime` calculates a number of milliseconds from its four arguments, which must be ECMAScript number values. This operator functions as follows:

1. If *hour* is not finite or *min* is not finite or *sec* is not finite or *ms* is not finite, return **NaN**.
2. Call `ToInteger(hour)`.
3. Call `ToInteger(min)`.
4. Call `ToInteger(sec)`.
5. Call `ToInteger(ms)`.

6. Compute  $\text{Result}(2) * \text{msPerHour} + \text{Result}(3) * \text{msPerMinute} + \text{Result}(4) * \text{msPerSecond} + \text{Result}(5)$ , performing the arithmetic according to IEEE 754 rules (that is, as if using the ECMAScript operators  $*$  and  $+$ ).
7. Return  $\text{Result}(6)$ .

#### 15.9.1.12 MakeDay (year, month, date)

The operator `MakeDay` calculates a number of days from its three arguments, which must be ECMAScript number values. This operator functions as follows:

1. If *year* is not finite or *month* is not finite or *date* is not finite, return **NaN**.
2. Call `ToInteger(year)`.
3. Call `ToInteger(month)`.
4. Call `ToInteger(date)`.
5. Compute  $\text{Result}(2) + \text{floor}(\text{Result}(3)/12)$ .
6. Compute  $\text{Result}(3) \bmod 12$ .
7. Find a value *t* such that  $\text{YearFromTime}(t) == \text{Result}(5)$  and  $\text{MonthFromTime}(t) == \text{Result}(6)$  and  $\text{DateFromTime}(t) == 1$ ; but if this is not possible (because some argument is out of range), return **NaN**.
8. Compute  $\text{Day}(\text{Result}(7)) + \text{Result}(4) - 1$ .
9. Return  $\text{Result}(8)$ .

#### 15.9.1.13 MakeDate (day, time)

The operator `MakeDate` calculates a number of milliseconds from its two arguments, which must be ECMAScript number values. This operator functions as follows:

1. If *day* is not finite or *time* is not finite, return **NaN**.
2. Compute  $\text{day} * \text{msPerDay} + \text{time}$ .
3. Return  $\text{Result}(2)$ .

#### 15.9.1.14 TimeClip (time)

The operator `TimeClip` calculates a number of milliseconds from its argument, which must be an ECMAScript number value. This operator functions as follows:

1. If *time* is not finite, return **NaN**.
2. If  $\text{abs}(\text{Result}(1)) > 8.64 \times 10^{15}$ , return **NaN**.
3. Return an implementation-dependent choice of either `ToInteger(Result(2))` or `ToInteger(Result(2)) + (+0)`.  
(Adding a positive zero converts  $-0$  to  $+0$ .)

#### NOTE

The point of step 3 is that an implementation is permitted a choice of internal representations of time values, for example as a 64-bit signed integer or as a 64-bit floating-point value. Depending on the implementation, this internal representation may or may not distinguish  $-0$  and  $+0$ .

#### 15.9.1.15 Date Time string format

The Simplified ISO 8601 format is as follows: **YYYY-MM-DDTHH:mm:ss.sssTZ**

Where the fields are as follows:

**YYYY** is the year in the Gregorian calendar

**MM** is the month of the year between 01 (January) and 12 (December)

**DD** is the day of the month between 01 and 31.

The "T" appears literally in the string, to indicate the beginning of the time element, as specified in ISO 8601.

**HH** is the number of complete hours that have passed since midnight

**mm** is the number of complete minutes since the start of the hour

**ss** is the number of complete seconds since the start of the minute

The '.' (dot)

[sss](#) is the number of complete milliseconds since the start of the second.

Both the ‘.’ And the milliseconds field are optional

[TZ](#) is the timezone specified as [Z](#) (for UTC) or either [+](#) or [-](#) followed by a time expression  
[HH:MM](#)

#### Extended years

ECMAScript requires the ability to specify 6 digit years (extended years); approximately 285,616 years, either forward or backward, from 01 January, 1970 UTC. To represent years before 0 or after 9999, ISO 8601 permits the expansion of the year representation, but only by prior agreement between the sender and the receiver. In the simplified ECMAScript format such an expanded year representation shall have 2 extra year digits and is always prefixed with a [+](#) or [-](#) sign with the convention that year 0 is positive.

#### NOTE

This format includes date-only forms:

[YYYY](#)  
[YYYY-MM](#)  
[YYYY-MM-DD](#)

Time-only forms with an optional time zone appended:

[THH:mm](#)  
[THH:mm:ss](#)  
[THH:mm:ss.sss](#)

It also includes “date-times” which could be any combination of the above.

All numbers must be base 10.

Illegal values (out-of-bounds as well as syntax errors) in a format string means that the format string is not a valid instance of this format.

As every day both starts and ends with midnight, the two notations [00:00](#) and [24:00](#) are available to distinguish the two midnights that can be associated with one date. This means that the following two notations refer to exactly the same point in time: [1995-02-04T24:00](#) and [1995-02-05T00:00](#)

There exists no international standard that specifies abbreviations for civil time zones like CET, EST, etc. and sometimes the same abbreviation is even used for two very different time zones. For this reason, ISO 8601 and this format specifies *numeric* representations of date and time.

### 15.9.2 The Date Constructor Called as a Function

When **Date** is called as a function rather than as a constructor, it returns a string representing the current time (UTC).

#### *NOTE*

*The function call **Date (...)** is not equivalent to the object creation expression **new Date (...)** with the same arguments.*

#### 15.9.2.1 **Date ( [ year [, month [, date [, hours [, minutes [, seconds [, ms ] ] ] ] ] ] ] )**

All of the arguments are optional; any arguments supplied are accepted but are completely ignored. A string is created and returned as if by the expression **(new Date()).toString()** where **Date** is the standard built-in constructor with that name and **toString** is the standard built-in method **Date.prototype.toString**.

### 15.9.3 The Date Constructor

When **Date** is called as part of a **new** expression, it is a constructor: it initialises the newly created object.

### 15.9.3.1 new Date (year, month [, date [, hours [, minutes [, seconds [, ms ] ] ] ] ] )

When **Date** is called with two to seven arguments, it computes the date from *year*, *month*, and (optionally) *date*, *hours*, *minutes*, *seconds* and *ms*.

The `[[Prototype]]` property of the newly constructed object is set to the original Date prototype object, the one that is the initial value of **Date.prototype** (15.9.4.1).

The `[[Class]]` property of the newly constructed object is set to **"Date"**.

[The `\[\[Extensible\]\]` property of the newly constructed object is set to \*\*true\*\*.](#)

The `[[PrimitiveValue]]` property of the newly constructed object is set as follows:

1. Call `ToNumber(year)`.
2. Call `ToNumber(month)`.
3. If *date* is supplied use `ToNumber(date)`; else use **1**.
4. If *hours* is supplied use `ToNumber(hours)`; else use **0**.
5. If *minutes* is supplied use `ToNumber(minutes)`; else use **0**.
6. If *seconds* is supplied use `ToNumber(seconds)`; else use **0**.
7. If *ms* is supplied use `ToNumber(ms)`; else use **0**.
8. If `Result(1)` is not **NaN** and  $0 \leq \text{ToInteger}(\text{Result}(1)) \leq 99$ , `Result(8)` is  $1900 + \text{ToInteger}(\text{Result}(1))$ ; otherwise, `Result(8)` is `Result(1)`.
9. Compute `MakeDay(Result(8), Result(2), Result(3))`.
10. Compute `MakeTime(Result(4), Result(5), Result(6), Result(7))`.
11. Compute `MakeDate(Result(9), Result(10))`.
12. Set the `[[PrimitiveValue]]` property of the newly constructed object to `TimeClip(UTC(Result(11)))`.

### 15.9.3.2 new Date (value)

The `[[Prototype]]` property of the newly constructed object is set to the original Date prototype object, the one that is the initial value of **Date.prototype** (15.9.4.1).

The `[[Class]]` property of the newly constructed object is set to **"Date"**.

[The `\[\[Extensible\]\]` property of the newly constructed object is set to \*\*true\*\*.](#)

The `[[PrimitiveValue]]` property of the newly constructed object is set as follows:

1. Call `ToPrimitive(value)`.
2. If `Type(Result(1))` is `String`, then go to step 5.
3. Let *V* be `ToNumber(Result(1))`.
4. Set the `[[PrimitiveValue]]` property of the newly constructed object to `TimeClip(V)` and return.
5. Parse `Result(1)` as a date, in exactly the same manner as for the **parse** method (15.9.4.2); let *V* be the time value for this date.
6. Go to step 4.

### 15.9.3.3 new Date ( )

The `[[Prototype]]` property of the newly constructed object is set to the original Date prototype object, the one that is the initial value of **Date.prototype** (15.9.4.1).

The `[[Class]]` property of the newly constructed object is set to **"Date"**.

[The `\[\[Extensible\]\]` property of the newly constructed object is set to \*\*true\*\*.](#)

The `[[PrimitiveValue]]` property of the newly constructed object is set to the current time (UTC).

## 15.9.4 Properties of the Date Constructor

The value of the internal `[[Prototype]]` property of the Date constructor is the Function prototype object (15.3.4).

Besides the internal properties and the **length** property (whose value is 7), the Date constructor has the following properties:

#### 15.9.4.1 Date.prototype

The initial value of `Date.prototype` is the built-in Date prototype object (15.9.5).

This property has the attributes { `[[Writable]]: false`, `[[Enumerable]]: false`, `[[Flexible]]: false` }.

#### 15.9.4.2 Date.parse (string)

The `parse` function applies the `ToString` operator to its argument and interprets the resulting string as a date; it returns a number, the UTC time value corresponding to the date. The string may be interpreted as a local time, a UTC time, or a time in some other time zone, depending on the contents of the string. [The function first attempts to parse the format of the string according to the rules called out in Date Time String Sormat \(15.9.1.15\). If the string does not conform to that format the function may fall back to any implementation-specific heuristics or implementation-specific date formats. Unrecognizable strings or dates containing illegal element values in the format string shall cause Date.parse to return NaN.](#)

If `x` is any Date object whose milliseconds amount is zero within a particular implementation of ECMAScript, then all of the following expressions should produce the same numeric value in that implementation, if all the properties referenced have their initial values:

`x.valueOf()`

`Date.parse(x.toString())`

`Date.parse(x.toUTCString())`

However, the expression

`Date.parse(x.toLocaleString())`

is not required to produce the same number value as the preceding three expressions and, in general, the value produced by `Date.parse` is implementation-dependent when given any string value that could not be produced in that implementation by the `toString` or `toUTCString` method.

#### 15.9.4.3 Date.UTC (year, month [, date [, hours [, minutes [, seconds [, ms ] ] ] ] ] )

When the `UTC` function is called with fewer than two arguments, the behaviour is implementation-dependent. When the `UTC` function is called with two to seven arguments, it computes the date from `year`, `month` and (optionally) `date`, `hours`, `minutes`, `seconds` and `ms`. The following steps are taken:

1. Call `ToNumber(year)`.
2. Call `ToNumber(month)`.
3. If `date` is supplied use `ToNumber(date)`; else use `1`.
4. If `hours` is supplied use `ToNumber(hours)`; else use `0`.
5. If `minutes` is supplied use `ToNumber(minutes)`; else use `0`.
6. If `seconds` is supplied use `ToNumber(seconds)`; else use `0`.
7. If `ms` is supplied use `ToNumber(ms)`; else use `0`.
8. If `Result(1)` is not `NaN` and  $0 \leq \text{ToInteger}(\text{Result}(1)) \leq 99$ , `Result(8)` is  $1900 + \text{ToInteger}(\text{Result}(1))$ ; otherwise, `Result(8)` is `Result(1)`.
9. Compute `MakeDay(Result(8), Result(2), Result(3))`.
10. Compute `MakeTime(Result(4), Result(5), Result(6), Result(7))`.
11. Return `TimeClip(MakeDate(Result(9), Result(10)))`.

The `length` property of the `UTC` function is `7`.

#### NOTE

*The UTC function differs from the Date constructor in two ways: it returns a time value as a number, rather than creating a Date object, and it interprets the arguments in UTC rather than as local time.*

#### 15.9.5 Properties of the Date Prototype Object

The Date prototype object is itself a Date object (its `[[Class]]` is `"Date"`) whose value is `NaN`.

The value of the internal `[[Prototype]]` property of the Date prototype object is the Object prototype object (15.2.3.1).

pratapL\_5/29/2008 12:39 AM

Deleted: DontEnum, DontDelete, ReadOnly

In following descriptions of functions that are properties of the Date prototype object, the phrase “this Date object” refers to the object that is the **this** value for the invocation of the function. None of these functions are generic; a **TypeError** exception is thrown if the **this** value is not an object for which the value of the internal `[[Class]]` property is **"Date"**. Also, the phrase “this time value” refers to the number value for the time represented by this Date object, that is, the value of the internal `[[PrimitiveValue]]` property of this Date object.

**15.9.5.1 Date.prototype.constructor**

The initial value of `Date.prototype.constructor` is the built-in **Date** constructor.

**15.9.5.2 Date.prototype.toString ( )**

This function returns a string value. The contents of the string are implementation-dependent, but are intended to represent the Date in the current time zone in a convenient, human-readable form.

*NOTE* For any Date value `d` whose milliseconds amount is zero, the result of `Date.parse(d.toString())` is equal to `d.valueOf()`. See section 15.9.4.2.

**15.9.5.3 Date.prototype.toDateString ( )**

This function returns a string value. The contents of the string are implementation-dependent, but are intended to represent the “date” portion of the Date in the current time zone in a convenient, human-readable form.

**15.9.5.4 Date.prototype.toTimeString ( )**

This function returns a string value. The contents of the string are implementation-dependent, but are intended to represent the “time” portion of the Date in the current time zone in a convenient, human-readable form.

**15.9.5.5 Date.prototype.toLocaleString ( )**

This function returns a string value. The contents of the string are implementation-dependent, but are intended to represent the Date in the current time zone in a convenient, human-readable form that corresponds to the conventions of the host environment’s current locale.

*NOTE*

*The first parameter to this function is likely to be used in a future version of this standard; it is recommended that implementations do not use this parameter position for anything else.*

**15.9.5.6 Date.prototype.toLocaleDateString ( )**

This function returns a string value. The contents of the string are implementation-dependent, but are intended to represent the “date” portion of the Date in the current time zone in a convenient, human-readable form that corresponds to the conventions of the host environment’s current locale.

*NOTE*

*The first parameter to this function is likely to be used in a future version of this standard; it is recommended that implementations do not use this parameter position for anything else.*

**15.9.5.7 Date.prototype.toLocaleTimeString ( )**

This function returns a string value. The contents of the string are implementation-dependent, but are intended to represent the “time” portion of the Date in the current time zone in a convenient, human-readable form that corresponds to the conventions of the host environment’s current locale.

*NOTE*

*The first parameter to this function is likely to be used in a future version of this standard; it is recommended that implementations do not use this parameter position for anything else.*

**15.9.5.8 Date.prototype.valueOf ( )**

The `valueOf` function returns a number, which is this time value.

**15.9.5.9 Date.prototype.getTime ( )**

1. If the **this** value is not an object whose `[[Class]]` property is **"Date"**, throw a **TypeError** exception.
2. Return this time value.

pratapL 3/25/2008 1:22 AM  
Deleted: NOTE - ... [23]

**15.9.5.10 Date.prototype.getFullYear ( )**

1. Let *t* be this time value.
2. If *t* is NaN, return NaN.
3. Return YearFromTime(LocalTime(*t*)).

**15.9.5.11 Date.prototype.getUTCFullYear ( )**

1. Let *t* be this time value.
2. If *t* is NaN, return NaN.
3. Return YearFromTime(*t*).

**15.9.5.12 Date.prototype.getMonth ( )**

1. Let *t* be this time value.
2. If *t* is NaN, return NaN.
3. Return MonthFromTime(LocalTime(*t*)).

**15.9.5.13 Date.prototype.getUTCMonth ( )**

1. Let *t* be this time value.
2. If *t* is NaN, return NaN.
3. Return MonthFromTime(*t*).

**15.9.5.14 Date.prototype.getDate ( )**

1. Let *t* be this time value.
2. If *t* is NaN, return NaN.
3. Return DateFromTime(LocalTime(*t*)).

**15.9.5.15 Date.prototype.getUTCDate ( )**

1. Let *t* be this time value.
2. If *t* is NaN, return NaN.
3. Return DateFromTime(*t*).

**15.9.5.16 Date.prototype.getDay ( )**

1. Let *t* be this time value.
2. If *t* is NaN, return NaN.
3. Return WeekDay(LocalTime(*t*)).

**15.9.5.17 Date.prototype.getUTCDay ( )**

1. Let *t* be this time value.
2. If *t* is NaN, return NaN.
3. Return WeekDay(*t*).

**15.9.5.18 Date.prototype.getHours ( )**

1. Let *t* be this time value.
2. If *t* is NaN, return NaN.
3. Return HourFromTime(LocalTime(*t*)).

**15.9.5.19 Date.prototype.getUTCHours ( )**

1. Let *t* be this time value.
2. If *t* is NaN, return NaN.
3. Return HourFromTime(*t*).

**15.9.5.20 Date.prototype.getMinutes ( )**

1. Let *t* be this time value.
2. If *t* is NaN, return NaN.
3. Return MinFromTime(LocalTime(*t*)).



**15.9.5.21 Date.prototype.getUTCMinutes ( )**

1. Let *t* be this time value.
2. If *t* is **NaN**, return **NaN**.
3. Return `MinFromTime(t)`.

**15.9.5.22 Date.prototype.getSeconds ( )**

1. Let *t* be this time value.
2. If *t* is **NaN**, return **NaN**.
3. Return `SecFromTime(LocalTime(t))`.

**15.9.5.23 Date.prototype.getUTCSeconds ( )**

1. Let *t* be this time value.
2. If *t* is **NaN**, return **NaN**.
3. Return `SecFromTime(t)`.

**15.9.5.24 Date.prototype.getMilliseconds ( )**

1. Let *t* be this time value.
2. If *t* is **NaN**, return **NaN**.
3. Return `msFromTime(LocalTime(t))`.

**15.9.5.25 Date.prototype.getUTCMilliseconds ( )**

1. Let *t* be this time value.
2. If *t* is **NaN**, return **NaN**.
3. Return `msFromTime(t)`.

**15.9.5.26 Date.prototype.getTimezoneOffset ( )**

Returns the difference between local time and UTC time in minutes.

1. Let *t* be this time value.
2. If *t* is **NaN**, return **NaN**.
3. Return  $(t - \text{LocalTime}(t)) / \text{msPerMinute}$ .

**15.9.5.27 Date.prototype.setTime (time)**

1. If the **this** value is not a Date object, throw a **TypeError** exception.
2. Call `ToNumber(time)`.
3. Call `TimeClip(Result(1))`.
4. Set the `[[PrimitiveValue]]` property of the **this** value to `Result(2)`.
5. Return the value of the `[[PrimitiveValue]]` property of the **this** value.

**15.9.5.28 Date.prototype.setMilliseconds (ms)**

1. Let *t* be the result of `LocalTime(this time value)`.
2. Call `ToNumber(ms)`.
3. Compute `MakeTime(HourFromTime(t), MinFromTime(t), SecFromTime(t), Result(2))`.
4. Compute `UTC(MakeDate(Day(t), Result(3)))`.
5. Set the `[[PrimitiveValue]]` property of the **this** value to `TimeClip(Result(4))`.
6. Return the value of the `[[PrimitiveValue]]` property of the **this** value.

**15.9.5.29 Date.prototype.setUTCMilliseconds (ms)**

1. Let *t* be this time value.
2. Call `ToNumber(ms)`.
3. Compute `MakeTime(HourFromTime(t), MinFromTime(t), SecFromTime(t), Result(2))`.
4. Compute `MakeDate(Day(t), Result(3))`.
5. Set the `[[PrimitiveValue]]` property of the **this** value to `TimeClip(Result(4))`.
6. Return the value of the `[[PrimitiveValue]]` property of the **this** value.

**15.9.5.30 Date.prototype.setSeconds (sec [, ms ] )**

If *ms* is not specified, this behaves as if *ms* were specified with the value `getMilliseconds( )`.

1. Let *t* be the result of `LocalTime(this time value)`.
2. Call `ToNumber(sec)`.
3. If *ms* is not specified, compute `msFromTime(t)`; otherwise, call `ToNumber(ms)`.
4. Compute `MakeTime(HourFromTime(t), MinFromTime(t), Result(2), Result(3))`.
5. Compute `UTC(MakeDate(Day(t), Result(4)))`.
6. Set the `[[PrimitiveValue]]` property of the **this** value to `TimeClip(Result(5))`.
7. Return the value of the `[[PrimitiveValue]]` property of the **this** value.

The **length** property of the **setSeconds** method is 2.

#### 15.9.5.31 **Date.prototype.setUTCSeconds (sec [, ms ] )**

If *ms* is not specified, this behaves as if *ms* were specified with the value `getUTCMilliseconds()`.

1. Let *t* be this time value.
2. Call `ToNumber(sec)`.
3. If *ms* is not specified, compute `msFromTime(t)`; otherwise, call `ToNumber(ms)`.
4. Compute `MakeTime(HourFromTime(t), MinFromTime(t), Result(2), Result(3))`.
5. Compute `MakeDate(Day(t), Result(4))`.
6. Set the `[[PrimitiveValue]]` property of the **this** value to `TimeClip(Result(5))`.
7. Return the value of the `[[PrimitiveValue]]` property of the **this** value.

The **length** property of the **setUTCSeconds** method is 2.

#### 15.9.5.33 **Date.prototype.setMinutes (min [, sec [, ms ] ] )**

If *sec* is not specified, this behaves as if *sec* were specified with the value `getSeconds()`.

If *ms* is not specified, this behaves as if *ms* were specified with the value `getMilliseconds()`.

1. Let *t* be the result of `LocalTime(this time value)`.
2. Call `ToNumber(min)`.
3. If *sec* is not specified, compute `SecFromTime(t)`; otherwise, call `ToNumber(sec)`.
4. If *ms* is not specified, compute `msFromTime(t)`; otherwise, call `ToNumber(ms)`.
5. Compute `MakeTime(HourFromTime(t), Result(2), Result(3), Result(4))`.
6. Compute `UTC(MakeDate(Day(t), Result(5)))`.
7. Set the `[[PrimitiveValue]]` property of the **this** value to `TimeClip(Result(6))`.
8. Return the value of the `[[PrimitiveValue]]` property of the **this** value.

The **length** property of the **setMinutes** method is 3.

#### 15.9.5.34 **Date.prototype.setUTCMinutes (min [, sec [, ms ] ] )**

If *sec* is not specified, this behaves as if *sec* were specified with the value `getUTCSeconds()`.

If *ms* is not specified, this behaves as if *ms* were specified with the value `getUTCMilliseconds()`.

1. Let *t* be this time value.
2. Call `ToNumber(min)`.
3. If *sec* is not specified, compute `SecFromTime(t)`; otherwise, call `ToNumber(sec)`.
4. If *ms* is not specified, compute `msFromTime(t)`; otherwise, call `ToNumber(ms)`.
5. Compute `MakeTime(HourFromTime(t), Result(2), Result(3), Result(4))`.
6. Compute `MakeDate(Day(t), Result(5))`.
7. Set the `[[PrimitiveValue]]` property of the **this** value to `TimeClip(Result(6))`.
8. Return the value of the `[[PrimitiveValue]]` property of the **this** value.

The **length** property of the **setUTCMinutes** method is 3.

#### 15.9.5.35 **Date.prototype.setHours (hour [, min [, sec [, ms ] ] ] )**

If *min* is not specified, this behaves as if *min* were specified with the value `getMinutes()`.

If *sec* is not specified, this behaves as if *sec* were specified with the value `getSeconds()`.

If *ms* is not specified, this behaves as if *ms* were specified with the value `getMilliseconds()`.

1. Let *t* be the result of `LocalTime(this time value)`.

2. Call `ToNumber(hour)`.
3. If `min` is not specified, compute `MinFromTime(t)`; otherwise, call `ToNumber(min)`.
4. If `sec` is not specified, compute `SecFromTime(t)`; otherwise, call `ToNumber(sec)`.
5. If `ms` is not specified, compute `msFromTime(t)`; otherwise, call `ToNumber(ms)`.
6. Compute `MakeTime(Result(2), Result(3), Result(4), Result(5))`.
7. Compute `UTC(MakeDate(Day(t), Result(6)))`.
8. Set the `[[PrimitiveValue]]` property of the `this` value to `TimeClip(Result(7))`.
9. Return the value of the `[[PrimitiveValue]]` property of the `this` value.

The `length` property of the `setHours` method is 4.

#### 15.9.5.36 `Date.prototype.setUTCHours (hour [, min [, sec [, ms ] ] ] )`

If `min` is not specified, this behaves as if `min` were specified with the value `getUTCMinutes( )`.

If `sec` is not specified, this behaves as if `sec` were specified with the value `getUTCSeconds( )`.

If `ms` is not specified, this behaves as if `ms` were specified with the value `getUTCMilliseconds( )`.

1. Let `t` be this time value.
2. Call `ToNumber(hour)`.
3. If `min` is not specified, compute `MinFromTime(t)`; otherwise, call `ToNumber(min)`.
4. If `sec` is not specified, compute `SecFromTime(t)`; otherwise, call `ToNumber(sec)`.
5. If `ms` is not specified, compute `msFromTime(t)`; otherwise, call `ToNumber(ms)`.
6. Compute `MakeTime(Result(2), Result(3), Result(4), Result(5))`.
7. Compute `MakeDate(Day(t), Result(6))`.
8. Set the `[[PrimitiveValue]]` property of the `this` value to `TimeClip(Result(7))`.
9. Return the value of the `[[PrimitiveValue]]` property of the `this` value.

The `length` property of the `setUTCHours` method is 4.

#### 15.9.5.36 `Date.prototype.setDate (date)`

1. Let `t` be the result of `LocalTime(this time value)`.
2. Call `ToNumber(date)`.
3. Compute `MakeDay(YearFromTime(t), MonthFromTime(t), Result(2))`.
4. Compute `UTC(MakeDate(Result(3), TimeWithinDay(t)))`.
5. Set the `[[PrimitiveValue]]` property of the `this` value to `TimeClip(Result(4))`.
6. Return the value of the `[[PrimitiveValue]]` property of the `this` value.

#### 15.9.5.37 `Date.prototype.setUTCDate (date)`

1. Let `t` be this time value.
2. Call `ToNumber(date)`.
3. Compute `MakeDay(YearFromTime(t), MonthFromTime(t), Result(2))`.
4. Compute `MakeDate(Result(3), TimeWithinDay(t))`.
5. Set the `[[PrimitiveValue]]` property of the `this` value to `TimeClip(Result(4))`.
6. Return the value of the `[[PrimitiveValue]]` property of the `this` value.

#### 15.9.5.38 `Date.prototype.setMonth (month [, date ] )`

If `date` is not specified, this behaves as if `date` were specified with the value `getDate( )`.

1. Let `t` be the result of `LocalTime(this time value)`.
2. Call `ToNumber(month)`.
3. If `date` is not specified, compute `DateFromTime(t)`; otherwise, call `ToNumber(date)`.
4. Compute `MakeDay(YearFromTime(t), Result(2), Result(3))`.
5. Compute `UTC(MakeDate(Result(4), TimeWithinDay(t)))`.
6. Set the `[[PrimitiveValue]]` property of the `this` value to `TimeClip(Result(5))`.
7. Return the value of the `[[PrimitiveValue]]` property of the `this` value.

The `length` property of the `setMonth` method is 2.

#### 15.9.5.39 `Date.prototype.setUTCMonth (month [, date ] )`

If `date` is not specified, this behaves as if `date` were specified with the value `getUTCDate( )`.

1. Let *t* be this time value.
2. Call `ToNumber(month)`.
3. If *date* is not specified, compute `DateFromTime(t)`; otherwise, call `ToNumber(date)`.
4. Compute `MakeDay(YearFromTime(t), Result(2), Result(3))`.
5. Compute `MakeDate(Result(4), TimeWithinDay(t))`.
6. Set the `[[PrimitiveValue]]` property of the **this** value to `TimeClip(Result(5))`.
7. Return the value of the `[[PrimitiveValue]]` property of the **this** value.

The `length` property of the `setUTCMonth` method is 2.

#### 15.9.5.40 `Date.prototype.setFullYear` (*year* [, *month* [, *date* ] ] )

If *month* is not specified, this behaves as if *month* were specified with the value `getMonth()`.

If *date* is not specified, this behaves as if *date* were specified with the value `getDate()`.

1. Let *t* be the result of `LocalTime(this time value)`; but if this time value is `NaN`, let *t* be `+0`.
2. Call `ToNumber(year)`.
3. If *month* is not specified, compute `MonthFromTime(t)`; otherwise, call `ToNumber(month)`.
4. If *date* is not specified, compute `DateFromTime(t)`; otherwise, call `ToNumber(date)`.
5. Compute `MakeDay(Result(2), Result(3), Result(4))`.
6. Compute `UTC(MakeDate(Result(5), TimeWithinDay(t)))`.
7. Set the `[[PrimitiveValue]]` property of the **this** value to `TimeClip(Result(6))`.
8. Return the value of the `[[PrimitiveValue]]` property of the **this** value.

The `length` property of the `setFullYear` method is 3.

#### 15.9.5.41 `Date.prototype.setUTCFullYear` (*year* [, *month* [, *date* ] ] )

If *month* is not specified, this behaves as if *month* were specified with the value `getUTCMonth()`.

If *date* is not specified, this behaves as if *date* were specified with the value `getUTCDate()`.

1. Let *t* be this time value; but if this time value is `NaN`, let *t* be `+0`.
2. Call `ToNumber(year)`.
3. If *month* is not specified, compute `MonthFromTime(t)`; otherwise, call `ToNumber(month)`.
4. If *date* is not specified, compute `DateFromTime(t)`; otherwise, call `ToNumber(date)`.
5. Compute `MakeDay(Result(2), Result(3), Result(4))`.
6. Compute `MakeDate(Result(5), TimeWithinDay(t))`.
7. Set the `[[PrimitiveValue]]` property of the **this** value to `TimeClip(Result(6))`.
8. Return the value of the `[[PrimitiveValue]]` property of the **this** value.

The `length` property of the `setUTCFullYear` method is 3.

#### 15.9.5.42 `Date.prototype.toUTCString` ( )

This function returns a string value. The contents of the string are implementation-dependent, but are intended to represent the Date in a convenient, human-readable form in UTC.

NOTE: the intent is produce string representation of a date that is more readable than the format specified in Section 15.9.1.15. It is not essential that the chosen format be unambiguous or easily machine parsable. If an implementation does not have a preferred human-readable format it is recommended to use the format called out in Section 15.9.1.15 but with a space rather than a “T” used to separate the date and time elements.

#### 15.9.5.43 `Date.prototype.toISOString` ( )

This function returns a string value. The format of the string is as called out in Date Time string format (15.9.1.15). All fields are present in the string. The time zone is always UTC, denoted by the suffix Z.

#### 15.9.5.44 `Date.prototype.toJSON`(*key*)

This function returns the same string as `Date.prototype.toISOString()`.

### 15.9.6 Properties of Date Instances

Date instances have no special properties beyond those inherited from the Date prototype object.

## 15.10 RegExp (Regular Expression) Objects

A RegExp object contains a regular expression and the associated flags.

### NOTE

The form and functionality of regular expressions is modelled after the regular expression facility in the Perl 5 programming language.

### 15.10.1 Patterns

The **RegExp** constructor applies the following grammar to the input pattern string. An error occurs if the grammar cannot interpret the string as an expansion of *Pattern*.

#### Syntax

*Pattern* ::

*Disjunction*

*Disjunction* ::

*Alternative*

*Alternative* | *Disjunction*

*Alternative* ::

[empty]

*Alternative Term*

*Term* ::

*Assertion*

*Atom*

*Atom Quantifier*

*Assertion* ::

**^**

**\$**

**\ b**

**\ B**

*Quantifier* ::

*QuantifierPrefix*

*QuantifierPrefix* ?

*QuantifierPrefix* ::

**\***

**+**

**?**

{ *DecimalDigits* }

{ *DecimalDigits* , }

{ *DecimalDigits* , *DecimalDigits* }

*Atom* ::

*PatternCharacter*

**.**

**\ AtomEscape**

*CharacterClass*

( *Disjunction* )

( ? : *Disjunction* )

( ? = *Disjunction* )

( ? ! *Disjunction* )

*PatternCharacter* :: *SourceCharacter* but not any of:

**^ \$ \ . \* + ? ( ) [ ] { } |**

*AtomEscape* ::  
    *DecimalEscape*  
    *CharacterEscape*  
    *CharacterClassEscape*

*CharacterEscape* ::  
    *ControlEscape*  
    **c** *ControlLetter*  
    *HexEscapeSequence*  
    *UnicodeEscapeSequence*  
    *IdentityEscape*

*ControlEscape* :: **one of**  
    **f n r t v**

*ControlLetter* :: **one of**  
    **a b c d e f g h i j k l m n o p q r s t u v w x y z**  
    **A B C D E F G H I J K L M N O P Q R S T U V W X Y Z**

*IdentityEscape* ::  
    *SourceCharacter* **but not IdentifierPart**

*DecimalEscape* ::  
    *DecimalIntegerLiteral* [lookahead  $\notin$  *DecimalDigit*]

*CharacterClassEscape* :: **one of**  
    **d D s S w W**

*CharacterClass* ::  
    [ [lookahead  $\notin$  {**^**}] *ClassRanges* ]  
    [ **^** *ClassRanges* ]

*ClassRanges* ::  
    [empty]  
    *NonemptyClassRanges*

*NonemptyClassRanges* ::  
    *ClassAtom*  
    *ClassAtom* *NonemptyClassRangesNoDash*  
    *ClassAtom* - *ClassAtom* *ClassRanges*

*NonemptyClassRangesNoDash* ::  
    *ClassAtom*  
    *ClassAtomNoDash* *NonemptyClassRangesNoDash*  
    *ClassAtomNoDash* - *ClassAtom* *ClassRanges*

*ClassAtom* ::  
    -  
    *ClassAtomNoDash*

*ClassAtomNoDash* ::  
    *SourceCharacter* **but not one of \ ] -**  
    \ *ClassEscape*

*ClassEscape* ::  
    *DecimalEscape*  
    **b**  
    *CharacterEscape*  
    *CharacterClassEscape*

## 15.10.2 Pattern Semantics

A regular expression pattern is converted into an internal function using the process described below. An implementation is encouraged to use more efficient algorithms than the ones listed below, as long as the results are the same.

### 15.10.2.1 Notation

The descriptions below use the following variables:

*Input* is the string being matched by the regular expression pattern. The notation *input*[*n*] means the *n*th character of *input*, where *n* can range between 0 (inclusive) and *InputLength* (exclusive).

*InputLength* is the number of characters in the *Input* string.

*NcapturingParens* is the total number of left capturing parentheses (i.e. the total number of times the *Atom* :: ( *Disjunction* ) production is expanded) in the pattern. A left capturing parenthesis is any ( pattern character that is matched by the ( terminal of the *Atom* :: ( *Disjunction* ) production.

*IgnoreCase* is the setting of the RegExp object's **ignoreCase** property.

*Multiline* is the setting of the RegExp object's **multiline** property.

Furthermore, the descriptions below use the following internal data structures:

A *CharSet* is a mathematical set of characters.

A *State* is an ordered pair (*endIndex*, *captures*) where *endIndex* is an integer and *captures* is an internal array of *NcapturingParens* values. States are used to represent partial match states in the regular expression matching algorithms. The *endIndex* is one plus the index of the last input character matched so far by the pattern, while *captures* holds the results of capturing parentheses. The *n*th element of *captures* is either a string that represents the value obtained by the *n*th set of capturing parentheses or **undefined** if the *n*th set of capturing parentheses hasn't been reached yet. Due to backtracking, many states may be in use at any time during the matching process.

A *MatchResult* is either a *State* or the special token **failure** that indicates that the match failed.

A *Continuation* function is an internal closure (i.e. an internal function with some arguments already bound to values) that takes one *State* argument and returns a *MatchResult* result. If an internal closure references variables bound in the function that creates the closure, the closure uses the values that these variables had at the time the closure was created. The continuation attempts to match the remaining portion (specified by the closure's already-bound arguments) of the pattern against the input string, starting at the intermediate state given by its *State* argument. If the match succeeds, the continuation returns the final *State* that it reached; if the match fails, the continuation returns **failure**.

A *Matcher* function is an internal closure that takes two arguments -- a *State* and a *Continuation* -- and returns a *MatchResult* result. The matcher attempts to match a middle subpattern (specified by the closure's already-bound arguments) of the pattern against the input string, starting at the intermediate state given by its *State* argument. The *Continuation* argument should be a closure that matches the rest of the pattern. After matching the subpattern of a pattern to obtain a new *State*, the matcher then calls *Continuation* on that state to test if the rest of the pattern can match as well. If it can, the matcher returns the state returned by the continuation; if not, the matcher may try different choices at its choice points, repeatedly calling *Continuation* until it either succeeds or all possibilities have been exhausted.

An *AssertionTester* function is an internal closure that takes a *State* argument and returns a boolean result. The assertion tester tests a specific condition (specified by the closure's already-bound arguments) against the current place in the input string and returns **true** if the condition matched or **false** if not.

An *EscapeValue* is either a character or an integer. An *EscapeValue* is used to denote the interpretation of a *DecimalEscape* escape sequence: a character *ch* means that the escape sequence is interpreted as the character *ch*, while an integer *n* means that the escape sequence is interpreted as a backreference to the *n*th set of capturing parentheses.

### 15.10.2.2 Pattern

The production *Pattern* :: *Disjunction* evaluates as follows:

1. Evaluate *Disjunction* to obtain a *Matcher* *m*.

2. Return an internal closure that takes two arguments, a string *str* and an integer *index*, and performs the following:
  1. Let *Input* be the given string *str*. This variable will be used throughout the functions in 15.10.2.
  2. Let *InputLength* be the length of *Input*. This variable will be used throughout the functions in 15.10.2.
  3. Let *c* be a Continuation that always returns its State argument as a successful MatchResult.
  4. Let *cap* be an internal array of *NcapturingParens* **undefined** values, indexed 1 through *NcapturingParens*.
  5. Let *x* be the State (*index*, *cap*).
  6. Call *m(x, c)* and return its result.

**Informative comments:** A *Pattern* evaluates ("compiles") to an internal function value. **RegExp.prototype.exec** can then apply this function to a string and an offset within the string to determine whether the pattern would match starting at exactly that offset within the string, and, if it does match, what the values of the capturing parentheses would be. The algorithms in 15.10.2 are designed so that compiling a pattern may throw a **SyntaxError** exception; on the other hand, once the pattern is successfully compiled, applying its result function to find a match in a string cannot throw an exception (except for any host-defined exceptions that can occur anywhere such as out-of-memory).

### 15.10.2.3 Disjunction

The production *Disjunction* :: *Alternative* evaluates by evaluating *Alternative* to obtain a Matcher and returning that Matcher.

The production *Disjunction* :: *Alternative* | *Disjunction* evaluates as follows:

1. Evaluate *Alternative* to obtain a Matcher *m1*.
2. Evaluate *Disjunction* to obtain a Matcher *m2*.
3. Return an internal Matcher closure that takes two arguments, a State *x* and a Continuation *c*, and performs the following:
  1. Call *m1(x, c)* and let *r* be its result.
  2. If *r* isn't **failure**, return *r*.
  3. Call *m2(x, c)* and return its result.

**Informative comments:** The | regular expression operator separates two alternatives. The pattern first tries to match the left *Alternative* (followed by the sequel of the regular expression); if it fails, it tries to match the right *Disjunction* (followed by the sequel of the regular expression). If the left *Alternative*, the right *Disjunction*, and the sequel all have choice points, all choices in the sequel are tried before moving on to the next choice in the left *Alternative*. If choices in the left *Alternative* are exhausted, the right *Disjunction* is tried instead of the left *Alternative*. Any capturing parentheses inside a portion of the pattern skipped by | produce **undefined** values instead of strings. Thus, for example,

```
/a|ab/.exec("abc")
```

returns the result "a" and not "ab". Moreover,

```
/((a)|(ab))((c)|(bc))/ .exec("abc")
```

returns the array

```
["abc", "a", "a", undefined, "bc", undefined, "bc"]
```

and not

```
["abc", "ab", undefined, "ab", "c", "c", undefined]
```

### 15.10.2.4 Alternative

The production *Alternative* :: [empty] evaluates by returning a Matcher that takes two arguments, a State *x* and a Continuation *c*, and returns the result of calling *c(x)*.

The production *Alternative* :: *Alternative Term* evaluates as follows:



1. Evaluate *Alternative* to obtain a Matcher *m1*.
2. Evaluate *Term* to obtain a Matcher *m2*.
3. Return an internal Matcher closure that takes two arguments, a State *x* and a Continuation *c*, and performs the following:
  1. Create a Continuation *d* that takes a State argument *y* and returns the result of calling *m2(y, c)*.
  2. Call *m1(x, d)* and return its result.

**Informative comments:** Consecutive *Terms* try to simultaneously match consecutive portions of the input string. If the left *Alternative*, the right *Term*, and the sequel of the regular expression all have choice points, all choices in the sequel are tried before moving on to the next choice in the right *Term*, and all choices in the right *Term* are tried before moving on to the next choice in the left *Alternative*.

#### 15.10.2.5 Term

The production *Term :: Assertion* evaluates by returning an internal Matcher closure that takes two arguments, a State *x* and a Continuation *c*, and performs the following:

1. Evaluate *Assertion* to obtain an AssertionTester *t*.
2. Call *t(x)* and let *r* be the resulting boolean value.
3. If *r* is **false**, return **failure**.
4. Call *c(x)* and return its result.

The production *Term :: Atom* evaluates by evaluating *Atom* to obtain a Matcher and returning that Matcher.

The production *Term :: Atom Quantifier* evaluates as follows:

1. Evaluate *Atom* to obtain a Matcher *m*.
2. Evaluate *Quantifier* to obtain the three results: an integer *min*, an integer (or  $\infty$ ) *max*, and boolean *greedy*.
3. If *max* is finite and less than *min*, then throw a **SyntaxError** exception.
4. Let *parenIndex* be the number of left capturing parentheses in the entire regular expression that occur to the left of this production expansion's *Term*. This is the total number of times the *Atom :: ( Disjunction )* production is expanded prior to this production's *Term* plus the total number of *Atom :: ( Disjunction )* productions enclosing this *Term*.
5. Let *parenCount* be the number of left capturing parentheses in the expansion of this production's *Atom*. This is the total number of *Atom :: ( Disjunction )* productions enclosed by this production's *Atom*.
6. Return an internal Matcher closure that takes two arguments, a State *x* and a Continuation *c*, and performs the following:
  1. Call *RepeatMatcher(m, min, max, greedy, x, c, parenIndex, parenCount)* and return its result.

The internal helper function *RepeatMatcher* takes eight parameters, a Matcher *m*, an integer *min*, an integer (or  $\infty$ ) *max*, a boolean *greedy*, a State *x*, a Continuation *c*, an integer *parenIndex*, and an integer *parenCount*, and performs the following:

1. If *max* is zero, then call *c(x)* and return its result.
2. Create an internal Continuation closure *d* that takes one State argument *y* and performs the following:

If *min* is zero and *y*'s *endIndex* is equal to *x*'s *endIndex*, then return **failure**.  
If *min* is zero then let *min2* be zero; otherwise let *min2* be *min*-1.  
If *max* is  $\infty$ , then let *max2* be  $\infty$ ; otherwise let *max2* be *max*-1.  
Call *RepeatMatcher(m, min2, max2, greedy, y, c, parenIndex, parenCount)* and return its result.
3. Let *cap* be a fresh copy of *x*'s *captures* internal array.
4. For every integer *k* that satisfies *parenIndex* < *k* and *k*  $\leq$  *parenIndex*+*parenCount*, set *cap[k]* to **undefined**.
5. Let *e* be *x*'s *endIndex*.
6. Let *xr* be the State (*e, cap*).
7. If *min* is not zero, then call *m(xr, d)* and return its result.
8. If *greedy* is **true**, then go to step 12.

9. Call  $c(x)$  and let  $z$  be its result.
10. If  $z$  is not **failure**, return  $z$ .
11. Call  $m(xr, d)$  and return its result.
12. Call  $m(xr, d)$  and let  $z$  be its result.
13. If  $z$  is not **failure**, return  $z$ .
14. Call  $c(x)$  and return its result.

**Informative comments:** An *Atom* followed by a *Quantifier* is repeated the number of times specified by the *Quantifier*. A quantifier can be non-greedy, in which case the *Atom* pattern is repeated as few times as possible while still matching the sequel, or it can be greedy, in which case the *Atom* pattern is repeated as many times as possible while still matching the sequel. The *Atom* pattern is repeated rather than the input string that it matches, so different repetitions of the *Atom* can match different input substrings.

If the *Atom* and the sequel of the regular expression all have choice points, the *Atom* is first matched as many (or as few, if non-greedy) times as possible. All choices in the sequel are tried before moving on to the next choice in the last repetition of *Atom*. All choices in the last ( $n^{\text{th}}$ ) repetition of *Atom* are tried before moving on to the next choice in the next-to-last ( $(n-1)^{\text{st}}$ ) repetition of *Atom*; at which point it may turn out that more or fewer repetitions of *Atom* are now possible; these are exhausted (again, starting with either as few or as many as possible) before moving on to the next choice in the ( $n-1$ )<sup>st</sup> repetition of *Atom* and so on.

Compare

```
/a[a-z]{2,4}/.exec("abcdefghi")
```

which returns "abcde" with

```
/a[a-z]{2,4}?/.exec("abcdefghi")
```

which returns "abc".

Consider also

```
/(aa|aabaac|ba|b|c)*/.exec("aabaac")
```

which, by the choice point ordering above, returns the array

```
["aaba", "ba"]
```

and not any of:

```
["aabaac", "aabaac"]
```

```
["aabaac", "c"]
```

The above ordering of choice points can be used to write a regular expression that calculates the greatest common divisor of two numbers (represented in unary notation). The following example calculates the gcd of 10 and 15:

```
"aaaaaaaaa,aaaaaaaaaaaaa".replace(/^(a+)\1*,\1+$/, "$1")
```

which returns the gcd in unary notation "aaaaa".

Step 4 of the *RepeatMatcher* clears *Atom*'s captures each time *Atom* is repeated. We can see its behaviour in the regular expression

```
/(z)((a+)?(b+)?(c))*/.exec("zacbbbcac")
```

which returns the array

```
["zacbbbcac", "z", "ac", "a", undefined, "c"]
```

and not

```
["zacbbbcac", "z", "ac", "a", "bbb", "c"]
```

because each iteration of the outermost  $*$  clears all captured strings contained in the quantified *Atom*, which in this case includes capture strings numbered 2, 3, and 4.

Step 1 of the *RepeatMatcher*'s closure *d* states that, once the minimum number of repetitions has been satisfied, any more expansions of *Atom* that match the empty string are not considered for further repetitions. This prevents the regular expression engine from falling into an infinite loop on patterns such as:

```
/(a*)*/.exec("b")
```

or the slightly more complicated:

```
/(a*)b\1+/.exec("baaaac")
```

which returns the array

```
["b", ""]
```

### 15.10.2.6 Assertion

The production *Assertion :: ^* evaluates by returning an internal *AssertionTester* closure that takes a *State* argument *x* and performs the following:

1. Let *e* be *x*'s *endIndex*.
2. If *e* is zero, return **true**.
3. If *Multiline* is **false**, return **false**.
4. If the character *Input[e-1]* is one of [LineTerminator](#), return **true**.
5. Return **false**.

The production *Assertion :: \$* evaluates by returning an internal *AssertionTester* closure that takes a *State* argument *x* and performs the following:

1. Let *e* be *x*'s *endIndex*.
2. If *e* is equal to *InputLength*, return **true**.
3. If *multiline* is **false**, return **false**.
4. If the character *Input[e]* is one of [LineTerminator](#), return **true**.
5. Return **false**.

The production *Assertion :: \ b* evaluates by returning an internal *AssertionTester* closure that takes a *State* argument *x* and performs the following:

1. Let *e* be *x*'s *endIndex*.
2. Call *IsWordChar(e-1)* and let *a* be the boolean result.
3. Call *IsWordChar(e)* and let *b* be the boolean result.
4. If *a* is **true** and *b* is **false**, return **true**.
5. If *a* is **false** and *b* is **true**, return **true**.
6. Return **false**.

The production *Assertion :: \ B* evaluates by returning an internal *AssertionTester* closure that takes a *State* argument *x* and performs the following:

1. Let *e* be *x*'s *endIndex*.
2. Call *IsWordChar(e-1)* and let *a* be the boolean result.
3. Call *IsWordChar(e)* and let *b* be the boolean result.
4. If *a* is **true** and *b* is **false**, return **false**.
5. If *a* is **false** and *b* is **true**, return **false**.
6. Return **true**.

The internal helper function *IsWordChar* takes an integer parameter *e* and performs the following:

1. If *e* == -1 or *e* == *InputLength*, return **false**.
2. Let *c* be the character *Input[e]*.
3. If *c* is one of the sixty-three characters in the table below, return **true**.

A	B	C	D	E	F	G	H	I	J	K	L	M	N	O	P	Q	R	S	T	U	V	W	X	Y	Z
A	B	C	D	E	F	G	H	I	J	K	L	M	N	O	P	Q	R	S	T	U	V	W	X	Y	Z

pratapL 7/2/2008 5:42 AM  
**Deleted:** the line terminator characters <LF>, <CR>, <LS>, or <PS>

pratapL 7/2/2008 5:43 AM  
**Deleted:** the line terminator characters <LF>, <CR>, <LS>, or <PS>

0 1 2 3 4 5 6 7 8 9 \_

4. Return **false**.

### 15.10.2.7 Quantifier

The production *Quantifier* :: *QuantifierPrefix* evaluates as follows:

1. Evaluate *QuantifierPrefix* to obtain the two results: an integer *min* and an integer (or  $\infty$ ) *max*.
2. Return the three results *min*, *max*, and **true**.

The production *Quantifier* :: *QuantifierPrefix* ? evaluates as follows:

1. Evaluate *QuantifierPrefix* to obtain the two results: an integer *min* and an integer (or  $\infty$ ) *max*.
2. Return the three results *min*, *max*, and **false**.

The production *QuantifierPrefix* :: \* evaluates by returning the two results 0 and  $\infty$ .

The production *QuantifierPrefix* :: + evaluates by returning the two results 1 and  $\infty$ .

The production *QuantifierPrefix* :: ? evaluates by returning the two results 0 and 1.

The production *QuantifierPrefix* :: { *DecimalDigits* } evaluates as follows:

1. Let *i* be the MV of *DecimalDigits* (see 7.8.3).
2. Return the two results *i* and *i*.

The production *QuantifierPrefix* :: { *DecimalDigits* , } evaluates as follows:

1. Let *i* be the MV of *DecimalDigits*.
2. Return the two results *i* and  $\infty$ .

The production *QuantifierPrefix* :: { *DecimalDigits* , *DecimalDigits* } evaluates as follows:

1. Let *i* be the MV of the first *DecimalDigits*.
2. Let *j* be the MV of the second *DecimalDigits*.
3. Return the two results *i* and *j*.

### 15.10.2.8 Atom

The production *Atom* :: *PatternCharacter* evaluates as follows:

1. Let *ch* be the character represented by *PatternCharacter*.
2. Let *A* be a one-element CharSet containing the character *ch*.
3. Call *CharacterSetMatcher*(*A*, **false**) and return its Matcher result.

The production *Atom* :: . evaluates as follows:

1. Let *A* be the set of all characters except [LineTerminator](#).
2. Call *CharacterSetMatcher*(*A*, **false**) and return its Matcher result.

The production *Atom* :: \ *AtomEscape* evaluates by evaluating *AtomEscape* to obtain a Matcher and returning that Matcher.

The production *Atom* :: *CharacterClass* evaluates as follows:

1. Evaluate *CharacterClass* to obtain a CharSet *A* and a boolean *invert*.
2. Call *CharacterSetMatcher*(*A*, *invert*) and return its Matcher result.

The production *Atom* :: ( *Disjunction* ) evaluates as follows:

1. Evaluate *Disjunction* to obtain a Matcher *m*.
2. Let *parenIndex* be the number of left capturing parentheses in the entire regular expression that occur to the left of this production expansion's initial left parenthesis. This is the total number of times the *Atom* :: ( *Disjunction* ) production is expanded prior to this production's *Atom* plus the total number of *Atom* :: ( *Disjunction* ) productions enclosing this *Atom*.

pratapL 7/2/2008 5:43 AM  
 Deleted: the four line terminator characters <LF>, <CR>, <LS>, or <PS>

3. Return an internal Matcher closure that takes two arguments, a State  $x$  and a Continuation  $c$ , and performs the following:
  1. Create an internal Continuation closure  $d$  that takes one State argument  $y$  and performs the following:
    - Let  $cap$  be a fresh copy of  $y$ 's *captures* internal array.
    - Let  $xe$  be  $x$ 's *endIndex*.
    - Let  $ye$  be  $y$ 's *endIndex*.
    - Let  $s$  be a fresh string whose characters are the characters of *Input* at positions  $xe$  (inclusive) through  $ye$  (exclusive).
    - Set  $cap[parenIndex+1]$  to  $s$ .
    - Let  $z$  be the State ( $ye, cap$ ).
    - Call  $c(z)$  and return its result.
  2. Call  $m(x, d)$  and return its result.

The production  $Atom :: ( ? : Disjunction )$  evaluates by evaluating  $Disjunction$  to obtain a Matcher and returning that Matcher.

The production  $Atom :: ( ? = Disjunction )$  evaluates as follows:

1. Evaluate  $Disjunction$  to obtain a Matcher  $m$ .
2. Return an internal Matcher closure that takes two arguments, a State  $x$  and a Continuation  $c$ , and performs the following:
  1. Let  $d$  be a Continuation that always returns its State argument as a successful MatchResult.
  2. Call  $m(x, d)$  and let  $r$  be its result.
  3. If  $r$  is **failure**, return **failure**.
  4. Let  $y$  be  $r$ 's State.
  5. Let  $cap$  be  $y$ 's *captures* internal array.
  6. Let  $xe$  be  $x$ 's *endIndex*.
  7. Let  $z$  be the State ( $xe, cap$ ).
  8. Call  $c(z)$  and return its result.

The production  $Atom :: ( ? ! Disjunction )$  evaluates as follows:

1. Evaluate  $Disjunction$  to obtain a Matcher  $m$ .
2. Return an internal Matcher closure that takes two arguments, a State  $x$  and a Continuation  $c$ , and performs the following:
  1. Let  $d$  be a Continuation that always returns its State argument as a successful MatchResult.
  2. Call  $m(x, d)$  and let  $r$  be its result.
  3. If  $r$  isn't **failure**, return **failure**.
  4. Call  $c(x)$  and return its result.

The internal helper function  $CharacterSetMatcher$  takes two arguments, a CharSet  $A$  and a boolean flag  $invert$ , and performs the following:

1. Return an internal Matcher closure that takes two arguments, a State  $x$  and a Continuation  $c$ , and performs the following:
  1. Let  $e$  be  $x$ 's *endIndex*.
  2. If  $e == InputLength$ , return **failure**.
  3. Let  $c$  be the character  $Input[e]$ .
  4. Let  $cc$  be the result of  $Canonicalize(c)$ .
  5. If  $invert$  is **true**, go to step 8.
  6. If there does not exist a member  $a$  of set  $A$  such that  $Canonicalize(a) == cc$ , then return **failure**.
  7. Go to step 9.
  8. If there exists a member  $a$  of set  $A$  such that  $Canonicalize(a) == cc$ , then return **failure**.
  9. Let  $cap$  be  $x$ 's *captures* internal array.
  10. Let  $y$  be the State ( $e+1, cap$ ).
  11. Call  $c(y)$  and return its result.

The internal helper function *Canonicalize* takes a character parameter *ch* and performs the following:

1. If *IgnoreCase* is **false**, return *ch*.
2. Let *u* be *ch* converted to upper case as if by calling [the standard built-in method `String.prototype.toUpperCase`](#) on the one-character string *ch*.
3. If *u* does not consist of a single character, return *ch*.
4. Let *cu* be *u*'s character.
5. If *ch*'s code point value is greater than or equal to decimal 128 and *cu*'s code point value is less than decimal 128, then return *ch*.
6. Return *cu*.

**Informative comments:** Parentheses of the form ( *Disjunction* ) serve both to group the components of the *Disjunction* pattern together and to save the result of the match. The result can be used either in a backreference ( \ followed by a nonzero decimal number), referenced in a replace string, or returned as part of an array from the regular expression matching function. To inhibit the capturing behaviour of parentheses, use the form (?: *Disjunction* ) instead.

The form (?: *Disjunction* ) specifies a zero-width positive lookahead. In order for it to succeed, the pattern inside *Disjunction* must match at the current position, but the current position is not advanced before matching the sequel. If *Disjunction* can match at the current position in several ways, only the first one is tried. Unlike other regular expression operators, there is no backtracking into a (?: form (this unusual behaviour is inherited from Perl). This only matters when the *Disjunction* contains capturing parentheses and the sequel of the pattern contains backreferences to those captures.

For example,

```
/(?=(a+))/ .exec("baaabac")
```

matches the empty string immediately after the first **b** and therefore returns the array:

```
["", "aaa"]
```

To illustrate the lack of backtracking into the lookahead, consider:

```
/(?=(a+))a*b\1/ .exec("baaabac")
```

This expression returns

```
["aba", "a"]
```

and not:

```
["aaaba", "a"]
```

The form (?! *Disjunction* ) specifies a zero-width negative lookahead. In order for it to succeed, the pattern inside *Disjunction* must fail to match at the current position. The current position is not advanced before matching the sequel. *Disjunction* can contain capturing parentheses, but backreferences to them only make sense from within *Disjunction* itself. Backreferences to these capturing parentheses from elsewhere in the pattern always return **undefined** because the negative lookahead must fail for the pattern to succeed. For example,

```
/(.*?)a(?!(a+)b\2c)\2(.*)/ .exec("baaabaac")
```

looks for an **a** not immediately followed by some positive number *n* of **a**'s, a **b**, another *n* **a**'s (specified by the first \2) and a **c**. The second \2 is outside the negative lookahead, so it matches against **undefined** and therefore always succeeds. The whole expression returns the array:

```
["baaabaac", "ba", undefined, "abaac"]
```

In case-insignificant matches all characters are implicitly converted to upper case immediately before they are compared. However, if converting a character to upper case would expand that character into more than one character (such as converting **ß** (\u00DF) into **SS**), then the character is left as-is instead. The character is also left as-is if it is not an ASCII character but converting it to upper case would make it into an ASCII character. This prevents Unicode characters such as \u0131 and \u017F from matching regular expressions such as `/[a-z]/i`, which are only intended to match

ASCII letters. Furthermore, if these conversions were allowed, then `/[^\w]/i` would match each of **a**, **b**, ..., **h**, but not **i** or **s**.

### 15.10.2.9 AtomEscape

The production `AtomEscape :: DecimalEscape` evaluates as follows:

1. Evaluate `DecimalEscape` to obtain an `EscapeValue E`.
2. If `E` is not a character then go to step 6.
3. Let `ch` be `E`'s character.
4. Let `A` be a one-element `CharSet` containing the character `ch`.
5. Call `CharacterSetMatcher(A, false)` and return its `Matcher` result.
6. `E` must be an integer. Let `n` be that integer.
7. If `n=0` or `n>NCapturingParens` then throw a **SyntaxError** exception.
8. Return an internal `Matcher` closure that takes two arguments, a `State x` and a `Continuation c`, and performs the following:
  1. Let `cap` be `x`'s `captures` internal array.
  2. Let `s` be `cap[n]`.
  3. If `s` is **undefined**, then call `c(x)` and return its result.
  4. Let `e` be `x`'s `endIndex`.
  5. Let `len` be `s`'s length.
  6. Let `f` be `e+len`.
  7. If `f>InputLength`, return **failure**.
  8. If there exists an integer `i` between 0 (inclusive) and `len` (exclusive) such that `Canonicalize(s[i])` is not the same character as `Canonicalize(Input [e+i])`, then return **failure**.
  9. Let `y` be the `State (f, cap)`.
  10. Call `c(y)` and return its result.

The production `AtomEscape :: CharacterEscape` evaluates as follows:

1. Evaluate `CharacterEscape` to obtain a character `ch`.
2. Let `A` be a one-element `CharSet` containing the character `ch`.
3. Call `CharacterSetMatcher(A, false)` and return its `Matcher` result.

The production `AtomEscape :: CharacterClassEscape` evaluates as follows:

1. Evaluate `CharacterClassEscape` to obtain a `CharSet A`.
2. Call `CharacterSetMatcher(A, false)` and return its `Matcher` result.

**Informative comments:** An escape sequence of the form `\` followed by a nonzero decimal number `n` matches the result of the `n`th set of capturing parentheses (see 15.10.2.11). It is an error if the regular expression has fewer than `n` capturing parentheses. If the regular expression has `n` or more capturing parentheses but the `n`th one is **undefined** because it hasn't captured anything, then the backreference always succeeds.

### 15.10.2.10 CharacterEscape

The production `CharacterEscape :: ControlEscape` evaluates by returning the character according to the table below:

<i>ControlEscape</i>	<i>Unicode Value</i>	<i>Name</i>	<i>Symbol</i>
<b>t</b>	<code>\u0009</code>	horizontal tab	<code>&lt;HT&gt;</code>
<b>n</b>	<code>\u000A</code>	line feed (new line)	<code>&lt;LF&gt;</code>
<b>v</b>	<code>\u000B</code>	vertical tab	<code>&lt;VT&gt;</code>
<b>f</b>	<code>\u000C</code>	form feed	<code>&lt;FF&gt;</code>
<b>r</b>	<code>\u000D</code>	carriage return	<code>&lt;CR&gt;</code>

The production `CharacterEscape :: c ControlLetter` evaluates as follows:

1. Let `ch` be the character represented by `ControlLetter`.
2. Let `i` be `ch`'s code point value.

3. Let *j* be the remainder of dividing *i* by 32.
4. Return the Unicode character numbered *j*.

The production *CharacterEscape* :: *HexEscapeSequence* evaluates by evaluating the CV of the *HexEscapeSequence* (see 7.8.4) and returning its character result.

The production *CharacterEscape* :: *UnicodeEscapeSequence* evaluates by evaluating the CV of the *UnicodeEscapeSequence* (see 7.8.4) and returning its character result.

The production *CharacterEscape* :: *IdentityEscape* evaluates by returning the character represented by *IdentityEscape*.

#### 15.10.2.11 DecimalEscape

The production *DecimalEscape* :: *DecimalIntegerLiteral* [lookahead ∉ *DecimalDigit*] evaluates as follows.

1. Let *i* be the MV of *DecimalIntegerLiteral*.
2. If *i* is zero, return the EscapeValue consisting of a <NUL> character (Unicode value 0000).
3. Return the EscapeValue consisting of the integer *i*.

The definition of “the MV of *DecimalIntegerLiteral*” is in 7.8.3.

**Informative comments:** If \ is followed by a decimal number *n* whose first digit is not 0, then the escape sequence is considered to be a backreference. It is an error if *n* is greater than the total number of left capturing parentheses in the entire regular expression. \0 represents the NUL character and cannot be followed by a decimal digit.

#### 15.10.2.12 CharacterClassEscape

The production *CharacterClassEscape* :: **d** evaluates by returning the ten-element set of characters containing the characters 0 through 9 inclusive.

The production *CharacterClassEscape* :: **D** evaluates by returning the set of all characters not included in the set returned by *CharacterClassEscape* :: **d**.

The production *CharacterClassEscape* :: **s** evaluates by returning the set of characters containing the characters that are on the right-hand side of the *WhiteSpace* (7.2) or *LineTerminator* (7.3) productions.

The production *CharacterClassEscape* :: **S** evaluates by returning the set of all characters not included in the set returned by *CharacterClassEscape* :: **s**.

The production *CharacterClassEscape* :: **w** evaluates by returning the set of characters containing the sixty-three characters:

```

a b c d e f g h i j k l m n o p q r s t u v w x y z
A B C D E F G H I J K L M N O P Q R S T U V W X Y Z
0 1 2 3 4 5 6 7 8 9 _

```

The production *CharacterClassEscape* :: **W** evaluates by returning the set of all characters not included in the set returned by *CharacterClassEscape* :: **w**.

#### 15.10.2.13 CharacterClass

The production *CharacterClass* :: [ [lookahead ∉ {^}] *ClassRanges* ] evaluates by evaluating *ClassRanges* to obtain a CharSet and returning that CharSet and the boolean **false**.

The production *CharacterClass* :: [ ^ *ClassRanges* ] evaluates by evaluating *ClassRanges* to obtain a CharSet and returning that CharSet and the boolean **true**.

#### 15.10.2.14 ClassRanges

The production *ClassRanges* :: [empty] evaluates by returning the empty CharSet.

The production *ClassRanges* :: *NonemptyClassRanges* evaluates by evaluating *NonemptyClassRanges* to obtain a CharSet and returning that CharSet.

pratapL 7/4/2008 10:07 AM

**Comment [55]:** From DEC:  
This class is pretty close to useless in its current form. We could make it more useful by having it match ECMAScript identifier characters. It could at least them be used to process ECMAScript programs.

pratapL 7/2/2008 2:10 PM

**Deleted: q**



#### 15.10.2.15 NonemptyClassRanges

The production *NonemptyClassRanges* :: *ClassAtom* evaluates by evaluating *ClassAtom* to obtain a CharSet and returning that CharSet.

The production *NonemptyClassRanges* :: *ClassAtom NonemptyClassRangesNoDash* evaluates as follows:

1. Evaluate *ClassAtom* to obtain a CharSet *A*.
2. Evaluate *NonemptyClassRangesNoDash* to obtain a CharSet *B*.
3. Return the union of CharSets *A* and *B*.

The production *NonemptyClassRanges* :: *ClassAtom - ClassAtom ClassRanges* evaluates as follows:

1. Evaluate the first *ClassAtom* to obtain a CharSet *A*.
2. Evaluate the second *ClassAtom* to obtain a CharSet *B*.
3. Evaluate *ClassRanges* to obtain a CharSet *C*.
4. Call *CharacterRange(A, B)* and let *D* be the resulting CharSet.
5. Return the union of CharSets *D* and *C*.

The internal helper function *CharacterRange* takes two CharSet parameters *A* and *B* and performs the following:

1. If *A* does not contain exactly one character or *B* does not contain exactly one character then throw a **SyntaxError** exception.
2. Let *a* be the one character in CharSet *A*.
3. Let *b* be the one character in CharSet *B*.
4. Let *i* be the code point value of character *a*.
5. Let *j* be the code point value of character *b*.
6. If  $i > j$  then throw a **SyntaxError** exception.
7. Return the set containing all characters numbered *i* through *j*, inclusive.

#### 15.10.2.16 NonemptyClassRangesNoDash

The production *NonemptyClassRangesNoDash* :: *ClassAtom* evaluates by evaluating *ClassAtom* to obtain a CharSet and returning that CharSet.

The production *NonemptyClassRangesNoDash* :: *ClassAtomNoDash NonemptyClassRangesNoDash* evaluates as follows:

1. Evaluate *ClassAtomNoDash* to obtain a CharSet *A*.
2. Evaluate *NonemptyClassRangesNoDash* to obtain a CharSet *B*.
3. Return the union of CharSets *A* and *B*.

The production *NonemptyClassRangesNoDash* :: *ClassAtomNoDash - ClassAtom ClassRanges* evaluates as follows:

1. Evaluate *ClassAtomNoDash* to obtain a CharSet *A*.
2. Evaluate *ClassAtom* to obtain a CharSet *B*.
3. Evaluate *ClassRanges* to obtain a CharSet *C*.
4. Call *CharacterRange(A, B)* and let *D* be the resulting CharSet.
5. Return the union of CharSets *D* and *C*.

**Informative comments:** *ClassRanges* can expand into single *ClassAtoms* and/or ranges of two *ClassAtoms* separated by dashes. In the latter case the *ClassRanges* includes all characters between the first *ClassAtom* and the second *ClassAtom*, inclusive; an error occurs if either *ClassAtom* does not represent a single character (for example, if one is `\w`) or if the first *ClassAtom*'s code point value is greater than the second *ClassAtom*'s code point value.

Even if the pattern ignores case, the case of the two ends of a range is significant in determining which characters belong to the range. Thus, for example, the pattern `/[E-F]/i` matches only the letters `E`, `F`, `e`, and `f`, while the pattern `/[E-f]/i` matches all upper and lower-case ASCII letters as well as the symbols `[`, `\`, `]`, `^`, `_`, and ```.

A - character can be treated literally or it can denote a range. It is treated literally if it is the first or last character of *ClassRanges*, the beginning or end limit of a range specification, or immediately follows a range specification.

#### 15.10.2.17 ClassAtom

The production *ClassAtom* :: - evaluates by returning the CharSet containing the one character -.

The production *ClassAtom* :: *ClassAtomNoDash* evaluates by evaluating *ClassAtomNoDash* to obtain a CharSet and returning that CharSet.

#### 15.10.2.18 ClassAtomNoDash

The production *ClassAtomNoDash* :: *SourceCharacter* but not one of \ ] - evaluates by returning a one-element CharSet containing the character represented by *SourceCharacter*.

The production *ClassAtomNoDash* :: \ *ClassEscape* evaluates by evaluating *ClassEscape* to obtain a CharSet and returning that CharSet.

#### 15.10.2.19 ClassEscape

The production *ClassEscape* :: *DecimalEscape* evaluates as follows:

1. Evaluate *DecimalEscape* to obtain an *EscapeValue E*.
2. If *E* is not a character then throw a **SyntaxError** exception.
3. Let *ch* be *E*'s character.
4. Return the one-element CharSet containing the character *ch*.

The production *ClassEscape* :: **b** evaluates by returning the CharSet containing the one character <BS> (Unicode value 0008).

The production *ClassEscape* :: *CharacterEscape* evaluates by evaluating *CharacterEscape* to obtain a character and returning a one-element CharSet containing that character.

The production *ClassEscape* :: *CharacterClassEscape* evaluates by evaluating *CharacterClassEscape* to obtain a CharSet and returning that CharSet.

**Informative comments:** A *ClassAtom* can use any of the escape sequences that are allowed in the rest of the regular expression except for \b, \B, and backreferences. Inside a *CharacterClass*, \b means the backspace character, while \B and backreferences raise errors. Using a backreference inside a *ClassAtom* causes an error.

### 15.10.3 The RegExp Constructor Called as a Function

#### 15.10.3.1 RegExp(pattern, flags)

If *pattern* is an object *R* whose [[Class]] property is "RegExp" and *flags* is **undefined**, then return *R* unchanged. Otherwise call the [standard built-in](#) RegExp constructor (15.10.4.1), passing it the *pattern* and *flags* arguments and return the object constructed by that constructor.

### 15.10.4 The RegExp Constructor

When **RegExp** is called as part of a **new** expression, it is a constructor: it initialises the newly created object.

#### 15.10.4.1 new RegExp(pattern, flags)

If *pattern* is an object *R* whose [[Class]] property is "RegExp" and *flags* is **undefined**, then let *P* be the *pattern* used to construct *R* and let *F* be the flags used to construct *R*. If *pattern* is an object *R* whose [[Class]] property is "RegExp" and *flags* is not **undefined**, then throw a **TypeError** exception. Otherwise, let *P* be the empty string if *pattern* is **undefined** and ToString(*pattern*) otherwise, and let *F* be the empty string if *flags* is **undefined** and ToString(*flags*) otherwise.

The **global** property of the newly constructed object is set to a Boolean value that is **true** if *F* contains the character "g" and **false** otherwise.

The **ignoreCase** property of the newly constructed object is set to a Boolean value that is **true** if *F* contains the character "i" and **false** otherwise.

The **multiline** property of the newly constructed object is set to a Boolean value that is **true** if *F* contains the character **"m"** and **false** otherwise.

If *F* contains any character other than **"g"**, **"i"**, or **"m"**, or if it contains the same one more than once, then throw a **SyntaxError** exception.

If *P*'s characters do not have the form *Pattern*, then throw a **SyntaxError** exception. Otherwise let the newly constructed object have a **[[Match]]** property obtained by evaluating ("compiling") *Pattern*. Note that evaluating *Pattern* may throw a **SyntaxError** exception. (Note: if *pattern* is a *StringLiteral*, the usual escape sequence substitutions are performed before the string is processed by **RegExp**. If *pattern* must contain an escape sequence to be recognised by **RegExp**, the **"\"** character must be escaped within the *StringLiteral* to prevent its being removed when the contents of the *StringLiteral* are formed.)

The **source** property of the newly constructed object is set to an implementation-defined string value in the form of a *Pattern* based on *P*.

The **lastIndex** property of the newly constructed object is set to **0**.

The **[[Prototype]]** property of the newly constructed object is set to the original **RegExp** prototype object, the one that is the initial value of **RegExp.prototype**.

The **[[Class]]** property of the newly constructed object is set to **"RegExp"**.

### 15.10.5 Properties of the RegExp Constructor

The value of the internal **[[Prototype]]** property of the **RegExp** constructor is the Function prototype object (15.3.4).

Besides the internal properties and the **length** property (whose value is **2**), the **RegExp** constructor has the following properties:

#### 15.10.5.1 RegExp.prototype

The initial value of **RegExp.prototype** is the **RegExp** prototype object (15.10.6).

This property shall have the attributes { **[[Writable]]**: **false**, **[[Enumerable]]**: **false**, **[[Flexible]]**: **false** }.

### 15.10.6 Properties of the RegExp Prototype Object

The value of the internal **[[Prototype]]** property of the **RegExp** prototype object is the Object prototype. The **RegExp** prototype object is itself a regular expression object; its **[[Class]]** is **"RegExp"**.

The **RegExp** prototype object does not have a **valueOf** property of its own; however, it inherits the **valueOf** property from the Object prototype object.

In the following descriptions of functions that are properties of the **RegExp** prototype object, the phrase "this **RegExp** object" refers to the object that is the **this** value for the invocation of the function; a **TypeError** exception is thrown if the **this** value is not an object for which the value of the internal **[[Class]]** property is **"RegExp"**.

#### 15.10.6.1 RegExp.prototype.constructor

The initial value of **RegExp.prototype.constructor** is the built-in **RegExp** constructor.

#### 15.10.6.2 RegExp.prototype.exec(string)

Performs a regular expression match of *string* against the regular expression and returns an Array object containing the results of the match, or **null** if the string did not match

The string **Tostring(string)** is searched for an occurrence of the regular expression pattern as follows:

1. Let *S* be the value of **Tostring(string)**.
2. Let *length* be the length of *S*.
3. Let *lastIndex* be the value of the **lastIndex** property.
4. Let *i* be the value of **ToInteger(lastIndex)**.
5. If the **global** property is **false**, let *i* = **0**.
6. If *I* < **0** or *I* > *length* then set **lastIndex** to **0** and return **null**.

pratapL 5/29/2008 12:41 AM  
Deleted: DontEnum, DontDelete, ReadOnly

pratapL 7/4/2008 10:07 AM  
Comment [56]: From AWB: Do any other properties, eg source, need to be specified?

pratapL 7/2/2008 2:12 PM  
Deleted: The value of the internal **[[Class]]** property of the **RegExp** prototype object is **"Object"**

7. Call `[[Match]]`, giving it the arguments `S` and `i`. If `[[Match]]` returned **failure**, go to step 8; otherwise let `r` be its State result and go to step 10.
8. Let `i = i+1`.
9. Go to step 6.
10. Let `e` be `r`'s `endIndex` value.
11. If the `global` property is **true**, set `lastIndex` to `e`.
12. Let `n` be the length of `r`'s `captures` array. (This is the same value as 15.10.2.1's `NCapturingParens`.)
13. Return a new array with the following properties:
  - The `index` property is set to the position of the matched substring within the complete string `S`.
  - The `input` property is set to `S`.
  - The `length` property is set to `n + 1`.
  - The `0` property is set to the matched substring (i.e. the portion of `S` between offset `i` inclusive and offset `e` exclusive).
  - For each integer `i` such that `i > 0` and `i ≤ n`, set the property named `ToString(i)` to the  $i^{\text{th}}$  element of `r`'s `captures` array.

### 15.10.6.3 `RegExp.prototype.test(string)`

Equivalent to the expression `RegExp.prototype.exec(string) != null`.

### 15.10.6.4 `RegExp.prototype.toString()`

Let `src` be a string in the form of a *Pattern* representing the current regular expression. `src` may or may not be identical to the `source` property or to the source code supplied to the `RegExp` constructor; however, if `src` were supplied to the `RegExp` constructor along with the current regular expression's flags, the resulting regular expression must behave identically to the current regular expression.

`toString` returns a string value formed by concatenating the strings `"/"`, `src`, and `"/"`; plus `"g"` if the `global` property is **true**, `"i"` if the `ignoreCase` property is **true**, and `"m"` if the `multiline` property is **true**.

#### NOTE

An implementation may choose to take advantage of `src` being allowed to be different from the source passed to the `RegExp` constructor to escape special characters in `src`. For example, in the regular expression obtained from `new RegExp("/")`, `src` could be, among other possibilities, `"/"` or `"\"`. The latter would permit the entire result (`"/\"`) of the `toString` call to have the form `RegularExpressionLiteral`.

## 15.10.7 Properties of `RegExp` Instances

`RegExp` instances inherit properties from their `[[Prototype]]` object as specified above and also have the following properties.

### 15.10.7.1 `source`

The value of the `source` property is string in the form of a *Pattern* representing the current regular expression. This property shall have the attributes { `[[Writable]]: false`, `[[Enumerable]]: false`, `[[Flexible]]: false` }.

### 15.10.7.2 `global`

The value of the `global` property is a Boolean value indicating whether the flags contained the character `"g"`. This property shall have the attributes { `[[Writable]]: false`, `[[Enumerable]]: false`, `[[Flexible]]: false` }.

### 15.10.7.3 `ignoreCase`

The value of the `ignoreCase` property is a Boolean value indicating whether the flags contained the character `"i"`. This property shall have the attributes { `[[Writable]]: false`, `[[Enumerable]]: false`, `[[Flexible]]: false` }.

pratapL 5/29/2008 12:42 AM  
Deleted: DontDelete, ReadOnly, DontEnum

pratapL 5/29/2008 12:42 AM  
Deleted: DontDelete, ReadOnly, DontEnum

pratapL 5/29/2008 12:43 AM  
Deleted: DontDelete, ReadOnly, DontEnum

#### 15.10.7.4 multiline

The value of the `multiline` property is a Boolean value indicating whether the flags contained the character "m". This property shall have the attributes { `[[Writable]]: false, [[Enumerable]]: false, [[Flexible]]: false` }.

#### 15.10.7.5 lastIndex

The value of the `lastIndex` property is an integer that specifies the string position at which to start the next match. This property shall have the attributes { `[[Writable]]: false, [[Enumerable]]: false, [[Flexible]]: false` }.

pratapL 5/29/2008 12:43 AM  
Deleted: DontDelete, ReadOnly, DontEnum

pratapL 6/30/2008 10:40 PM  
Deleted: DontDelete, DontEnum

### 15.11 Error Objects

Instances of Error objects are thrown as exceptions when runtime errors occur. The Error objects may also serve as base objects for user-defined exception classes.

#### 15.11.1 The Error Constructor Called as a Function

When `Error` is called as a function rather than as a constructor, it creates and initialises a new Error object. Thus the function call `Error(...)` is equivalent to the object creation expression `new Error(...)` with the same arguments.

##### 15.11.1.1 Error (message)

The `[[Prototype]]` property of the newly constructed object is set to the original Error prototype object, the one that is the initial value of `Error.prototype` (15.11.3.1).

The `[[Class]]` property of the newly constructed object is set to `"Error"`.

[The `\[\[Extensible\]\]` property of the newly constructed object is set to `true`.](#)

If the argument `message` is not `undefined`, the `message` property of the newly constructed object is set to `ToString(message)`. Otherwise, the `message` property is set to the empty string.

pratapL 7/4/2008 10:07 AM  
Comment [57]: ALP: Should this just defer to 15.11.2.1?

#### 15.11.2 The Error Constructor

When `Error` is called as part of a `new` expression, it is a constructor: it initialises the newly created object.

##### 15.11.2.1 new Error (message)

The `[[Prototype]]` property of the newly constructed object is set to the original Error prototype object, the one that is the initial value of `Error.prototype` (15.11.3.1).

The `[[Class]]` property of the newly constructed Error object is set to `"Error"`.

[The `\[\[Extensible\]\]` property of the newly constructed object is set to `true`.](#)

If the argument `message` is not `undefined`, the `message` property of the newly constructed object is set to `ToString(message)`.

#### 15.11.3 Properties of the Error Constructor

The value of the internal `[[Prototype]]` property of the Error constructor is the Function prototype object (15.3.4).

Besides the internal properties and the `length` property (whose value is `1`), the Error constructor has the following property:

##### 15.11.3.1 Error.prototype

The initial value of `Error.prototype` is the Error prototype object (15.11.4).

This property has the attributes { `[[Writable]]: false, [[Enumerable]]: false, [[Flexible]]: false` }.

pratapL 5/29/2008 12:44 AM  
Deleted: DontEnum, DontDelete, ReadOnly

#### 15.11.4 Properties of the Error Prototype Object

The Error prototype object is itself an Error object (its `[[Class]]` is `"Error"`).

The value of the internal `[[Prototype]]` property of the Error prototype object is the Object prototype object (15.2.3.1).

pratapL 7/4/2008 10:07 AM  
Comment [58]: Herman Venter says these do not have specified attributes.

#### 15.11.4.1 **Error.prototype.constructor**

The initial value of `Error.prototype.constructor` is the built-in `Error` constructor.

#### 15.11.4.2 **Error.prototype.name**

The initial value of `Error.prototype.name` is `"Error"`.

#### 15.11.4.3 **Error.prototype.message**

The initial value of `Error.prototype.message` is an implementation-defined string.

#### 15.11.4.4 **Error.prototype.toString ()**

Returns an implementation defined string.

#### 15.11.5 **Properties of Error Instances**

Error instances have no special properties beyond those inherited from the `Error` prototype object.

#### 15.11.6 **Native Error Types Used in This Standard**

One of the `NativeError` objects below is thrown when a runtime error is detected. All of these objects share the same structure, as described in 15.11.7.

##### 15.11.6.1 **EvalError**

Indicates that the global function `eval` was used in a way that is incompatible with its definition. See 15.1.2.1.

##### 15.11.6.2 **RangeError**

Indicates a numeric value has exceeded the allowable range. See 15.4.2.2, 15.4.5.1, 15.7.4.5, 15.7.4.6, and 15.7.4.7.

##### 15.11.6.3 **ReferenceError**

Indicate that an invalid reference value has been detected. See 8.7.1, and 8.7.2.

##### 15.11.6.4 **SyntaxError**

Indicates that a parsing error has occurred. See 15.1.2.1, 15.3.2.1, 15.10.2.5, 15.10.2.9, 15.10.2.15, 15.10.2.19, and 15.10.4.1.

##### 15.11.6.5 **TypeError**

Indicates the actual type of an operand is different than the expected type. See 8.6.2, 8.6.2.6, 9.9, 11.2.2, 11.2.3, 11.8.6, 11.8.7, 15.3.4.2, 15.3.4.3, 15.3.4.4, 15.3.5.3, 15.4.4.2, 15.4.4.3, 15.5.4.2, 15.5.4.3, 15.6.4, 15.6.4.2, 15.6.4.3, 15.7.4, 15.7.4.2, 15.7.4.4, 15.9.5, 15.9.5.9, 15.9.5.27, 15.10.4.1, and 15.10.6.

##### 15.11.6.6 **URIError**

Indicates that one of the global URI handling functions was used in a way that is incompatible with its definition. See 15.1.3.

#### 15.11.7 **NativeError Object Structure**

When an ECMAScript implementation detects a runtime error, it throws an instance of one of the `NativeError` objects defined in 15.11.6. Each of these objects has the structure described below, differing only in the name used as the constructor name instead of `NativeError`, in the `name` property of the prototype object, and in the implementation-defined `message` property of the prototype object.

For each error object, references to `NativeError` in the definition should be replaced with the appropriate error object name from 15.11.6.

##### 15.11.7.1 **NativeError Constructors Called as Functions**

When a `NativeError` constructor is called as a function rather than as a constructor, it creates and initialises a new object. A call of the object as a function is equivalent to calling it as a constructor with the same arguments.

pratapL 7/4/2008 10:07 AM

**Comment [59]:** Deviations doc item 3.37 suggests codifying this behaviour.

#### 15.11.7.2 *NativeError* (message)

The `[[Prototype]]` property of the newly constructed object is set to the prototype object for this error constructor. The `[[Class]]` property of the newly constructed object is set to `"Error"`. [The `\[\[Extensible\]\]` property of the newly constructed object is set to `true`.](#)

If the argument `message` is not `undefined`, the `message` property of the newly constructed object is set to `ToString(message)`.

#### 15.11.7.3 The *NativeError* Constructors

When a *NativeError* constructor is called as part of a `new` expression, it is a constructor: it initialises the newly created object.

#### 15.11.7.4 New *NativeError* (message)

The `[[Prototype]]` property of the newly constructed object is set to the prototype object for this *NativeError* constructor. The `[[Class]]` property of the newly constructed object is set to `"Error"`. [The `\[\[Extensible\]\]` property of the newly constructed object is set to `true`.](#)

If the argument `message` is not `undefined`, the `message` property of the newly constructed object is set to `ToString(message)`.

#### 15.11.7.5 Properties of the *NativeError* Constructors

The value of the internal `[[Prototype]]` property of a *NativeError* constructor is the Function prototype object (15.3.4).

Besides the internal properties and the `length` property (whose value is `1`), each *NativeError* constructor has the following property:

#### 15.11.7.6 *NativeError*.prototype

The initial value of `NativeError.prototype` is a *NativeError* prototype object (15.11.7.7). Each *NativeError* constructor has a separate prototype object.

This property has the attributes `{ [[Writable]]: false, [[Enumerable]]: false, [[Flexible]]: false }`.

#### 15.11.7.7 Properties of the *NativeError* Prototype Objects

Each *NativeError* prototype object is an Error object (its `[[Class]]` is `"Error"`).

The value of the internal `[[Prototype]]` property of each *NativeError* prototype object is the Error prototype object (15.11.4).

#### 15.11.7.8 *NativeError*.prototype.constructor

The initial value of the `constructor` property of the prototype for a given *NativeError* constructor is the *NativeError* constructor function itself (15.11.7).

#### 15.11.7.9 *NativeError*.prototype.name

The initial value of the `name` property of the prototype for a given *NativeError* constructor is the name of the constructor (the name used instead of *NativeError*).

#### 15.11.7.10 *NativeError*.prototype.message

The initial value of the `message` property of the prototype for a given *NativeError* constructor is an implementation-defined string.

#### NOTE

*The prototypes for the *NativeError* constructors do not themselves provide a `toString` function, but instances of errors will inherit it from the Error prototype object.*

#### 15.11.7.11 Properties of *NativeError* Instances

*NativeError* instances have no special properties beyond those inherited from the Error prototype object.

pratapL 5/29/2008 12:45 AM

Deleted: DontEnum, DontDelete, ReadOnly

## 15.12 JSON

The **JSON** object is a single object that contains two functions, **parse** and **stringify**, that are used to parse and construct JSON texts. The JSON Data Interchange Format is described in RFC 4627 <<http://www.ietf.org/rfc/rfc4627.txt?number=4627>>.

The value of the internal `[[Prototype]]` property of the JSON object is the Object prototype object (15.2.3.1). The value of the internal `[[Class]]` property of the JSON object is **"JSON"**. The value of the `[[Extensible]]` property of the JSON object is set to **true**.

The JSON object does not have a `[[Construct]]` property; it is not possible to use the JSON object as a constructor with the **new** operator.

The JSON object does not have a `[[Call]]` property; it is not possible to invoke the JSON object as a function.

### 15.12.1 parse ( text, reviver )

The **parse** function parses a JSON text (a JSON formatted string) and produces a ECMAScript value. The JSON format is a restricted form of ECMAScript literal. JSON objects are realized as ECMAScript objects. JSON Arrays are realized as ECMAScript arrays. JSON strings, numbers, booleans, and null are realized as ECMAScript strings, numbers, booleans, and null. JSON uses a more limited set of white space characters than *WhiteSpace*.

The optional **reviver** parameter is a function that takes two parameters, (key, value). It can filter and transform the results. It is called with each of the key/value pairs produced by the parse, and its return value is used instead of the original value. If it returns what it received, the structure is not modified. If it returns **undefined** then the member is deleted from the result.

1. Let *T* be the string obtained by ToString of *text*.
2. Let *V* be the value obtained by parsing *T*. Throw a **SyntaxError** exception if the text did not conform to the JSON grammar.
3. If the type of the reviver parameter is 'function'
  - a. Return walk( `{ "": V }`, `""` ). The walk function is an internal function described below.
4. Else
  - a. Return *V*.

The internal walk function is an internal recursive function that takes two parameters: a holder object and the name of a property in that object.

1. Let *O* be *holder[key]*.
2. If *O* is an object or array
  - a. For *I* being each own property name in *O*
    - i. Let *w* be walk(*V*, *I*).
    - ii. If *w* is **undefined**
      1. Delete *I* from *O*.
    - iii. Else
      1. Let *O[I]* be *w*.
3. Return *reviver.call(holder, key, O)*.

### 15.12.2 stringify ( value, replacer, space )

The **stringify** function produces a JSON formatted string that captures information from a JavaScript value. It can take three parameters. The first parameter is required. The *value* parameter is a JavaScript value, usually an object or array. The optional *replacer* parameter is either a function that alters the way objects and arrays are stringified, or an array of strings that acts as a whitelist for selecting the keys that will be stringified. The optional *space* parameter is a string or number that allows the result to have white space injected into it to improve human readability.

JSON structures are allowed to be nested, but they must be acyclic. If the value is a cyclic structure, then the **stringify** function must throw an Error. This is an example of a value that cannot be stringified:

```
a = [ ];
a[0] = a;
```

pratapL 7/4/2008 10:07 AM

**Comment [60]:** From DEC: Using Math as the model for the JSON object. I am not aware that `[[Class]]` is seen anywhere except in the useless text returned by `object.toString`. I see no harm in JSON being mutable. Caja can lock it down if it wants to.



`my text = JSON.stringify(a); // This must throw an Error.`

The **null** value is rendered in JSON text as the string `null`.

The **true** value is rendered in JSON text as the string `true`.

The **false** value is rendered in JSON text as the string `false`.

String values are wrapped in double quotes. The characters `"` and `\` are escaped with `\` prefixes. Control characters are replaced with escape sequences `\uHHHH`, or with the shorter forms, `\b` (backspace), `\f` (formfeed), `\n` (newline), `\r` (carriage return), `\t` (tab).

Finite numbers are stringified by **String(number)**. **NaN** and **Infinity** regardless of sign are represented as the string `null`.

Values that do not have a JSON representation (such as **undefined** and functions) do not produce a string. Instead they produce the undefined value. In arrays these values are represented as the string `null`. In objects an unrepresentable value causes the property to be excluded from stringification.

The process of stringifying an object is more complicated because it is a more complicated value, and because there are features that allow the programmer some control over the stringification. An object is rendered as an opening left brace followed by zero or more properties, separated with commas, closed with a right brace. A property is a quoted string representing the key or property name, a colon, and then the stringified property value.

These are the steps in stringifying an object:

1. If the **replacer** parameter is an array
  - a. Let **K** be the **replacer** parameter.
2. Else
  - a. Let **K** be the array that is the result of calling the standard built-in method **Object.keys(object, true)**.
3. Let **S** be `'{'`.
4. Let **F** be false.
5. For each **KEY** string in **K**
  - a. Let **V** be **object[KEY]**.
  - b. If the **typeof V** is `'function'`
    - i. Let **V** be **object.toJSON(KEY)**.
  - c. If the **typeof the replacer parameter** is `'function'`
    - i. Let **V** be **V.call(object, KEY, V)**.
  - d. Let **T** be the stringification of **V**. At this step, the algorithm recurses. Throw an exception if an infinite recursion occurs.
  - e. If the **typeof T** is a string
    - i. If **F** is true
      1. Append `','` to **S**.
    - ii. Append the stringification of the **KEY** string to **S**. This will wrap it in quotes with escapement.
    - iii. Append `':'` to **S**.
    - iv. Append the stringification of **V** to **S**.
    - v. Let **F** be true.
6. Append `'}'` to **S**.
7. Return **S**.

The representation of arrays includes only the elements between zero and **array.length - 1**. Named properties are excluded from the stringification. An array is stringified as an open left bracket, elements separated by comma, and a closing right bracket.

These are the steps in stringifying an array:

1. Let **S** be `'['`.
2. Let **F** be false.
3. For **I** from 0 to (**array.length - 1**)
  - a. Let **V** be **array[I]**.

- b. If the `typeof V.toJSON` is 'function'
    - i. Let `V` be `array.toJSON(I)`.
  - c. If the `typeof` the `replacer` parameter is 'function'
    - i. Let `V` be `replacer.call(array, I, V)`.
  - d. If `F` is true
    - i. Append `' '` to `S`.
  - e. Let `T` be the stringification of `V`.
  - f. If the `typeof T` is 'string'
    - i. Append `T` to `S`.
  - g. Else
    - i. Append `'null'` to `S`.
  - h. Let `F` be true.
4. Append `' '` to `S`.
  5. Return `S`.

If the `space` parameter is provided, white space will be inserted at various places:

- One space after every colon;
- A linefeed and a quantity of white space after every open left brace (or left bracket for arrays), after every comma, and before the closing right brace (or right bracket for arrays). The `space` parameter indicates the basic quantity of white space in a level of indentation. The `space` parameter can be a string such as `'t'`, or it can be a number, indicating the number of spaces, such as 4. The amount of space is increased after each left brace or left bracket, and decreased before each right brace or right bracket. The insertion of white space after the open left brace or bracket and before the closing right brace or right bracket is suppressed if fewer than two members (or array elements) are stringified.

## 15.13 Decimal

### 15.13.1 Overview of Decimal Objects and Definitions of Internal Operators

A Decimal object contains an IEEE 754r decimal-encoded 34-digit floating point number.

#### 15.13.1.1 UnscaledValue

A 34 digit integer, stored exactly.

#### 15.13.1.2 Scale

The number of digits to the right of the decimal point. If negative, the unscaled value of the number is multiplied by ten to the power of the negation of the scale.

#### 15.13.1.3 Value

The value formed by computing `UnscaledValue * (10**Scale)`.

### 15.13.2 The Decimal Constructor Called as a Function

The Decimal object does not support the internal `[[Call]]` method. The Decimal constructor cannot be invoked as a function.

### 15.13.3 The Decimal Constructor

When Decimal is called as part of a `new` expression it is a constructor: it initialises the newly created object.

#### 15.13.3.1 new Decimal ( string )

Translates the string representation of a Decimal into a Decimal. The string representation consists of an optional sign, '+' (`\u002B`) or '-' (`\u002D`), followed by a sequence of zero or more decimal digits ("the integer"), optionally followed by a fraction, optionally followed by an exponent.

The `[[Prototype]]` property of the newly constructed object is set to the original Decimal prototype object, the one that is the initial value of `Decimal.prototype` (15.13.3.1).

The `[[Class]]` property of the newly constructed Decimal object is set to "Decimal".

The `[[Extensible]]` property of the newly constructed object is set to `false`.

The `[[Writable]]` property of the newly constructed object is set to `false`.

For decimal numbers, the radix is always 10.

pratapL 7/4/2008 10:07 AM

**Comment [61]:** From Sam:  
 The overall approach is to add support to ECMAScript for decimal numbers modelled after, but not making reference to, Java's `BigDecimal` class. Features that were omitted from the ECMAScript 3.1 subset are as follows:

- Operator overloading. ECMAScript 3.1 users will need to explicitly use named functions, such as `add`.
- Transcendental functions, like `sin`. Despite the fact that these functions are already a part of the ECMAScript standard, there was a concern expressed about footprint size.
- User definable precision. Instead of providing the option for 7, 16, 34, or unlimited number of digits, 34 has been selected for ECMAScript 3.1.

Notes:

- ECMAScript 3.1 does not have namespaces. In order to reduce namespace pollution, Java's `MathContext` and `RoundingMode` classes have been subsumed into the `Decimal.prototype` object.
- It is my belief that operators such as `ToPrimitive`, `GetValue` and `GetBase` as well as Internal Properties such as `[[DefaultValue]]` should "just work". Independent confirmation (or noting where such will not work) would be appreciated.
- I am considerably less comfortable that I have the values for the following properties specified correctly: `[[Writable]]`, `[[Enumerable]]`, `[[Dynamic]]`. The intent is that Decimal objects, once constructed, are immutable, and that developers can create new prototype objects based on the Decimal prototype, most notably in order to vary the value of the `roundingMode` property.
- Not in this revision, but we should consider allowing arguments which are Number objects whose value contain pure integral values to the following Decimal methods: `add`, `subtract`, `multiply`, `divide`, `divideAndRemainder`, `divideToIntegerValue`, and `remainder`.

Sources:

- P754 Draft Standard for Floating-Point Arithmetic, May 23, 2008
- [BigDecimal \(Java 2 Platform SE 5.0\)](#)
- [General Decimal Arithmetic — IBM Hursley](#)
- [bigdecimal: Ruby Standard Library Documentation](#)

The fraction consists of a decimal point followed by zero or more decimal digits. The string must contain at least one digit in either the integer or the fraction. The number formed by the sign, the integer and the fraction is referred to as the significand.

The exponent consists of the character 'e' ('\u0075') or 'E' ('\u0045') followed by one or more decimal digits.

If the string does not meet these conditions, a **RangeError** exception is thrown.

#### 15.13.4 Properties of the Decimal constructor

The value of the internal `[[Prototype]]` property of the Decimal constructor is the Function prototype object (15.3.4).

Besides the internal properties and the `length` property (whose value is 1), the Decimal constructor has the following properties:

##### 15.13.4.1 Decimal.valueOf ( number )

Translates a Number into a Decimal, using the string representation provided by the `Number.toString` method. If val is **Infinity** or **NaN**, a **RangeError** exception is thrown instead.

##### 15.13.4.2 Decimal.prototype

The initial value of `Decimal.prototype` is the Decimal prototype object. This property has the attributes `{ [[Writable]]: false, [[Enumerable]]: false, [[Flexible]]: false }`.

#### 15.13.5 Properties of the Decimal Prototype Object

The Decimal prototype object is itself a Decimal object (its `[[Class]]` is "Decimal").

The value of the internal `[[Prototype]]` property of the Decimal prototype object is the Object prototype object (15.2.3.1).

##### 15.13.5.1 Decimal.prototype.constructor

The initial value of `Decimal.prototype.constructor` is the built-in Decimal constructor.

##### 15.13.5.2 Decimal.prototype.name

The initial value of `Decimal.prototype.name` is "Decimal".

##### 15.13.5.3 Decimal.prototype.roundingMode

The initial value of `Decimal.prototype.roundingMode` is 6. This corresponds to the value of `Decimal.prototype.HALF_EVEN`.

##### 15.13.5.4 Decimal.prototype.constructor

The initial value of `Decimal.prototype.constructor` is the built-in Decimal constructor.

##### 15.13.5.5 Decimal.prototype.toString ( )

1. If the value is **NaN**, return 'NaN'
2. If the value is **Infinity**, return 'Infinity'
3. If the value is **Zero**, return '0'
4. Convert the coefficient to a string in base 10 using the characters 0 through 9 with no leading zeros.
5. Compute the exponent, plus the number of characters in the converted coefficient, less one. That is, `exponent+(clength-1)`, where `clength` is the length of the coefficient in decimal digits.
6. If the exponent is less than or equal to zero and the `Result(5)` is greater than or equal to -6, the number will be converted to a character form without using exponential notation. In this case, if the exponent is zero then no decimal point is added. Otherwise (the exponent will be negative), a decimal point will be inserted with the absolute value of the exponent specifying the number of characters to the right of the decimal point. '0' characters are added to the left of the converted coefficient as necessary. If no character precedes the decimal point after this insertion then a conventional '0' character is prefixed.
7. Otherwise (that is, if the exponent is positive, or the `Result(5)` is less than -6), the number will be converted to a character form using exponential notation. In this case, if the converted coefficient has more than one digit a decimal point is inserted after the first digit. An exponent in character form is then suffixed to the converted coefficient (perhaps with inserted decimal point); this

comprises the letter 'E' followed immediately by the Result(5) converted to a character form. The latter is in base ten, using the characters 0 through 9 with no leading zeros, always prefixed by a sign character ('-' if the calculated exponent is negative, '+' otherwise).

8. In all cases, the entire string is prefixed by a minus sign character ('-') if this.signum() is -1. No sign character is prefixed if this.signum() is 0 or 1.

#### **15.13.5.6 Decimal.prototype.toEngineeringString ()**

Returns a string representation of this Decimal, using engineering notation if an exponent is needed.

Returns a string that represents the Decimal as described in the toString() method, except that if exponential notation is used, the power of ten is adjusted to be a multiple of three (engineering notation) such that the integer part of nonzero values will be in the range 1 through 999. If exponential notation is used for zero values, a decimal point and one or two fractional zero digits are used so that the scale of the zero value is preserved. Note that unlike the output of toString(), the output of this method is not guaranteed to recover the same scale() and unscaledValue() of this Decimal if the output string is converting back to a Decimal using the string constructor. The result of this method meets the weaker constraint of always producing a numerically equal result from applying the string constructor to the method's output.

#### **15.13.5.7 Decimal.prototype.toPlainString ()**

Returns a string representation of this Decimal without an exponent field. For values with a positive scale, the number of digits to the right of the decimal point is used to indicate scale. For values with a zero or negative scale, the resulting string is generated as if the value were converted to a numerically equal value with zero scale and as if all the trailing zeros of the zero scale value were present in the result. The entire string is prefixed by a minus sign character '-' ('\u002D') if the unscaled value is less than zero. No sign character is prefixed if the unscaled value is zero or positive. Note that if the result of this method is passed to the string constructor, only the numerical value of this Decimal will necessarily be recovered; the representation of the new Decimal may have a different scale. In particular, if this Decimal has a positive scale, the string resulting from this method will have a scale of zero when processed by the string constructor.

#### **15.13.5.8 Decimal.prototype.CEILING**

Rounding mode to round towards positive infinity.

Value is the number 2.

#### **15.13.5.9 Decimal.prototype.DOWN**

Rounding mode to round towards zero.

Value is the number 1.

#### **15.13.5.10 Decimal.prototype.FLOOR**

Rounding mode to round towards negative infinity.

Value is the number 3.

#### **15.13.5.11 Decimal.prototype.HALF\_DOWN**

Rounding mode to round towards "nearest neighbour" unless both neighbours are equidistant, in which case round down.

Value is the number 5.

#### **15.13.5.12 Decimal.prototype.HALF\_EVEN**

Rounding mode to round towards the "nearest neighbour" unless both neighbours are equidistant, in which case, round towards the even neighbour.

Value is the number 6.

#### **15.13.5.13 Decimal.prototype.HALF\_UP**

Rounding mode to round towards "nearest neighbour" unless both neighbours are equidistant, in which case round up.

Value is the number 4.

#### **15.13.5.14 Decimal.prototype.UNNECESSARY**

Rounding mode to assert that the requested operation has an exact result, hence no rounding is necessary.

Value is the number 7.

#### **15.13.5.15 Decimal.prototype.UP**

Rounding mode to round away from zero.

Value is the number 0.

#### **15.13.5.16 Decimal.prototype.abs ( )**

Create and initialise a new Decimal object whose value is the absolute value of this Decimal, and whose scale is this.scale().

#### **15.13.5.17 Decimal.prototype.add ( augend [, mc] )**

If the *augend* is not a Decimal object, a **TypeError** exception is thrown.

If *mc* is not **undefined** and *mc* does not have a *roundingMode* property, a **TypeError** exception is thrown.

If *mc* is not **undefined** and the *roundingMode* property of the *mc* object has a value other than an integer in the range of 0 through 7, a **ValueError** exception is thrown.

Create and initialise a new Decimal object whose value is (this + *augend*), and whose *scale* is max(this.scale(), *augend*.scale()).

If *mc* is not undefined, then rounding will occur according to the context settings.

#### **15.13.5.18 Decimal.prototype.compareTo ( val )**

Compares this Decimal with the specified Decimal. Two Decimal objects that are equal in value but have a different scale (like 2.0 and 2.00) are considered equal by this method.

1. If the *val* is not a Decimal object, a **TypeError** is thrown.
2. If this Decimal is numerically less than *val*, return -1.
3. If this Decimal is numerically greater than *val*, return 1.
4. Return 0.

#### **15.13.5.19 Decimal.prototype.divide ( divisor, scale [, roundingMode] )**

If the *divisor* is not a Decimal object, a **TypeError** exception is thrown.

If *divisor* is zero, a **RangeError** exception is thrown.

If *roundingMode* is not **undefined** and not in the range of 0 through 7, a **RangeError** exception is thrown.

Create and initialise a new Decimal object whose value is (this / *divisor*), with rounding according to *roundingMode* argument if not **undefined**, otherwise rounding according to the prototype settings of this object.

#### **15.13.5.20 Decimal.prototype.divideAndRemainder ( divisor [, mc] )**

If the *divisor* is not a Decimal object, a **TypeError** exception is thrown.

If *divisor* is zero, a **RangeError** exception is thrown.

If *mc* is not **undefined** and *mc* does not have a *roundingMode* property, a **TypeError** exception is thrown.

If *mc* is not undefined and the *roundingMode* property of the *mc* object has a value other than an integer in the range of 0 through 7, a **ValueError** exception is thrown.

Create and initialise a new Decimal object whose element Decimal array containing the result of *divideToIntegerValue* followed by the result of *remainder* on the two operands calculated with rounding according to the context settings if not **undefined**, otherwise rounding according to the prototype settings of this object.

Note that if both the integer quotient and remainder are needed, this method is faster than using the `divideToIntegralValue` and `remainder` methods separately because the division need only be carried out once.

#### **15.13.5.21 `Decimal.prototype.divideToIntegralValue (divisor)`**

If the *divisor* is not a `Decimal` object, a **`TypeError`** exception is thrown.

If *divisor* is zero, a **`RangeError`** exception is thrown.

Create and initialise a new `Decimal` object whose value is the integer part of the quotient (`this / divisor`) rounded down. The preferred scale of the result is `(this.scale() - divisor.scale())`.

#### **15.13.5.22 `Decimal.prototype.doubleValue ()`**

Equivalent to `parseFloat(this.toString())`.

#### **15.13.5.23 `Decimal.prototype.equals (val)`**

If the *val* is not a `Decimal` object, a `TypeError` is thrown.

Compares this `Decimal` with the specified `Object` for equality. Unlike `compareTo`, this method considers two `Decimal` objects equal only if they are equal in value and scale (thus 2.0 is not equal to 2.00 when compared by this method)

#### **15.13.5.24 `Decimal.prototype.intValue ()`**

Equivalent to `parseInt(this.toString())`.

#### **15.13.5.25 `Decimal.prototype.intValueExtract ()`**

Converts this `Decimal` to an integer, checking for lost information. If this `Decimal` has a nonzero fractional part or is out of the possible range for an integer result then a **`RangeError`** exception is thrown.

#### **15.13.5.26 `Decimal.prototype.max (val)`**

If the *val* is not a `Decimal` object, a `TypeError` is thrown.

Return the `Decimal` object whose value is the greater of this `Decimal` and *val*. If they are equal, as defined by the `compareTo` method, **`this`** is returned.

#### **15.13.5.27 `Decimal.prototype.min (val)`**

If the *val* is not a `Decimal` object, a `TypeError` is thrown.

Return the `Decimal` object whose value is the lesser of this `Decimal` and *val*. If they are equal, as defined by the `compareTo` method, **`this`** is returned.

#### **15.13.5.28 `Decimal.prototype.movePointLeft (n)`**

If the type of *n* is not `Number` and the value of *n* is not an exact integer, throw a **`TypeError`** exception.

Create and initialise a new `Decimal` object whose is equivalent to this one with the decimal point moved *n* places to the left. If *n* is non-negative, the call merely adds *n* to the scale. If *n* is negative, the call is equivalent to `movePointRight(-n)`. The `Decimal` returned by this call has value `(this × 10**(-n))` and scale `max(this.scale()+n, 0)`.

#### **15.13.5.29 `Decimal.prototype.movePointRight (n)`**

If the type of *n* is not `Number` and the value of *n* is not an exact integer, throw `TypeError`.

Create and initialise a new `Decimal` object whose is equivalent to this one with the decimal point moved *n* places to the right. If *n* is non-negative, the call merely subtracts *n* from the scale. If *n* is negative, the call is equivalent to `movePointLeft(-n)`. The `Decimal` returned by this call has value `(this × 10**n)` and scale `max(this.scale()-n, 0)`.

#### **15.13.5.30 `Decimal.prototype.multiply (multiplicand [, mc])`**

If the *multiplicand* is not a `Decimal` object, a **`TypeError`** exception is thrown.

If *mc* is not undefined and *mc* does not have a `roundingMode` property, a **`TypeError`** exception is thrown.

If *mc* is not **undefined** and the *roundingMode* property of the *mc* object has a value other than an integer in the range of 0 through 7, a **ValueError** exception is thrown.

Create and initialise a new Decimal object whose value is (**this** × *multiplicand*), with rounding according to the context settings if not undefined, otherwise rounding according to the prototype settings of this object.

#### 15.13.5.31 **Decimal.prototype.negate ( [mc] )**

If *mc* is not undefined and *mc* does not have a *roundingMode* property, a **TypeError** exception is thrown.

If *mc* is not undefined and the *roundingMode* property of the *mc* object has a value other than an integer in the range of 0 through 7, a **ValueError** exception is thrown.

Create and initialise a new Decimal object whose value is (-**this**), and whose scale is *this.scale()*, with rounding according to the context settings, if not undefined.

#### 15.13.5.32 **Decimal.prototype.plus ( )**

Create and initialise a new Decimal object whose value is (+**this**), and whose scale is *this.scale()*, with rounding according to the context settings, if not undefined.

#### 15.13.5.33 **Decimal.prototype.pow ( n )**

If the type of *n* is not Number and the value of *n* is not an exact integer, throw **TypeError**.

Create and initialise a new Decimal object whose value is (*this*)<sup>*n*</sup>. The power is computed exactly.

*ZERO.pow(0)* returns *ONE*.

#### 15.13.5.34 **Decimal.prototype.precision ( )**

Return a Number containing the precision is the number of digits in the unscaled value. The precision of a zero value is 1.

#### 15.13.5.35 **Decimal.prototype.remainder ( divisor [, mc] )**

If the *divisor* is not a Decimal object, a **TypeError** exception is thrown.

If *mc* is not **undefined** and *mc* does not have a *roundingMode* property, a **TypeError** exception is thrown.

If *mc* is not **undefined** and the *roundingMode* property of the *mc* object has a value other than an integer in the range of 0 through 7, a **ValueError** exception is thrown.

The remainder is given by *this.subtract(this.divideToIntegerValue(divisor).multiply(divisor))*, with rounding according to the context settings, if not **undefined**. Note that this is not the modulo operation (the result can be negative).

#### 15.13.5.36 **Decimal.prototype.scale ( )**

Create and initialise a new Decimal object whose *this* Decimal. If zero or positive, the scale is the number of digits to the right of the decimal point. If negative, the unscaled value of the number is multiplied by ten to the power of the negation of the scale. For example, a scale of -3 means the unscaled value is multiplied by 1000.

#### 15.13.5.37 **Decimal.prototype.scaleByPowerOfTen ( n )**

If the type of *n* is not Number and the value of *n* is not an exact integer, throw a **TypeError** exception.

Create and initialise a new Decimal object whose numerical value is equal to (*this* \* 10\*\**n*). The scale of the result is (*this.scale()* - *n*).

#### 15.13.5.38 **Decimal.prototype.setScale ( newScale [, roundingMode] )**

If the type of *newScale* is not Number and the value of *n* is not an exact integer, throw a **TypeError** exception.

If *roundingMode* is not undefined and not in the range of 0 through 7, a **RangeError** exception is thrown.

Create and initialise a new Decimal object whose scale is the specified value, and whose unscaled value is determined by multiplying or dividing this Decimal's unscaled value by the appropriate power of ten to maintain its overall value. If the scale is reduced by the operation, the unscaled value must be divided (rather than multiplied), and the value may be changed; in this case, the specified rounding mode is applied to the division.

#### **15.13.5.39 Decimal.prototype.signum ()**

1. If the value of this is negative, return -1.
2. If the value of this is positive, return 1.
3. If the value of this is zero, return 0.

#### **15.13.5.40 Decimal.prototype.stripTrailingZeros ()**

Create and initialise a new Decimal object whose is numerically equal to this one but with any trailing zeros removed from the representation. For example, stripping the trailing zeros from the Decimal value 600.0, which has a scale() of 1, yields 6E2 which has a scale() of -2.

#### **15.13.5.41 Decimal.prototype.subtract ( subtrahend [, mc] )**

If the *subtrahend* is not a Decimal object, a **TypeError** exception is thrown.

If *mc* is not **undefined** and *mc* does not have a *roundingMode* property, a **TypeError** exception is thrown.

If *mc* is not undefined and the *roundingMode* property of the *mc* object has a value other than an integer in the range of 0 through 7, a **ValueError** exception is thrown.

Create and initialise a new Decimal object whose value is (this - subtrahend), with rounding according to the context settings, if not **undefined**. If *subtrahend* is zero then this, rounded if necessary, is used as the result. If this is zero then the result is subtrahend.negate(mc).

#### **15.13.5.42 Decimal.prototype.ulp ()**

Create and initialise a new Decimal object with an ulp, a unit in the last place, of this Decimal. An ulp of a nonzero Decimal value is the positive distance between this value and the Decimal value next larger in magnitude with the same number of digits. An ulp of a zero value is numerically equal to 1 with the scale of this. The result is stored with the same scale as this.

#### **15.13.5.43 Decimal.prototype.unscaledValue ()**

Create and initialise a new Decimal object whose value is the unscaled value of this Decimal. (Computes (this \* 10\*\*this.scale()).)

### **15.13.6 Properties of Decimal Instances**

Decimal instances have no special properties beyond those inherited from the Decimal prototype object.



## 16 Errors

An implementation should report runtime errors at the time the relevant language construct is evaluated. An implementation may report syntax errors in the program at the time the program is read in, or it may, at its option, defer reporting syntax errors until the relevant statement is reached. An implementation may report syntax errors in `eval` code at the time `eval` is called, or it may, at its option, defer reporting syntax errors until the relevant statement is reached.

An implementation may treat any instance of the following kinds of runtime errors as a syntax error and therefore report it early:

Improper uses of `return`, `break`, and `continue`.

Using the `eval` property other than via a direct call.

Errors in regular expression literals.

Attempts to call `PutValue` on a value that is not a reference (for example, executing the assignment statement `3=4`).

An implementation shall not report other kinds of runtime errors early even if the compiler can prove that a construct cannot execute without error under any circumstances. An implementation may issue an early warning in such a case, but it should not report the error until the relevant construct is actually executed.

An implementation shall report all errors as specified, except for the following:

An implementation may extend program and regular expression syntax. To permit this, all operations (such as calling `eval`, using a regular expression literal, or using the `Function` or `RegExp` constructor) that are allowed to throw `SyntaxError` are permitted to exhibit implementation-defined behaviour instead of throwing `SyntaxError` when they encounter an implementation-defined extension to the program or regular expression syntax.

An implementation may provide additional types, values, objects, properties, and functions beyond those described in this specification. This may cause constructs (such as looking up a variable in the global scope) to have implementation-defined behaviour instead of throwing an error (such as `ReferenceError`).

An implementation is not required to detect `EvalError`. If it chooses not to detect `EvalError`, the implementation must allow `eval` to be used indirectly and/or allow assignments to `eval`.

An implementation may define behaviour other than throwing `RangeError` for `toFixed`, `toExponential`, and `toPrecision` when the *fractionDigits* or *precision* argument is outside the specified range.

**Annex A**  
(informative)

**Grammar Summary**

**A.1 Lexical Grammar**

*SourceCharacter* ::  
any Unicode character

See clause 6

*InputElementDiv* ::  
*WhiteSpace*  
*LineTerminator*  
*Comment*  
*Token*  
*DivPunctuator*

See clause 7

pratapL 3/25/2008 1:24 AM  
**Deleted:** 6

*InputElementRegExp* ::  
*WhiteSpace*  
*LineTerminator*  
*Comment*  
*Token*  
*RegularExpressionLiteral*

See clause 7

pratapL 3/25/2008 1:24 AM  
**Deleted:** 6

*WhiteSpace* ::  
<TAB>  
<VT>  
<FF>  
<SP>  
<NEL>  
<NBSP>  
<ZWSP>  
<LS>  
<PS>  
<BOM>  
<USP>

See 7.2

*LineTerminator* ::  
<LF>  
<CR>

See 7.3

*Comment* ::  
*MultiLineComment*  
*SingleLineComment*

See 7.4

pratapL 7/4/2008 11:33 AM  
**Deleted:** <LS> ,  
<PS>

*MultiLineComment* ::  
/\* *MultiLineCommentChars*<sub>opt</sub> \*/

See 7.4

<i>MultiLineCommentChars</i> :: <i>MultiLineNotAsteriskChar MultiLineCommentChars<sub>opt</sub></i> * <i>PostAsteriskCommentChars<sub>opt</sub></i>	<i>See 7.4</i>																												
<i>PostAsteriskCommentChars</i> :: <i>MultiLineNotForwardSlashOrAsteriskChar MultiLineCommentChars<sub>opt</sub></i> * <i>PostAsteriskCommentChars<sub>opt</sub></i>	<i>See 7.4</i>																												
<i>MultiLineNotAsteriskChar</i> :: <i>SourceCharacter</i> <b>but not asterisk</b> *	<i>See 7.4</i>																												
<i>MultiLineNotForwardSlashOrAsteriskChar</i> :: <i>SourceCharacter</i> <b>but not forward-slash / or asterisk</b> *	<i>See 7.4</i>																												
<i>SingleLineComment</i> :: <i>// SingleLineCommentChars<sub>opt</sub></i>	<i>See 7.4</i>																												
<i>SingleLineCommentChars</i> :: <i>SingleLineCommentChar SingleLineCommentChars<sub>opt</sub></i>	<i>See 7.4</i>																												
<i>SingleLineCommentChar</i> :: <i>SourceCharacter</i> <b>but not LineTerminator</b>	<i>See 7.4</i>																												
<i>Token</i> :: <i>ReservedWord</i> <i>Identifier</i> <i>Punctuator</i> <i>NumericLiteral</i> <i>StringLiteral</i>	<i>See 7.5</i>																												
<i>ReservedWord</i> :: <i>Keyword</i> <i>FutureReservedWord</i> <i>NullLiteral</i> <i>BooleanLiteral</i>	<i>See 7.5.1</i>																												
<i>Keyword</i> :: <b>one of</b> <table><tr><td><b>break</b></td><td><b>else</b></td><td><b>new</b></td><td><b>var</b></td></tr><tr><td><b>case</b></td><td><b>finally</b></td><td><b>return</b></td><td><b>void</b></td></tr><tr><td><b>catch</b></td><td><b>for</b></td><td><b>switch</b></td><td><b>while</b></td></tr><tr><td><b>continue</b></td><td><b>function</b></td><td><b>this</b></td><td><b>with</b></td></tr><tr><td><b>default</b></td><td><b>if</b></td><td><b>throw</b></td><td><a href="#"><u>debugger</u></a></td></tr><tr><td><b>delete</b></td><td><b>in</b></td><td><b>try</b></td><td><a href="#"><u>const</u></a></td></tr><tr><td><b>do</b></td><td><b>instanceof</b></td><td><b>typeof</b></td><td></td></tr></table>	<b>break</b>	<b>else</b>	<b>new</b>	<b>var</b>	<b>case</b>	<b>finally</b>	<b>return</b>	<b>void</b>	<b>catch</b>	<b>for</b>	<b>switch</b>	<b>while</b>	<b>continue</b>	<b>function</b>	<b>this</b>	<b>with</b>	<b>default</b>	<b>if</b>	<b>throw</b>	<a href="#"><u>debugger</u></a>	<b>delete</b>	<b>in</b>	<b>try</b>	<a href="#"><u>const</u></a>	<b>do</b>	<b>instanceof</b>	<b>typeof</b>		<i>See 7.5.2</i>
<b>break</b>	<b>else</b>	<b>new</b>	<b>var</b>																										
<b>case</b>	<b>finally</b>	<b>return</b>	<b>void</b>																										
<b>catch</b>	<b>for</b>	<b>switch</b>	<b>while</b>																										
<b>continue</b>	<b>function</b>	<b>this</b>	<b>with</b>																										
<b>default</b>	<b>if</b>	<b>throw</b>	<a href="#"><u>debugger</u></a>																										
<b>delete</b>	<b>in</b>	<b>try</b>	<a href="#"><u>const</u></a>																										
<b>do</b>	<b>instanceof</b>	<b>typeof</b>																											
<i>FutureReservedWord</i> :: <b>one of</b> <table><tr><td><b>abstract</b></td><td><b>enum</b></td><td><b>int</b></td><td><b>short</b></td></tr><tr><td><b>boolean</b></td><td><b>export</b></td><td><b>interface</b></td><td><b>static</b></td></tr><tr><td><b>byte</b></td><td><b>extends</b></td><td><b>long</b></td><td><b>super</b></td></tr><tr><td><b>char</b></td><td><b>final</b></td><td><b>native</b></td><td><b>synchronized</b></td></tr></table>	<b>abstract</b>	<b>enum</b>	<b>int</b>	<b>short</b>	<b>boolean</b>	<b>export</b>	<b>interface</b>	<b>static</b>	<b>byte</b>	<b>extends</b>	<b>long</b>	<b>super</b>	<b>char</b>	<b>final</b>	<b>native</b>	<b>synchronized</b>	<i>See 7.5.3</i>												
<b>abstract</b>	<b>enum</b>	<b>int</b>	<b>short</b>																										
<b>boolean</b>	<b>export</b>	<b>interface</b>	<b>static</b>																										
<b>byte</b>	<b>extends</b>	<b>long</b>	<b>super</b>																										
<b>char</b>	<b>final</b>	<b>native</b>	<b>synchronized</b>																										

<b>class</b>	<b>float</b>	<b>package</b>	<b>throws</b>
<b>double</b>	<b>goto</b>	<b>private</b>	<b>transient</b>
	<b>implements</b>	<b>protected</b>	<b>volatile</b>
	<b>import</b>	<b>public</b>	

pratapL 5/29/2008 12:46 AM  
 Deleted: const

pratapL 5/29/2008 12:46 AM  
 Deleted: debugger

*Identifier* :: *IdentifierName* **but not** *ReservedWord* See 7.6

*IdentifierName* :: *IdentifierStart* See 7.6  
*IdentifierName* *IdentifierPart*

*IdentifierStart* :: *UnicodeLetter* See 7.6  
 \$  
 \ *UnicodeEscapeSequence*

*IdentifierPart* :: *IdentifierStart* See 7.6  
*UnicodeCombiningMark*  
*UnicodeDigit*  
*UnicodeConnectorPunctuation*  
*UnicodeEscapeSequence*

*UnicodeLetter* See 7.6  
 any character in the Unicode categories “Uppercase letter (Lu)”, “Lowercase letter (Ll)”, “Titlecase letter (Lt)”, “Modifier letter (Lm)”, “Other letter (Lo)”, or “Letter number (Nl)”.

*UnicodeCombiningMark* See 7.6  
 any character in the Unicode categories “Non-spacing mark (Mn)” or “Combining spacing mark (Mc)”

*UnicodeDigit* See 7.6  
 any character in the Unicode category “Decimal number (Nd)”

*UnicodeConnectorPunctuation* See 7.6  
 any character in the Unicode category “Connector punctuation (Pc)”

*UnicodeEscapeSequence* :: See 7.6  
 \u *HexDigit* *HexDigit* *HexDigit* *HexDigit*

*HexDigit* :: **one of** See 7.6  
 0 1 2 3 4 5 6 7 8 9 a b c d e f A B C D E F

*Punctuator* :: **one of** See 7.7

{	}	(	)	[	]
.	;	,	<	>	<=
>=	==	!=	===	!==	
+	-	*	%	++	--
<<	>>	>>>	&		^
!	~	&&		?	:

=	+=	--	*=	%=	<<=
>>=	>>>=	&=	=	^=	
{	}	(	)	[	]

*DivPunctuator* :: **one of**  
/ /= See 7.7

*Literal* :: See 7.8  
NullLiteral  
BooleanLiteral  
NumericLiteral  
StringLiteral

*NullLiteral* :: See 7.8.1  
null

*BooleanLiteral* :: See 7.8.2  
true  
false

*NumericLiteral* :: See 7.8.3  
DecimalLiteral  
HexIntegerLiteral

*DecimalLiteral* :: See 7.8.3  
DecimalIntegerLiteral . DecimalDigits<sub>opt</sub> ExponentPart<sub>opt</sub>  
. DecimalDigits ExponentPart<sub>opt</sub>  
DecimalIntegerLiteral ExponentPart<sub>opt</sub>

*DecimalIntegerLiteral* :: See 7.8.3  
0  
NonZeroDigit DecimalDigits<sub>opt</sub>

*DecimalDigits* :: See 7.8.3  
DecimalDigit  
DecimalDigits DecimalDigit

*DecimalDigit* :: **one of** See 7.8.3  
0 1 2 3 4 5 6 7 8 9

*ExponentIndicator* :: **one of** See 7.8.3  
e E

*SignedInteger* :: See 7.8.3  
DecimalDigits  
+ DecimalDigits  
- DecimalDigits

<i>HexIntegerLiteral</i> :: 0x HexDigit 0X HexDigit HexIntegerLiteral HexDigit	See 7.8.3
<i>StringLiteral</i> :: " DoubleStringCharacters <sub>opt</sub> " ' SingleStringCharacters <sub>opt</sub> '	See 7.8.4
<i>DoubleStringCharacters</i> :: DoubleStringCharacter DoubleStringCharacters <sub>opt</sub>	See 7.8.4
<i>SingleStringCharacters</i> :: SingleStringCharacter SingleStringCharacters <sub>opt</sub>	See 7.8.4
<i>DoubleStringCharacter</i> :: SourceCharacter <b>but not</b> double-quote " <b>or</b> backslash \ <b>or</b> LineTerminator \ EscapeSequence <a href="#">LineContinuation</a>	See 7.8.4
<i>SingleStringCharacter</i> :: SourceCharacter <b>but not</b> single-quote ' <b>or</b> backslash \ <b>or</b> LineTerminator \ EscapeSequence <a href="#">LineContinuation</a>	See 7.8.4
<a href="#">LineContinuation</a> :: <a href="#">\ LineTerminator</a>	See 7.8.4
<i>EscapeSequence</i> :: CharacterEscapeSequence 0 [lookahead ∉ DecimalDigit] HexEscapeSequence UnicodeEscapeSequence	See 7.8.4
<i>CharacterEscapeSequence</i> :: SingleEscapeCharacter NonEscapeCharacter	See 7.8.4
<i>SingleEscapeCharacter</i> :: <b>one of</b> ' " \ b f n r t v	See 7.8.4
<i>EscapeCharacter</i> :: SingleEscapeCharacter DecimalDigit x u	See 7.8.4
<i>HexEscapeSequence</i> :: x HexDigit HexDigit	See 7.8.4

*UnicodeEscapeSequence* :: See 7.8.4  
    u *HexDigit HexDigit HexDigit HexDigit*

*RegularExpressionLiteral* :: See 7.8.5  
    / *RegularExpressionBody* / *RegularExpressionFlags*

*RegularExpressionBody* :: See 7.8.5  
    *RegularExpressionFirstChar* *RegularExpressionChars*

*RegularExpressionChars* :: See 7.8.5  
    [empty]  
    *RegularExpressionChars* *RegularExpressionChar*

*RegularExpressionFirstChar* :: See 7.8.5  
    *NonTerminator* **but not \* or \ or /**  
    *BackslashSequence*

*RegularExpressionChar* :: See 7.8.5  
    *NonTerminator* **but not \ or /**  
    *BackslashSequence*

*BackslashSequence* :: See 7.8.5  
    \*NonTerminator*

*NonTerminator* :: See 7.8.5  
    *SourceCharacter* **but not LineTerminator**

*RegularExpressionFlags* :: See 7.8.5  
    [empty]  
    *RegularExpressionFlags* *IdentifierPart*

## A.2 Number Conversions

*StringNumericLiteral* ::: See 9.3.1  
    *StrWhiteSpace<sub>opt</sub>*  
    *StrWhiteSpace<sub>opt</sub>* *StrNumericLiteral* *StrWhiteSpace<sub>opt</sub>*

*StrWhiteSpace* ::: See 9.3.1  
    *StrWhiteSpaceChar* *StrWhiteSpace<sub>opt</sub>*

*StrWhiteSpaceChar* ::: See 9.3.1  
    [WhiteSpace](#)  
    [LineTerminator](#)

*StrNumericLiteral* ::: See 9.3.1  
    *StrDecimalLiteral*  
    *HexIntegerLiteral*

pratapL 7/2/2008 5:54 AM

**Deleted:** <TAB> ..  
<SP> ..  
<NBSP> ..  
<FF> ..  
<VT> ..  
<CR> ..  
<LF> ..  
<LS> ..  
<PS> ..  
<USP>

*StrDecimalLiteral* ::: See 9.3.1  
*StrUnsignedDecimalLiteral*  
+ *StrUnsignedDecimalLiteral*  
- *StrUnsignedDecimalLiteral*

*StrUnsignedDecimalLiteral* ::: See 9.3.1  
**Infinity**  
*DecimalDigits* . *DecimalDigits*<sub>opt</sub> *ExponentPart*<sub>opt</sub>  
. *DecimalDigits* *ExponentPart*<sub>opt</sub>  
*DecimalDigits* *ExponentPart*<sub>opt</sub>

*DecimalDigits* ::: See 9.3.1  
*DecimalDigit*  
*DecimalDigits* *DecimalDigit*

*DecimalDigit* ::: one of See 9.3.1  
0 1 2 3 4 5 6 7 8 9

*ExponentPart* ::: See 9.3.1  
*ExponentIndicator* *SignedInteger*

*ExponentIndicator* ::: one of See 9.3.1  
e E

*SignedInteger* ::: See 9.3.1  
*DecimalDigits*  
+ *DecimalDigits*  
- *DecimalDigits*

*HexIntegerLiteral* ::: See 9.3.1  
**0x** *HexDigit*  
**0X** *HexDigit*  
*HexIntegerLiteral* *HexDigit*

*HexDigit* ::: one of See 9.3.1  
0 1 2 3 4 5 6 7 8 9 a b c d e f A B C D E F

### A.3 Expressions

*PrimaryExpression* : See 11.1  
**this**  
*Identifier*  
*Literal*  
*ArrayLiteral*  
*ObjectLiteral*  
( *Expression* )



*ArrayLiteral* : See 11.1.4  
[ *Elision*<sub>opt</sub> ]  
[ *ElementList* ]  
[ *ElementList* , *Elision*<sub>opt</sub> ]

*ElementList* : See 11.1.4  
*Elision*<sub>opt</sub> *AssignmentExpression*  
*ElementList* , *Elision*<sub>opt</sub> *AssignmentExpression*

*Elision* : See 11.1.4  
,  
*Elision* ,

*ObjectLiteral* : See 11.1.5  
{ }  
{ *PropertyNameAndValueList* }  
{ *PropertyNameAndValueList* , }

*PropertyNameAndValueList* : See 11.1.5  
*PropertyAssignment*  
*PropertyNameAndValueList* , *PropertyAssignment*

*PropertyAssignment* : See 11.1.5  
*PropertyName* : *AssignmentExpression*  
get *PropertyName* () { *FunctionBody* }  
set *PropertyName* ( *PropertySetParameterList* ) { *FunctionBody* } ,

*PropertyName* : See 11.1.5  
*IdentifierName*  
*StringLiteral*  
*NumericLiteral*

*PropertySetParameterList* : See 11.1.5  
*Identifier* ,

*MemberExpression* : See 11.2  
*PrimaryExpression*  
*FunctionExpression*  
*MemberExpression* [ *Expression* ]  
*MemberExpression* . *IdentifierName*  
**new** *MemberExpression* *Arguments*

*NewExpression* : See 11.2  
*MemberExpression*  
**new** *NewExpression*

*CallExpression* : See 11.2  
*MemberExpression* *Arguments*  
*CallExpression* *Arguments*  
*CallExpression* [ *Expression* ]  
*CallExpression* . *IdentifierName*

pratapL 7/2/2008 2:35 PM  
Deleted: *PropertyNameAndValueList* ,  
pratapL 7/2/2008 2:35 PM  
Deleted: : *AssignmentExpression*

pratapL 7/2/2008 2:39 PM  
Deleted: .

<i>Arguments :</i> ( ) ( <i>ArgumentList</i> )	<i>See 11.2</i>
<i>ArgumentList :</i> <i>AssignmentExpression</i> <i>ArgumentList</i> , <i>AssignmentExpression</i>	<i>See 11.2</i>
<i>LeftHandSideExpression :</i> <i>NewExpression</i> <i>CallExpression</i>	<i>See 11.2</i>
<i>PostfixExpression :</i> <i>LeftHandSideExpression</i> <i>LeftHandSideExpression</i> [no <i>LineTerminator</i> here] ++ <i>LeftHandSideExpression</i> [no <i>LineTerminator</i> here] --	<i>See 11.3</i>
<i>UnaryExpression :</i> <i>PostfixExpression</i> <b>delete</b> <i>UnaryExpression</i> <b>void</b> <i>UnaryExpression</i> <b>typeof</b> <i>UnaryExpression</i> ++ <i>UnaryExpression</i> -- <i>UnaryExpression</i> + <i>UnaryExpression</i> - <i>UnaryExpression</i> ~ <i>UnaryExpression</i> ! <i>UnaryExpression</i>	<i>See 11.4</i>
<i>MultiplicativeExpression :</i> <i>UnaryExpression</i> <i>MultiplicativeExpression</i> * <i>UnaryExpression</i> <i>MultiplicativeExpression</i> / <i>UnaryExpression</i> <i>MultiplicativeExpression</i> % <i>UnaryExpression</i>	<i>See 11.5</i>
<i>AdditiveExpression :</i> <i>MultiplicativeExpression</i> <i>AdditiveExpression</i> + <i>MultiplicativeExpression</i> <i>AdditiveExpression</i> - <i>MultiplicativeExpression</i>	<i>See 11.6</i>
<i>ShiftExpression :</i> <i>AdditiveExpression</i> <i>ShiftExpression</i> << <i>AdditiveExpression</i> <i>ShiftExpression</i> >> <i>AdditiveExpression</i> <i>ShiftExpression</i> >>> <i>AdditiveExpression</i>	<i>See 11.7</i>

*RelationalExpression* : *See 11.8*  
*ShiftExpression*  
*RelationalExpression* < *ShiftExpression*  
*RelationalExpression* > *ShiftExpression*  
*RelationalExpression* <= *ShiftExpression*  
*RelationalExpression* >= *ShiftExpression*  
*RelationalExpression* **instanceof** *ShiftExpression*  
*RelationalExpression* **in** *ShiftExpression*

*RelationalExpressionNoIn* : *See 11.8*  
*ShiftExpression*  
*RelationalExpressionNoIn* < *ShiftExpression*  
*RelationalExpressionNoIn* > *ShiftExpression*  
*RelationalExpressionNoIn* <= *ShiftExpression*  
*RelationalExpressionNoIn* >= *ShiftExpression*  
*RelationalExpressionNoIn* **instanceof** *ShiftExpression*

*EqualityExpression* : *See 11.9*  
*RelationalExpression*  
*EqualityExpression* == *RelationalExpression*  
*EqualityExpression* != *RelationalExpression*  
*EqualityExpression* === *RelationalExpression*  
*EqualityExpression* !== *RelationalExpression*

*EqualityExpressionNoIn* : *See 11.9*  
*RelationalExpressionNoIn*  
*EqualityExpressionNoIn* == *RelationalExpressionNoIn*  
*EqualityExpressionNoIn* != *RelationalExpressionNoIn*  
*EqualityExpressionNoIn* === *RelationalExpressionNoIn*  
*EqualityExpressionNoIn* !== *RelationalExpressionNoIn*

*BitwiseANDExpression* : *See 11.10*  
*EqualityExpression*  
*BitwiseANDExpression* & *EqualityExpression*

*BitwiseANDExpressionNoIn* : *See 11.10*  
*EqualityExpressionNoIn*  
*BitwiseANDExpressionNoIn* & *EqualityExpressionNoIn*

*BitwiseXORExpression* : *See 11.10*  
*BitwiseANDExpression*  
*BitwiseXORExpression* ^ *BitwiseANDExpression*

*BitwiseXORExpressionNoIn* : *See 11.10*  
*BitwiseANDExpressionNoIn*  
*BitwiseXORExpressionNoIn* ^ *BitwiseANDExpressionNoIn*

*BitwiseORExpression* : *See 11.10*  
*BitwiseXORExpression*  
*BitwiseORExpression* | *BitwiseXORExpression*

<i>BitwiseORExpressionNoIn</i> :	<i>See 11.10</i>
<i>BitwiseXORExpressionNoIn</i>	
<i>BitwiseORExpressionNoIn</i>   <i>BitwiseXORExpressionNoIn</i>	
<i>LogicalANDExpression</i> :	<i>See 11.11</i>
<i>BitwiseORExpression</i>	
<i>LogicalANDExpression</i> && <i>BitwiseORExpression</i>	
<i>LogicalANDExpressionNoIn</i> :	<i>See 11.11</i>
<i>BitwiseORExpressionNoIn</i>	
<i>LogicalANDExpressionNoIn</i> && <i>BitwiseORExpressionNoIn</i>	
<i>LogicalORExpression</i> :	<i>See 11.11</i>
<i>LogicalANDExpression</i>	
<i>LogicalORExpression</i>    <i>LogicalANDExpression</i>	
<i>LogicalORExpressionNoIn</i> :	<i>See 11.11</i>
<i>LogicalANDExpressionNoIn</i>	
<i>LogicalORExpressionNoIn</i>    <i>LogicalANDExpressionNoIn</i>	
<i>ConditionalExpression</i> :	<i>See 11.12</i>
<i>LogicalORExpression</i>	
<i>LogicalORExpression</i> ? <i>AssignmentExpression</i> : <i>AssignmentExpression</i>	
<i>ConditionalExpressionNoIn</i> :	<i>See 11.12</i>
<i>LogicalORExpressionNoIn</i>	
<i>LogicalORExpressionNoIn</i> ? <i>AssignmentExpressionNoIn</i> : <i>AssignmentExpressionNoIn</i>	
<i>AssignmentExpression</i> :	<i>See 11.13</i>
<i>ConditionalExpression</i>	
<i>LeftHandSideExpression</i> <i>AssignmentOperator</i> <i>AssignmentExpression</i>	
<i>AssignmentExpressionNoIn</i> :	<i>See 11.13</i>
<i>ConditionalExpressionNoIn</i>	
<i>LeftHandSideExpression</i> <i>AssignmentOperator</i> <i>AssignmentExpressionNoIn</i>	
<i>AssignmentOperator</i> : <b>one of</b>	<i>See 11.13</i>
=    * =    / =    % =    + =    - =    << =    >> =    >>> =    & =    ^ =	=
<i>Expression</i> :	<i>See 11.14</i>
<i>AssignmentExpression</i>	
<i>Expression</i> , <i>AssignmentExpression</i>	
<i>ExpressionNoIn</i> :	<i>See 11.14</i>
<i>AssignmentExpressionNoIn</i>	
<i>ExpressionNoIn</i> , <i>AssignmentExpressionNoIn</i>	

## A.4 Statements

Statement : [See clause 12](#)

[SubStatement](#)  
[ConstantStatement](#)  
[VariableStatement](#)  
[FunctionDeclaration](#)

SubStatement : [See clause 12](#)

[Block](#)  
[EmptyStatement](#)  
[ExpressionStatement](#)  
[IfStatement](#)  
[IterationStatement](#)  
[ContinueStatement](#)  
[BreakStatement](#)  
[ReturnStatement](#)  
[WithStatement](#)  
[LabelledStatement](#)  
[SwitchStatement](#)  
[ThrowStatement](#)  
[TryStatement](#)

Block : [See 12.1](#)  
{ *StatementList*<sub>opt</sub> }

StatementList : [See 12.1](#)  
*Statement*  
*StatementList Statement*

VariableStatement : [See 12.2](#)  
**var** *VariableDeclarationList* ;

VariableDeclarationList : [See 12.2](#)  
*VariableDeclaration*  
*VariableDeclarationList , VariableDeclaration*

VariableDeclarationListNoIn : [See 12.2](#)  
*VariableDeclarationNoIn*  
*VariableDeclarationListNoIn , VariableDeclarationNoIn*

VariableDeclaration : [See 12.2](#)  
*Identifier Initialiser*<sub>opt</sub>

VariableDeclarationNoIn : [See 12.2](#)  
*Identifier InitialiserNoIn*<sub>opt</sub>

Initialiser : [See 12.2](#)  
**=** *AssignmentExpression*

InitialiserNoIn : [See 12.2](#)  
**=** *AssignmentExpressionNoIn*

pratapL 7/4/2008 11:18 AM

Deleted: VariableStatement ..

<i>EmptyStatement</i> :	<i>See 12.3</i>
;	
<i>ExpressionStatement</i> :	<i>See 12.4</i>
[lookahead $\notin$ { <b>function</b> }] <i>Expression</i> ;	
<i>IfStatement</i> :	<i>See 12.5</i>
<b>if</b> ( <i>Expression</i> ) <i>SubStatement</i> <b>else</b> <i>SubStatement</i>	
<b>if</b> ( <i>Expression</i> ) <i>SubStatement</i>	
<i>IterationStatement</i> :	<i>See 12.6</i>
<b>do</b> <i>SubStatement</i> <b>while</b> ( <i>Expression</i> ) ;	
<b>while</b> ( <i>Expression</i> ) <i>SubStatement</i>	
<b>for</b> ( <i>ExpressionNoIn</i> <sub>opt</sub> ; <i>Expression</i> <sub>opt</sub> ; <i>Expression</i> <sub>opt</sub> ) <i>SubStatement</i>	
<b>for</b> ( <b>var</b> <i>VariableDeclarationListNoIn</i> ; <i>Expression</i> <sub>opt</sub> ; <i>Expression</i> <sub>opt</sub> ) <i>SubStatement</i>	
<b>for</b> ( <i>LeftHandSideExpression in Expression</i> ) <i>SubStatement</i>	
<b>for</b> ( <b>var</b> <i>VariableDeclarationNoIn in Expression</i> ) <i>SubStatement</i>	
<i>ContinueStatement</i> :	<i>See 12.7</i>
<b>continue</b> [no <i>LineTerminator</i> here] <i>Identifier</i> <sub>opt</sub> ;	
<i>BreakStatement</i> :	<i>See 12.8</i>
<b>break</b> [no <i>LineTerminator</i> here] <i>Identifier</i> <sub>opt</sub> ;	
<i>ReturnStatement</i> :	<i>See 12.9</i>
<b>return</b> [no <i>LineTerminator</i> here] <i>Expression</i> <sub>opt</sub> ;	
<i>WithStatement</i> :	<i>See 12.10</i>
<b>with</b> ( <i>Expression</i> ) <i>SubStatement</i>	
<i>SwitchStatement</i> :	<i>See 12.11</i>
<b>switch</b> ( <i>Expression</i> ) <i>CaseBlock</i>	
<i>CaseBlock</i> :	<i>See 12.11</i>
{ <i>CaseClauses</i> <sub>opt</sub> }	
{ <i>CaseClauses</i> <sub>opt</sub> <i>DefaultClause</i> <i>CaseClauses</i> <sub>opt</sub> }	
<i>CaseClauses</i> :	<i>See 12.11</i>
<i>CaseClause</i>	
<i>CaseClauses</i> <i>CaseClause</i>	
<i>CaseClause</i> :	<i>See 12.11</i>
<b>case</b> <i>Expression</i> : <i>StatementList</i> <sub>opt</sub>	
<i>DefaultClause</i> :	<i>See 12.11</i>
<b>default</b> : <i>StatementList</i> <sub>opt</sub>	

<i>LabelledStatement</i> :	<i>See 12.12</i>
<i>Identifier</i> : <i>Statement</i>	
<i>ThrowStatement</i> :	<i>See 12.13</i>
<b>throw</b> [no <i>LineTerminator</i> here] <i>Expression</i> ;	
<i>TryStatement</i> :	<i>See 12.14</i>
<b>try</b> <i>Block</i> <i>Catch</i>	
<b>try</b> <i>Block</i> <i>Finally</i>	
<b>try</b> <i>Block</i> <i>Catch</i> <i>Finally</i>	
<i>Catch</i> :	<i>See 12.14</i>
<b>catch</b> ( <i>Identifier</i> ) <i>Block</i>	
<i>Finally</i> :	<i>See 12.14</i>
<b>finally</b> <i>Block</i>	
<u><i>ConstantStatement</i> :</u>	<u><i>Sec 12.15</i></u>
<b>const</b> <i>ConstantDeclarationList</i> ;	
<u><i>ConstantDeclarationList</i> :</u>	<u><i>Sec 12.15</i></u>
<i>ConstantDeclaration</i>	
<i>ConstantDeclarationList</i> , <i>ConstantDeclaration</i>	
<u><i>ConstantDeclaration</i> :</u>	<u><i>Sec 12.15</i></u>
<i>Identifier</i> <i>Initialiser</i>	
<b>A.5 Functions and Programs</b>	
<i>FunctionDeclaration</i> :	<i>See clause 13</i>
<b>function</b> <i>Identifier</i> ( <i>FormalParameterList</i> <sub>opt</sub> ) { <i>FunctionBody</i> }	
<i>FunctionExpression</i> :	<i>See clause 13</i>
<b>function</b> <i>Identifier</i> <sub>opt</sub> ( <i>FormalParameterList</i> <sub>opt</sub> ) { <i>FunctionBody</i> }	
<i>FormalParameterList</i> :	<i>See clause 13</i>
<i>Identifier</i>	
<i>FormalParameterList</i> , <i>Identifier</i>	
<i>FunctionBody</i> :	<i>See clause 13</i>
<i>SourceElements</i>	
<i>Program</i> :	<i>See clause 14</i>
<i>SourceElements</i>	
<i>SourceElements</i> :	<i>See clause 14</i>
<i>SourceElement</i>	
<i>SourceElements</i> <i>SourceElement</i>	

SourceElement : See clause 14  
Statement

### A.6 Universal Resource Identifier Character Classes

uri ::: See 15.1.3  
uriCharacters<sub>opt</sub>

uriCharacters ::: See 15.1.3  
uriCharacter uriCharacters<sub>opt</sub>

uriCharacter ::: See 15.1.3  
uriReserved  
uriUnescaped  
uriEscaped

uriReserved ::: one of See 15.1.3  
; / ? : @ & = + \$ ,

uriUnescaped ::: See 15.1.3  
uriAlpha  
DecimalDigit  
uriMark

uriEscaped ::: See 15.1.3  
% HexDigit HexDigit

uriAlpha ::: one of See 15.1.3  
a b c d e f g h i j k l m n o p q r s t u v w x y z  
A B C D E F G H I J K L M N O P Q R S T U V W X Y Z

uriMark ::: one of See 15.1.3  
- . ! ~ \* \ ( )

### A.7 Regular Expressions

Pattern ::: See 15.10.1  
Disjunction

Disjunction ::: See 15.10.1  
Alternative  
Alternative | Disjunction

Alternative ::: See 15.10.1  
[empty]  
Alternative Term

Term ::: See 15.10.1  
Assertion  
Atom  
Atom Quantifier

pratapL 7/3/2008 6:46 PM  
Deleted: FunctionDeclaration

pratapL 7/4/2008 11:22 AM  
Deleted: '



*Assertion* :: *See 15.10.1*  
^  
\$  
\ b  
\ B

*Quantifier* :: *See 15.10.1*  
*QuantifierPrefix*  
*QuantifierPrefix* ?

*QuantifierPrefix* :: *See 15.10.1*  
\*  
+  
?  
{ *DecimalDigits* }  
{ *DecimalDigits* , }  
{ *DecimalDigits* , *DecimalDigits* }

*Atom* :: *See 15.10.1*  
*PatternCharacter*  
.  
\ *AtomEscape*  
*CharacterClass*  
( *Disjunction* )  
( ? : *Disjunction* )  
( ? = *Disjunction* )  
( ? ! *Disjunction* )

*PatternCharacter* :: *SourceCharacter but not any of:* *See 15.10.1*  
^ \$ \ . \* + ? ( ) [ ] { } |

*AtomEscape* :: *See 15.10.1*  
*DecimalEscape*  
*CharacterEscape*  
*CharacterClassEscape*

*CharacterEscape* :: *See 15.10.1*  
*ControlEscape*  
c *ControlLetter*  
*HexEscapeSequence*  
*UnicodeEscapeSequence*  
*IdentityEscape*

*ControlEscape* :: **one of** *See 15.10.1*  
f n r t v

*ControlLetter* :: **one of** *See 15.10.1*  
a b c d e f g h i j k l m n o p q r s t u v w x y z  
A B C D E F G H I J K L M N O P Q R S T U V W X Y Z

*IdentityEscape* :: See 15.10.1  
SourceCharacter **but not** IdentifierPart

*DecimalEscape* :: See 15.10.1  
DecimalIntegerLiteral [lookahead  $\notin$  DecimalDigit]

*CharacterClass* :: See 15.10.1  
[ [lookahead  $\notin$  {^}] ClassRanges ]  
[ ^ ClassRanges ]

*ClassRanges* :: See 15.10.1  
[empty]  
NonemptyClassRanges

*NonemptyClassRanges* :: See 15.10.1  
ClassAtom  
ClassAtom NonemptyClassRangesNoDash  
ClassAtom  $\rightarrow$  ClassAtom ClassRanges

*NonemptyClassRangesNoDash* :: See 15.10.1  
ClassAtom  
ClassAtomNoDash NonemptyClassRangesNoDash  
ClassAtomNoDash  $\rightarrow$  ClassAtom ClassRanges

*ClassAtom* :: See 15.10.1  
-  
ClassAtomNoDash

*ClassAtomNoDash* :: See 15.10.1  
SourceCharacter **but not one of** \ ] -  
\ ClassEscape

*ClassEscape* :: See 15.10.1  
DecimalEscape  
**b**  
CharacterEscape  
CharacterClassEscape

pratapL 7/4/2008 11:22 AM  
Deleted: -

pratapL 7/4/2008 11:22 AM  
Deleted: -

DRAFT

04 July 2008

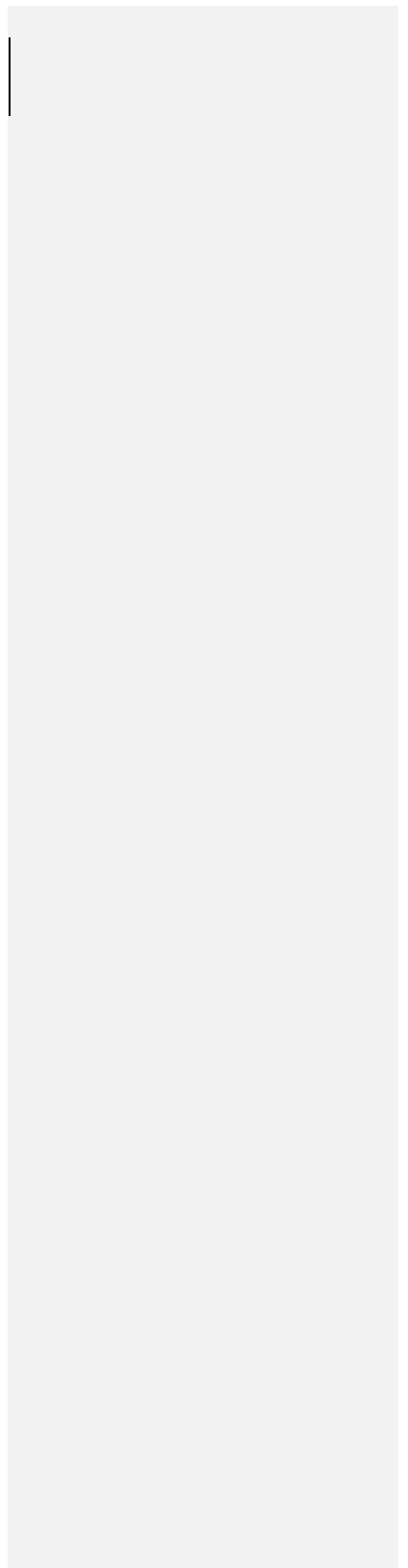

## Annex B (informative)

### Compatibility

#### B.1 Additional Syntax

Past editions of ECMAScript have included additional syntax and semantics for specifying octal literals and octal escape sequences. These have been removed from this edition of ECMAScript. This non-normative annex presents uniform syntax and semantics for octal literals and octal escape sequences for compatibility with some older ECMAScript programs.

##### B.1.1 Numeric Literals

The syntax and semantics of 7.8.3 can be extended as follows:

###### Syntax

*NumericLiteral* ::

*DecimalLiteral*  
*HexIntegerLiteral*  
*OctalIntegerLiteral*

*OctalIntegerLiteral* ::

**0** *OctalDigit*  
*OctalIntegerLiteral* *OctalDigit*

*OctalDigit* :: [one of](#)

[0 1 2 3 4 5 6 7](#)

###### Semantics

The MV of *NumericLiteral* :: *OctalIntegerLiteral* is the MV of *OctalIntegerLiteral*.

The MV of *OctalDigit* :: **0** is 0.

The MV of *OctalDigit* :: **1** is 1.

The MV of *OctalDigit* :: **2** is 2.

The MV of *OctalDigit* :: **3** is 3.

The MV of *OctalDigit* :: **4** is 4.

The MV of *OctalDigit* :: **5** is 5.

The MV of *OctalDigit* :: **6** is 6.

The MV of *OctalDigit* :: **7** is 7.

The MV of *OctalIntegerLiteral* :: **0** *OctalDigit* is the MV of *OctalDigit*.

The MV of *OctalIntegerLiteral* :: *OctalIntegerLiteral* *OctalDigit* is (the MV of *OctalIntegerLiteral* times 8) plus the MV of *OctalDigit*.

##### B.1.2 String Literals

The syntax and semantics of 7.8.4 can be extended as follows:

###### Syntax

*EscapeSequence* ::

*CharacterEscapeSequence*  
*OctalEscapeSequence*  
*HexEscapeSequence*  
*UnicodeEscapeSequence*

*OctalEscapeSequence* ::

*OctalDigit* [lookahead  $\notin$  *DecimalDigit*]  
*ZeroToThree OctalDigit* [lookahead  $\notin$  *DecimalDigit*]  
*FourToSeven OctalDigit*  
*ZeroToThree OctalDigit OctalDigit*

*ZeroToThree* :: one of  
0 1 2 3

*FourToSeven* :: one of  
4 5 6 7

#### Semantics

The CV of *EscapeSequence* :: *OctalEscapeSequence* is the CV of the *OctalEscapeSequence*.

The CV of *OctalEscapeSequence* :: *OctalDigit* [lookahead  $\notin$  *DecimalDigit*] is the character whose code point value is the MV of the *OctalDigit*.

The CV of *OctalEscapeSequence* :: *ZeroToThree OctalDigit* [lookahead  $\notin$  *DecimalDigit*] is the character whose code point value is (8 times the MV of the *ZeroToThree*) plus the MV of the *OctalDigit*.

The CV of *OctalEscapeSequence* :: *FourToSeven OctalDigit* is the character whose code point value is (8 times the MV of the *FourToSeven*) plus the MV of the *OctalDigit*.

The CV of *OctalEscapeSequence* :: *ZeroToThree OctalDigit OctalDigit* is the character whose code point value is (64 (that is,  $8^2$ ) times the MV of the *ZeroToThree*) plus (8 times the MV of the first *OctalDigit*) plus the MV of the second *OctalDigit*.

The MV of *ZeroToThree* :: 0 is 0.

The MV of *ZeroToThree* :: 1 is 1.

The MV of *ZeroToThree* :: 2 is 2.

The MV of *ZeroToThree* :: 3 is 3.

The MV of *FourToSeven* :: 4 is 4.

The MV of *FourToSeven* :: 5 is 5.

The MV of *FourToSeven* :: 6 is 6.

The MV of *FourToSeven* :: 7 is 7.

## B.2 Additional Properties

Some implementations of ECMAScript have included additional properties for some of the standard native objects. This non-normative annex suggests uniform semantics for such properties without making the properties or their semantics part of this standard.

### B.2.1 `escape` (string)

The `escape` function is a property of the global object. It computes a new version of a string value in which certain characters have been replaced by a hexadecimal escape sequence.

For those characters being replaced whose code point value is `0xFF` or less, a two-digit escape sequence of the form `%xx` is used. For those characters being replaced whose code point value is greater than `0xFF`, a four-digit escape sequence of the form `%uxxxx` is used.

When the `escape` function is called with one argument *string*, the following steps are taken:

1. Call `ToString(string)`.
2. Compute the number of characters in `Result(1)`.
3. Let *R* be the empty string.
4. Let *k* be 0.
5. If *k* equals `Result(2)`, return *R*.
6. Get the character (represented as a 16-bit unsigned integer) at position *k* within `Result(1)`.
7. If `Result(6)` is one of the 69 nonblank characters  
"ABCDEFGH IJKLMNOPQRST UVWXYZ abcdefghijklmnopqrstuvwxy z0123456789@\*\_+-. /"  
then go to step 13.

8. If Result(6), is less than 256, go to step 11.
9. Let *S* be a string containing six characters "%uwx<sup>2</sup>yz" where wxyz are four hexadecimal digits encoding the value of Result(6).
10. Go to step 14.
11. Let *S* be a string containing three characters "%xy" where xy are two hexadecimal digits encoding the value of Result(6).
12. Go to step 14.
13. Let *S* be a string containing the single character Result(6).
14. Let *R* be a new string value computed by concatenating the previous value of *R* and *S*.
15. Increase *k* by 1.
16. Go to step 5.

*NOTE*

*The encoding is partly based on the encoding described in RFC1738, but the entire encoding specified in this standard is described above without regard to the contents of RFC1738.*

### B.2.2 unescape (string)

The **unescape** function is a property of the global object. It computes a new version of a string value in which each escape sequence of the sort that might be introduced by the **escape** function is replaced with the character that it represents.

When the **unescape** function is called with one argument *string*, the following steps are taken:

1. Call ToString(*string*).
2. Compute the number of characters in Result(1).
3. Let *R* be the empty string.
4. Let *k* be 0.
5. If *k* equals Result(2), return *R*.
6. Let *c* be the character at position *k* within Result(1).
7. If *c* is not %, go to step 18.
8. If *k* is greater than Result(2)-6, go to step 14.
9. If the character at position *k*+1 within Result(1) is not u, go to step 14.
10. If the four characters at positions *k*+2, *k*+3, *k*+4, and *k*+5 within Result(1) are not all hexadecimal digits, go to step 14.
11. Let *c* be the character whose code point value is the integer represented by the four hexadecimal digits at positions *k*+2, *k*+3, *k*+4, and *k*+5 within Result(1).
12. Increase *k* by 5.
13. Go to step 18.
14. If *k* is greater than Result(2)-3, go to step 18.
15. If the two characters at positions *k*+1 and *k*+2 within Result(1) are not both hexadecimal digits, go to step 18.
16. Let *c* be the character whose code point value is the integer represented by two zeroes plus the two hexadecimal digits at positions *k*+1 and *k*+2 within Result(1).
17. Increase *k* by 2.
18. Let *R* be a new string value computed by concatenating the previous value of *R* and *c*.
19. Increase *k* by 1.
20. Go to step 5.

### B.2.3 String.prototype.substr (start, length)

The **substr** method takes two arguments, *start* and *length*, and returns a substring of the result of converting this object to a string, starting from character position *start* and running for *length* characters (or through the end of the string if *length* is **undefined**). If *start* is negative, it is treated as (*sourceLength*+*start*) where *sourceLength* is the length of the string. The result is a string value, not a String object. The following steps are taken:

1. Call ToString, giving it the **this** value as its argument.
2. Call ToInteger(*start*).
3. If *length* is **undefined**, use +∞; otherwise call ToInteger(*length*).
4. Compute the number of characters in Result(1).

5. If Result(2) is positive or zero, use Result(2); else use  $\max(\text{Result}(4)+\text{Result}(2),0)$ .
6. Compute  $\min(\max(\text{Result}(3),0), \text{Result}(4)-\text{Result}(5))$ .
7. If  $\text{Result}(6) \leq 0$ , return the empty string "".
8. Return a string containing Result(6) consecutive characters from Result(1) beginning with the character at position Result(5).

The **length** property of the **substr** method is **2**.

*NOTE*

The **substr** function is intentionally generic; it does not require that its **this** value be a *String* object. Therefore it can be transferred to other kinds of objects for use as a method.

#### **B.2.4 Date.prototype.getYear ( )**

*NOTE*

The **getFullYear** method is preferred for nearly all purposes, because it avoids the "year 2000 problem."

When the **getYear** method is called with no arguments the following steps are taken:

1. Let *t* be this time value.
2. If *t* is **NaN**, return **NaN**.
3. Return  $\text{YearFromTime}(\text{LocalTime}(t)) - 1900$ .

#### **B.2.5 Date.prototype.setYear (year)**

*NOTE*

The **setFullYear** method is preferred for nearly all purposes, because it avoids the "year 2000 problem."

When the **setYear** method is called with one argument *year* the following steps are taken:

1. Let *t* be the result of  $\text{LocalTime}(\text{this time value})$ ; but if this time value is **NaN**, let *t* be **+0**.
2. Call  $\text{ToNumber}(\text{year})$ .
3. If Result(2) is **NaN**, set the **[[PrimitiveValue]]** property of the **this** value to **NaN** and return **NaN**.
4. If Result(2) is not **NaN** and  $0 \leq \text{ToInteger}(\text{Result}(2)) \leq 99$  then Result(4) is  $\text{ToInteger}(\text{Result}(2)) + 1900$ . Otherwise, Result(4) is Result(2).
5. Compute  $\text{MakeDay}(\text{Result}(4), \text{MonthFromTime}(t), \text{DateFromTime}(t))$ .
6. Compute  $\text{UTC}(\text{MakeDate}(\text{Result}(5), \text{TimeWithinDay}(t)))$ .
7. Set the **[[PrimitiveValue]]** property of the **this** value to  $\text{TimeClip}(\text{Result}(6))$ .
8. Return the value of the **[[PrimitiveValue]]** property of the **this** value.

#### **B.2.6 Date.prototype.toGMTString ( )**

*NOTE*

The property **toUTCString** is preferred. The **toGMTString** property is provided principally for compatibility with old code. It is recommended that the **toUTCString** property be used in new ECMAScript code.

The Function object that is the initial value of **Date.prototype.toGMTString** is the same Function object that is the initial value of **Date.prototype.toUTCString**.

## Annex C

### Usage Subsets

#### C.1 The cautious Subset

##### C.1.1 Excluded Features

1. A *Program* that contains *cautious* in its set of usage subsets or is evaluated within an execution context that is subset restricted to the *cautious* subset does not perform automatic semicolon insertion. Where the above rules would insert a semicolon, instead a syntax error is detected (7.9.1.1).
2. When defined within an execution context subset restricted to the *cautious* subset, a function may not have two or more formal parameters that have the same name. An attempt to create a such a function will fail, either statically, if expressed as a *FunctionDeclaration* or *FunctionExpression*, or dynamically by throwing a *SyntaxError* exception, if expressed in a call to the *Function* constructor (10.1.3.1).
3. For functions defined within an execution subset restricted to the *cautious* subset, the activation object is only initialized with an “arguments” property if the function mentions “arguments” freely in its body (10.1.6.1).
4. For functions defined within an execution subset restricted to the *cautious* subset, an *arguments* object is only created if the function mentions “arguments” freely in its body. If a *arguments* object is created, a *callee* property is not created. The *arguments* object does not share properties with the activation object. Changing the value of a *arguments* object property does not change the value of the corresponding activation object property and vice versa (10.1.8.1).
5. If either the execution context for the eval code or the execution context in which the eval operator was executed is subset restricted to the *cautious* subset, the eval code cannot instantiate variables, functions, or constants in the lexical context of its eval operator. Instead, a new variable object is appended to the head of the calling context’s scope chain and that variable object is used for variable instantiation with the eval code (10.2.2.1).
6. If *this* is evaluated within an execution context that is subset restricted to the *cautious* subset and the *this* value is *null* or *undefined*, then the *this* expression throws a *ReferenceError* exception (11.1.1.1).
7. When a postfix increment operator occurs within an execution context that is subset restricted to the *cautious* subset, its *LeftHandSide* must not be a reference to a property with the attribute value `[[Writable]]: false` nor to a non-existent property of an object whose `[[Extensible]]` property has the value *false*. In these cases a *TypeError* exception is thrown (11.3.1.1).
8. The same restrictions as specified in 11.3.1.1 apply for the postfix decrement operator (11.3.2.1).
9. When a *delete* operator occurs within an execution context that is subset restricted to the *cautious* subset, its *UnaryExpression* is further limited to being a *MemberExpression*. In addition, if the property to be deleted is has the attribute `[[Flexible]]:false`, a *TypeError* exception is thrown (11.4.1.1).
10. The same restrictions as specified in 11.3.1.1 apply for the prefix increment operator (11.4.4.1).
11. The same restrictions as specified in 11.3.1.1 apply for the prefix decrement operator (11.4.5.1).
12. When a simple assignment occurs within an execution context that is subset restricted to the *cautious* subset, its *LeftHandSide* must not evaluate to a Reference to a property of the Global Object. If it does a *ReferenceError* exception is thrown. The *LeftHandSide* also may not be a reference to a property with the attribute value `[[Writable]]:false` nor to a non-existent property of an object whose `[[Extensible]]` property has the value *false*. In these cases a *TypeError* exception is thrown (11.13.1.1).
13. A *VariableStatement* within an execution context that is subset restricted to the *cautious* subset, may not occur as the *StatementList* of a *Block*. The occurrence of a *VariableStatement* in such a context must be treated as a syntax error (12.1.1).
- 14.
15. An execution context that is subset restricted to the *cautious* subset, may not execute a *WithStatement*. The occurrence of a *WithStatement* in such a context should be treated as a syntax error (12.10.1).
16. If an execution context that is subset restricted to the *cautious* subset uses the value of the *eval* property any way other than a direct call (that is, other than by the explicit use of its name as an



*Identifier* which is the *MemberExpression* in a *CallExpression*), or if the `eval` property is assigned to, an `EvalError` exception is thrown (15.1.2.1.1).

**C.1.2 Additional Execution Exceptions**

DRAFT

**Annex D**  
**(informative)**

**Correction and Clarifications in Edition 3.1 with Possible Compatability Impact**

Through out: The meaning of phrases such as “as if by the expression **new Array()**” are subject to misinterpretation. The specification text for all interal references and invocations of standard built-in objects and methods has been clarified by making it implicit that the intent is that the actual built-in object is to be used rather than the current dynamic value of the correspondingly name property.

11.8.2, 11.8.3,11.8.5 While ECMAScript generally uses a left to right evaluation order the specification language for the > and <= operators resulted a partial right to left order. The specification has been corrected for these operators such that it now specifies a full left to right evaluation order. However, this change of order is potentially observable if user-defined valueOf or toString methods with side-effects are invoked during the evaluation process.

15.10.6 RegExp.prototype is now a RegExp object rather than an instance of Object. The value of its [[class]] internal property which is observable using Object.prototype.toString is now “RegExp” rather than “Object”

**Annex E**  
(informative)

**Additions and Changes in Edition 3.1 which Introduce Incompatibilities with Edition 3.**

Section 7.1 Unicode format control characters are no longer stripped from ECMAScript source text before processing. Unicode BOMs (byte order marks) are treated as whitespace.

Section 7.8.5 Regular expression literals now return a unique object each time the literal is evaluated. This change is detectable by any programs test the object identity of such literal values.

Section 15: Implementations are now required to ignore extra arguments to standard built-in methods unless otherwise explicitly specified. In the 3<sup>rd</sup> Edition the handling of extra arguments were undefined and implementations were explicitly allowed to throw a **TypeError** exception.

Section 15.1.1: The value properties **NaN**, **Infinity**, and **undefined** of the Global Object have been changed to be read-only properties.

Section 15.9.4.2: Date.parse is not required to first attempt to parse its argument as an ISO format string. Programs that use this format but depended upon implementation specific behavior (including failure) may behave differently.

Allen Wirfs-Brock 7/4/2008 10:07 AM

**Comment [62]:** What is the justification for this change??

Free printed copies can be ordered from:

**ECMA**  
114 Rue du Rhône  
CH-1204 Geneva  
Switzerland

Fax: +41 22 849.60.01  
Interne.ch

Files of this Standard can be freely downloaded from our ECMA web site ([www.ecma.ch](http://www.ecma.ch)). This site gives full information on ECMA, ECMA activities, ECMA Standards and Technical Reports.

04 July 2008

**ECMA**

**114 Rue du Rhône  
CH-1204 Geneva  
Switzerland**

**See inside cover page for obtaining further soft or hard copies.**

04 July 2008

## Revision History

<a href="#">25 March 2008</a>	<a href="#">pratapL</a>	<a href="#">Added errata from Mozilla (<a href="http://www.mozilla.org/js/language/E262-3-errata.html">http://www.mozilla.org/js/language/E262-3-errata.html</a>).</a>
<a href="#">26 May 2008</a>	<a href="#">pratapL</a>	<a href="#">Updated to introduce the following: Strict mode, infrastructure for the introduction of getters/setters, and improvements to String, Date, Array, Function, and Object. Removed the notions of equating and joining.</a>
<a href="#">9 June 2008</a>	<a href="#">pratapL</a>	<a href="#">Added Array generics (§15.4.4.14 to 15.4.4.22) Added support for “abc”[0] (§8.6.2.1.2). Reverted the change to separate internal properties on functions.(§8.6.2) Changed Unicode Version to 4.0.</a>
<a href="#">11 June 2008</a>	<a href="#">pratapL</a>	<a href="#">Updated 15.9.1.15 (Date Time string format) calling out that it is not required for all the fields in the ISO date format to be present. Integrated first draft of JSON changes Applied styles uniformly for NOTES.</a>
<a href="#">14 June 2008</a>	<a href="#">pratapL</a>	<a href="#">Incorporated basic placeholders for Decimal.</a>
<a href="#">15 June 2008</a>	<a href="#">pratapL</a>	<a href="#">Incorporated updated JSON exposition.</a>
<a href="#">24 June 2008</a>	<a href="#">pratapL</a>	<a href="#">All changes related to introduction of internal <code>[[Extensible]]</code> property and updating the statics on Object: 4.3.3 – abbreviated the definition of object. 4.3.24 – added <code>□</code> clarifying note: function contains executable code 4.3.25 to 4.3.28 – added definitions for property, method, attribute, own property, inherited property 8.6.1 – changed title text to add ‘and Descriptors’. Changed first and second para to introduce clarifying text – introduced Ddesc and Pdesc formally. 8.6.2 – introduced <code>[[Extensible]]</code>, removed <code>[[Dynamic]]</code>, restored allowances for host objects, and added clarifying section text. 8.6.2.1.3 – updated to use <code>[[Extensible]]</code> 8.6.2.2 – updated to use <code>[[Extensible]]</code>; steps that said ‘throw something’ now say ‘throw TypeError’. 8.6.2.5 – step that said ‘throw something’ now says ‘throw TypeError’. 10.1.8 – property attributes for each non-negative integer arg specified. 13.2.1, 13.2.2 – updated steps to use <code>[[Extensible]]</code> 15.2.3.15 – object statics specified. 15.2.4 onwards – called out the initial value of the internal <code>[[Extensible]]</code> property.</a>
<a href="#">28 June 2008</a>	<a href="#">pratapL</a>	<a href="#">7.8.4, Annex A – introduced ‘LineContinuation’ to account for string literals with line terminators.</a>
<a href="#">29 June 2008</a>	<a href="#">pratapL</a>	<a href="#">4.2 onwards – changed Writeable to Writable 4.2.2 – removed “Strict and Non-Strict Modes” and replaced with “Language Subset Selection” (placeholder) 4.3.7 – introduced built-in constructor 4.3.24 – fixed nature of a <i>function</i> 4.3.29 – added Built-in Method 7.8.5 – minor language cleanup 8.5 – fixed reference to sections 9.5 and 9.6 8.6.1 onwards – Property Attributes: changed <code>[[Dynamic]]</code> to <code>[[Flexible]]</code>, introduced default values for the attributes, changed ‘Strict’ flag to ‘Throw’ flag, changed <code>[[SetOwnProperty]]</code> to <code>[[DefineOwnProperty]]</code>, added <code>[[ThrowablePut]]</code> 8.6.2.2 – removed ‘Strict’ flag from <code>[[Put]]</code> 8.6.2.2.1 – introduced <code>[[ThrowablePut]]</code> 8.6.2.7 to 8.6.2.10 – added new internal properties 8.10 – introduced whole new section 9.10 – introduced <code>IsCallable</code> 12.2 – introduced <code>const</code> into the grammar</a>

04 July 2008

		<a href="#">14</a> – introduced <code>UseSubsetDirective</code> into the grammar <a href="#">15.4.4</a> – fixed Array methods to use <code>[[ThrowablePut]]</code> <a href="#">15.4.5.1</a> – defined <code>[[ThrowablePut]]</code> for Arrays <a href="#">15.9.4.2, 42</a> – applied Lars’ comments regarding dates <a href="#">15.9.5.42, 43</a> – fixed reference to section <a href="#">15.9.1.15</a> <a href="#">Annex C</a> – placeholder <a href="#">Annex D</a> – placeholder
<a href="#">30 June 2008</a>	<a href="#">pratapL</a>	<a href="#">11.1.5</a> – introduced syntactic sections for getters/setters in object literals
<a href="#">1 July 2008</a>	<a href="#">pratapL</a>	Integrated Unicode changes.
<a href="#">2 July 2008</a>	<a href="#">pratapL</a>	[Integrated changes from Allen] <a href="#">7.8.5</a> : Backed out change requiring early reporting of invalid regex literals; removed additional language requiring that each such literal represent a single unique object. <a href="#">11.1.5</a> Added optional trailing comma in object initialisers <a href="#">15.10.6</a> made <code>RegExp.prototype</code> be a <code>RegExp</code> and its <code>[[class]]</code> “ <code>RegExp</code> ” <a href="#">11.8.2, 11.8.3, 11.8.5</a> Fixed evaluation order for <code>&gt;</code> and <code>&lt;=</code>
<a href="#">3 July 2008</a>	<a href="#">pratapL</a>	<a href="#">11.6.1, 11.9.3, 15.13</a> – incorporated initial edits for Decimal. Introduction of “usage subset cautious”, and all restrictions ( <a href="#">7.9.1.1, 10.1.3.1, 10.1.6.1, 10.1.8.1, 10.2.2.1, 11.3.1.1, 11.4.1.1, 11.4.5.1, 11.13.1.1, 11.13.2.1, 12.0.1, 12.6.4.1, 12.10.1, 15.1.2.1.1</a> ) <a href="#">12.15.0</a> introduced <code>ConstantStatement</code> <a href="#">15.5.3.3</a> – introduced <code>String.uniqueIdentifier</code>
<a href="#">4 July 2008</a>	<a href="#">pratapL</a>	<a href="#">7.2</a> – added <code>&lt;NEL&gt;</code> as a white space character. <a href="#">7.5.2</a> – reverted the change that made <code>eval</code> a keyword <a href="#">7.8.4</a> – allowed embedded <code>LineTerminator</code> in string literals provided they are not followed by white space. <a href="#">8</a> – introduced <code>Property Descriptor</code> and <code>Property Identifier</code> as new types. <a href="#">8.6.1</a> – introduced <code>[[Const]]</code> as a property attribute. <a href="#">8.6.2.1, 8.6.2.3, 8.6.2.9, 8.6.2.10</a> – updated the algorithms to account for <code>[[Const]]</code> . <a href="#">10.1.2, 10.1.3, 12, 12.1, 12.2, 12.5, 12.6, 12.6.1, 12.6.2, 12.6.3, 12.6.4, 12.10, 12.15</a> - introduced <code>Const</code> statements, lexical scoping of consts and function declarations, restricting declarations from use as “pseudo blocks”. <a href="#">12.0.1</a> – deleted this section and added <a href="#">12.1.1</a> instead. <a href="#">15.13.2</a> – the <code>Decimal</code> constructor can no longer be called as a function; added a clarification that it does not support the internal <code>[[Call]]</code> method. <a href="#">15.13.5.17, 15.13.5.20, 15.13.5.30, 15.13.5.31, 15.13.5.35, 15.13.5.41</a> – made <code>mc</code> an optional argument. <a href="#">15.13.5.19</a> – made <code>roundingMode</code> an optional argument. <a href="#">Annex C</a> – newly added. Added a ‘Draft’ watermark to main content section (section 4), and ‘saved date’ in the footer of the page. Regenerated TOC.